



FOR SALE

FULLY LEASED INDUSTRIAL PROPERTY

491 & 655 WEST WATER STREET, TAUNTON, MA 02780



**Kelleher
& Sadowsky**

Voted Best Commercial Real Estate Brokerage - Worcester Business Journal

DONALD MANCINI, SIOR

Principal

mancini@kelleher-sadowsky.com

O: 508.635.6786

C: 774.696.8023

JIM EGAN

Vice President

egan@kelleher-sadowsky.com

O: 508.635.6793

C: 508.340.9298

EXECUTIVE SUMMARY

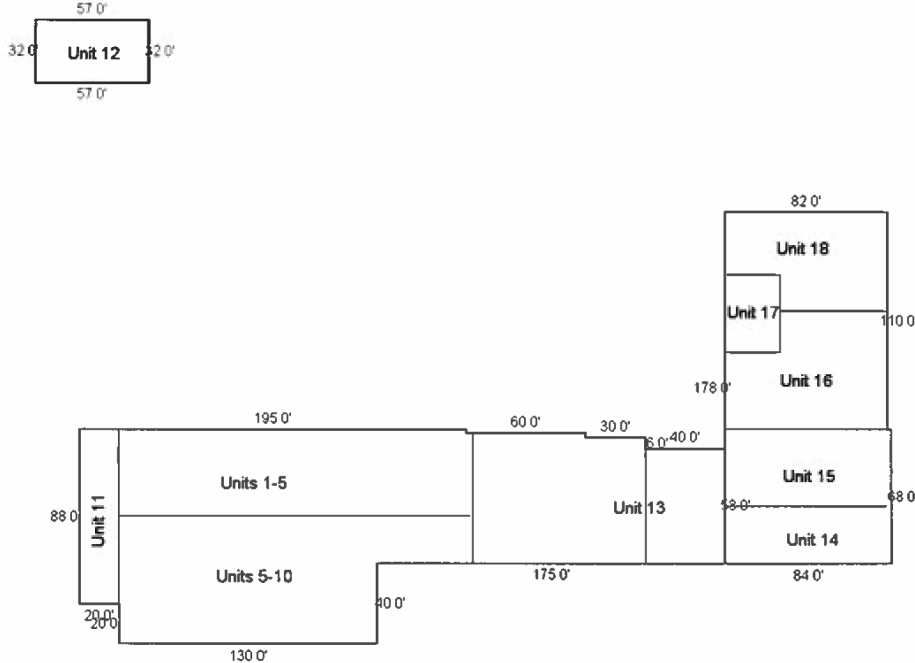

OFFERING SUMMARY

Property Type:	Industrial
Building Size:	43,830 SF
Lot Size:	7.43 Acres
Zoning:	Industrial
RE Taxes:	\$34.70
Sale Price:	\$1,200,000

PROPERTY OVERVIEW

491 West Water Street includes ±43,830 SF of 1-story warehouse space on ±7.43 acres. Ideal for a scrap yard, recycling center, repair shop, storage facility and other industrial uses. Key features include 13 truck doors, 6' thick concrete floors, significant outside space, 15' to 16' ceiling height, private office, and much more. Property is currently 100% occupied and subdivided and leased on a month-to-month basis to a variety of tenants. Perfect for an investor or user in need of industrial property for their business. ±7.24 acres of adjacent land at 655 West Water St. is separately available for sale. Please call today for a tour!

DEMOGRAPHICS

	1 MILE	3 MILES	5 MILES
Total Households	2,404	18,394	28,556
Total Population	5,958	44,795	73,092
Average HH Income	\$55,999	\$56,410	\$65,753

DONALD MANCINI, SIOR

Principal
 mancini@kelleher-sadowsky.com
 O: 508.635.6786
 C: 774.696.8023

JIM EGAN

Vice President
 egan@kelleher-sadowsky.com
 O: 508.635.6793
 C: 508.340.9298



Voted Best Commercial Real Estate Brokerage - Worcester Business Journal

120 Front Street, Suite 210 | Worcester, MA 01608 | 508.755.0707 | kelleher-sadowsky.com

ADDITIONAL PHOTOS

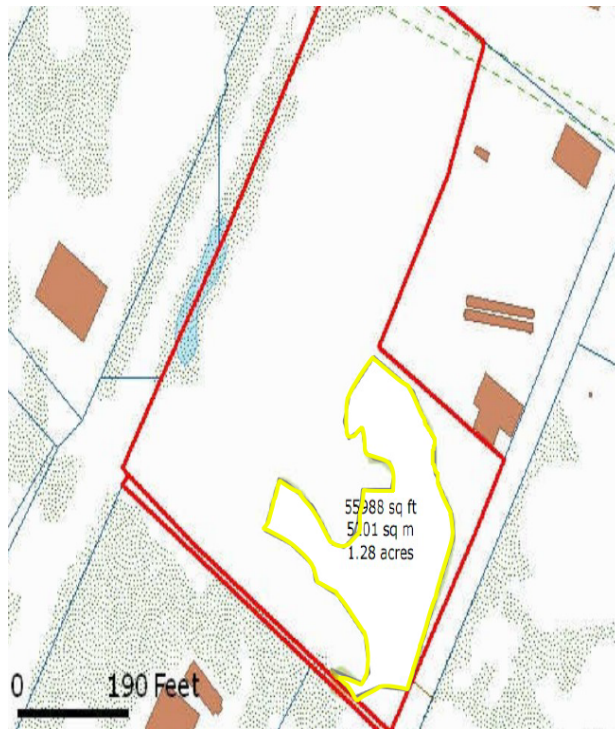
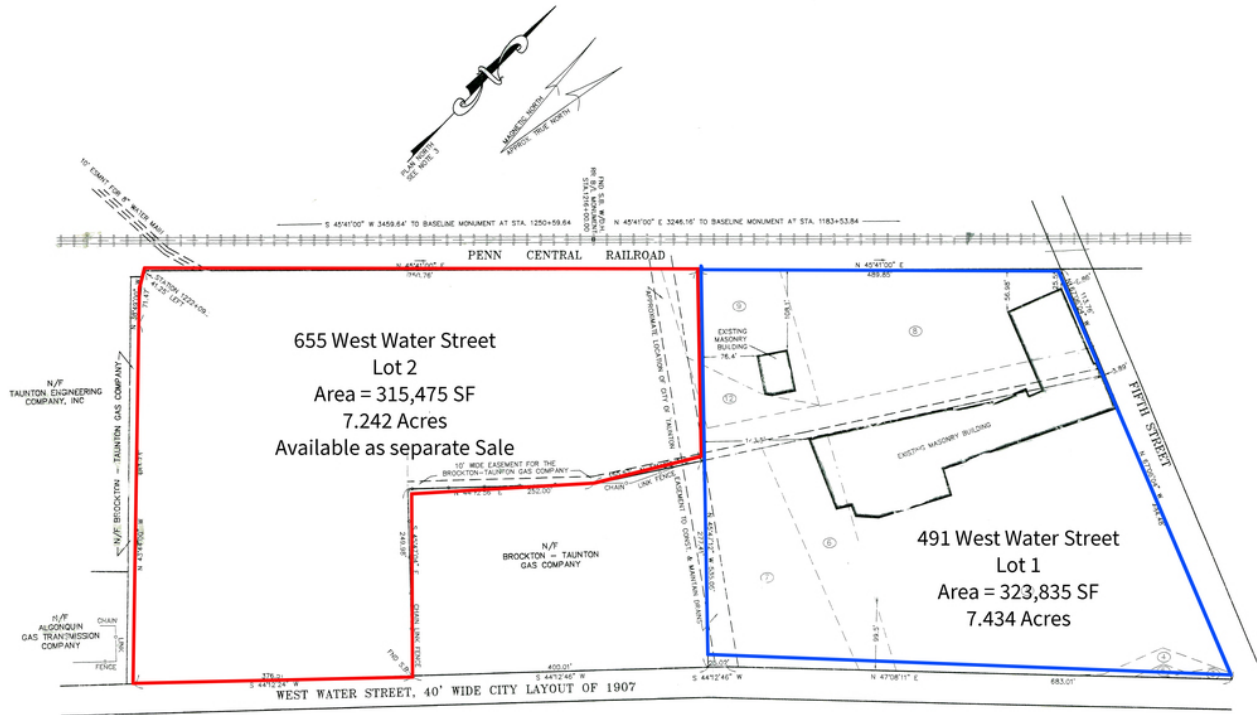

DONALD MANGINI, SIOR

Principal

mancini@kelleher-sadowsky.com
 O: 508.635.6786
 C: 774.696.8023

JIM EGAN

Vice President

egan@kelleher-sadowsky.com
 O: 508.635.6793
 C: 508.340.9298



Voted Best Commercial Real Estate Brokerage - Worcester Business Journal

120 Front Street, Suite 210 | Worcester, MA 01608 | 508.755.0707 | kelleher-sadowsky.com

ADDITIONAL PHOTOS



DONALD MANCINI, SIOR

Principal

mancini@kelleher-sadowsky.com

O: 508.635.6786

C: 774.696.8023

JIM EGAN

Vice President

egan@kelleher-sadowsky.com

O: 508.635.6793

C: 508.340.9298



**Kelleher
& Sadowsky**

Rated Best Commercial Real Estate Brokerage - Worcester Business Journal

120 Front Street, Suite 210 | Worcester, MA 01608 | 508.755.0707 | kelleher-sadowsky.com