

736 COUNTRY CLUB DR MESA, AZ 85201

11,417 SF Office Building For Sale/Lease
\$1,350,000 (\$118/SF)



Features

- Lease & Purchase Options
- 3 Suites Available For Lease
- Near Downtown Mesa
- Frontage on Country Club Dr

Ste 101 2,460 SF / \$12 MG
Ste 103 2,619 SF / \$12 MG
Ste 202 2,304 SF / \$12 MG
Total Sale Price: \$1,350,000



POPULATION
1 Mi: 24,339
3 Mi: 172,250
5 Mi: 358,023



HOUSEHOLDS
1 Mi: 10,049
3 Mi: 63,095
5 Mi: 135,310



HOUSEHOLD INCOME
1 Mi: \$35,636
3 Mi: \$38,916
5 Mi: \$44,641

Rex Griswold
M 480.244.7222
rgriswold@cpiaz.com

Andy Jaffe
D 480.214.1132
M 602.330.8777
ajaffe@cpiaz.com



COMMERCIAL PROPERTIES INC.

Locally Owned. Globally Connected. 

TEMPE: 2323 W. University Drive, Tempe, AZ 85281 | 480.966.2301
SCOTTSDALE: 8777 N. Gainey Center Dr., Suite 245, Scottsdale, AZ 85258 | www.cpiaz.com



The information contained herein has been obtained from various sources. We have no reason to doubt its accuracy; however, J & J Commercial Properties, Inc. has not verified such information and makes no guarantee, warranty or representation about such information. The prospective buyer or lessee should independently verify all dimensions, specifications, floor plans, and all information prior to the lease or purchase of the property. All offerings are subject to prior sale, lease, or withdrawal from the market without prior notice. Effective 01/06/20

736 COUNTRY CLUB DR MESA, AZ 85201



SUITE 101

- ±2,460 SF
- Reception
- 5 Offices
- Conference Room
- Break Room
- 2 Restrooms



SUITE 103

- ±2,619 SF
- Reception
- 12 Offices
- Conference Room
- 4 Exam Rooms
- 2 Restrooms



SUITE 202

- ±2,304 SF
- 1 Office
- Conference Room
- Break Room
- Bullpen
- 2 Restrooms



Rex Griswold
M 480.244.7222
rgriswold@cpi.az.com

Andy Jaffe
D 480.214.1132
M 602.330.8777
ajaffe@cpi.az.com



COMMERCIAL PROPERTIES INC.

Locally Owned. Globally Connected. CPI

TEMPE: 2323 W. University Drive, Tempe, AZ 85281 | 480.966.2301
SCOTTSDALE: 8777 N. Gainey Center Dr., Suite 245, Scottsdale, AZ 85258 | www.cpi.az.com

736

COUNTRY CLUB DR
MESA, AZ 85201

SUITE 101 - ±2,460 RSF

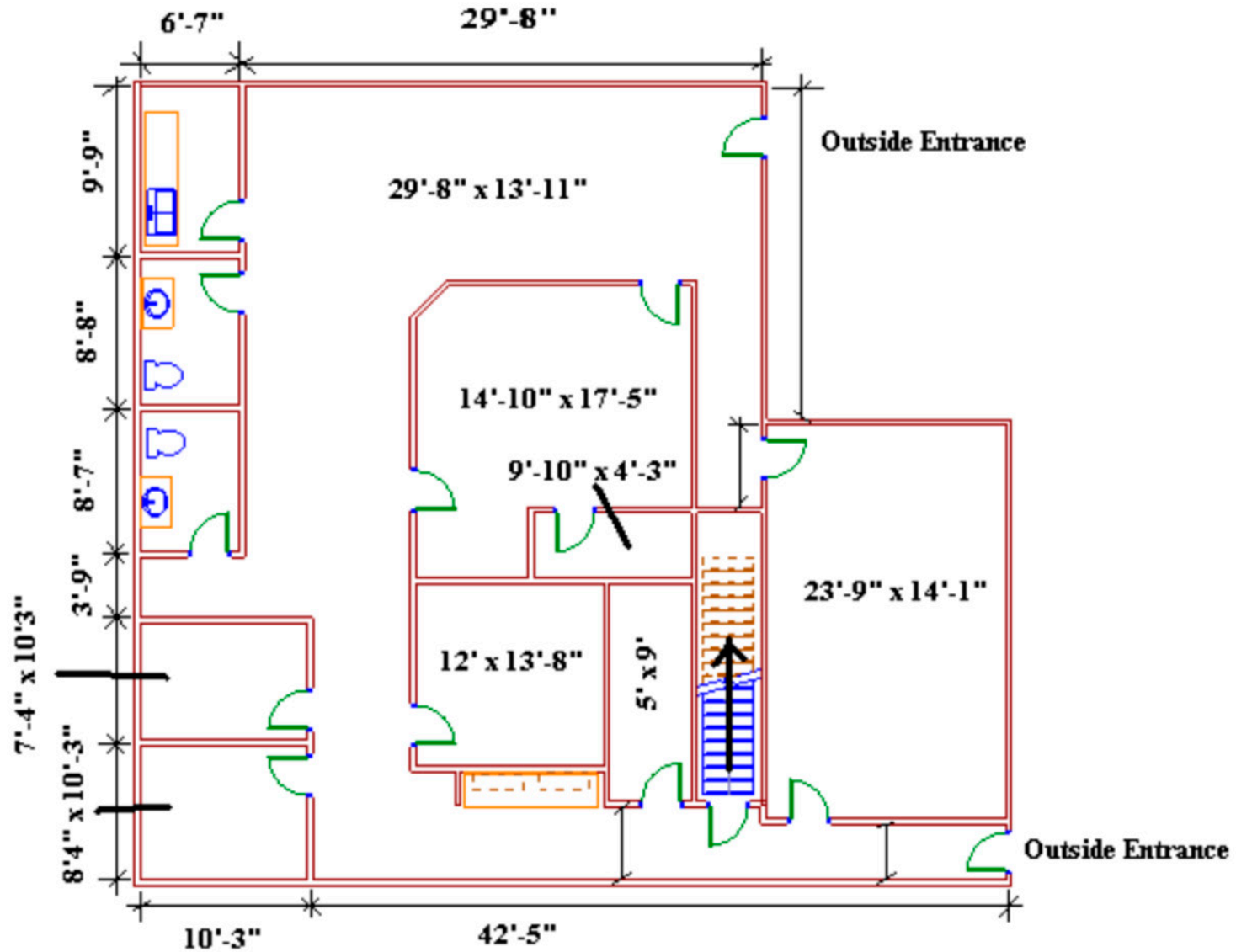

Rex Griswold
M 480.244.7222
rgriswold@cpi.az.com

Andy Jaffe
D 480.214.1132
M 602.330.8777
ajaffe@cpi.az.com



COMMERCIAL PROPERTIES INC.

Locally Owned. Globally Connected. CFPAC International

TEMPE: 2323 W. University Drive, Tempe, AZ 85281 | 480.966.2301
SCOTTSDALE: 8777 N. Gainey Center Dr., Suite 245, Scottsdale, AZ 85258 | www.cpi.az.com

736

COUNTRY CLUB DR
MESA, AZ 85201

SUITE 102 - LEASED

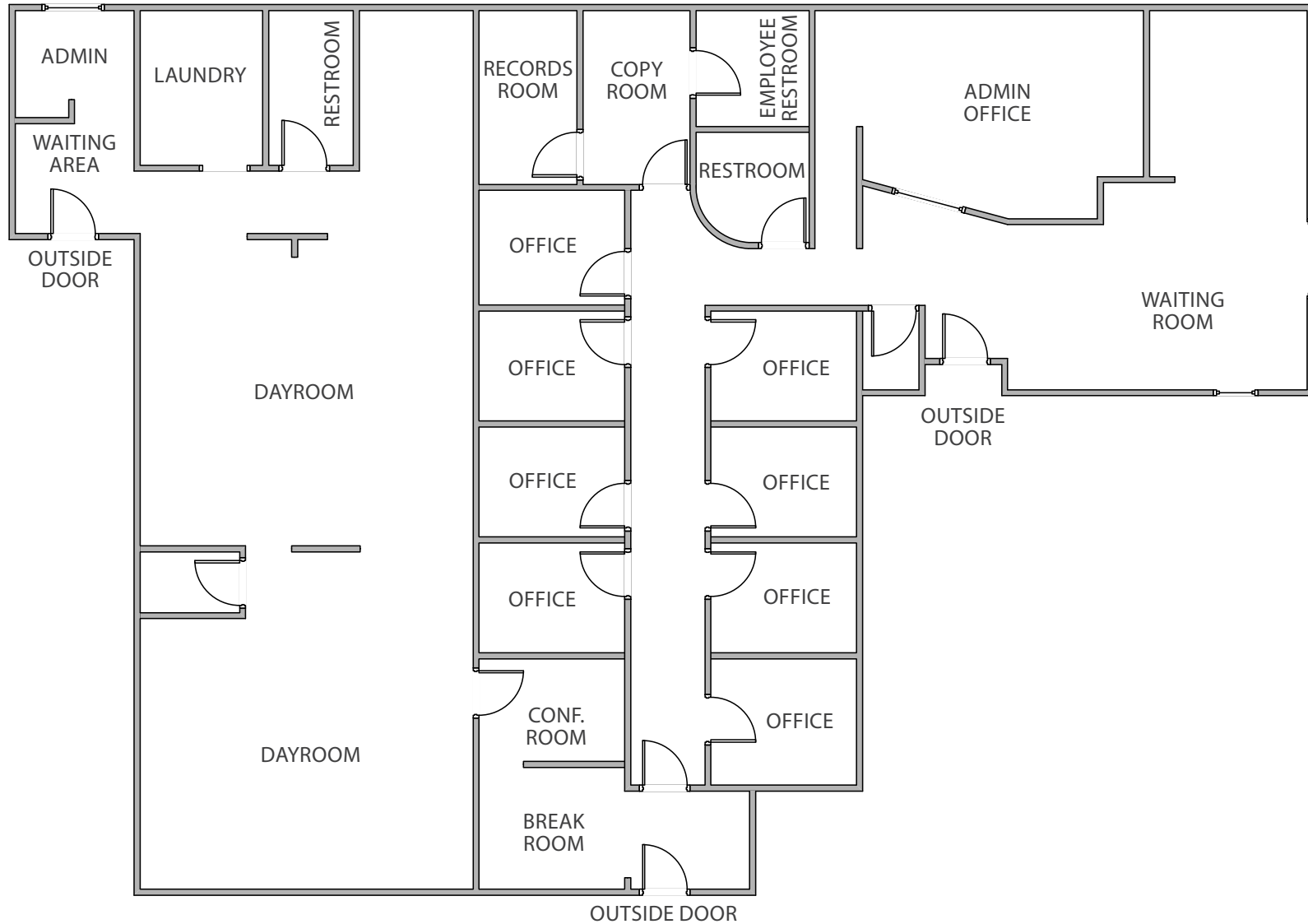

Rex Griswold
M 480.244.7222
rgriswold@cpiaz.com

Andy Jaffe
D 480.214.1132
M 602.330.8777
ajaffe@cpiaz.com



COMMERCIAL PROPERTIES INC.

Locally Owned. Globally Connected. CPPIAC International

TEMPE: 2323 W. University Drive, Tempe, AZ 85281 | 480.966.2301
SCOTTSDALE: 8777 N. Gainey Center Dr., Suite 245, Scottsdale, AZ 85258 | www.cpiaz.com

736

COUNTRY CLUB DR
MESA, AZ 85201

SUITE 103 - ±2,619 RSF

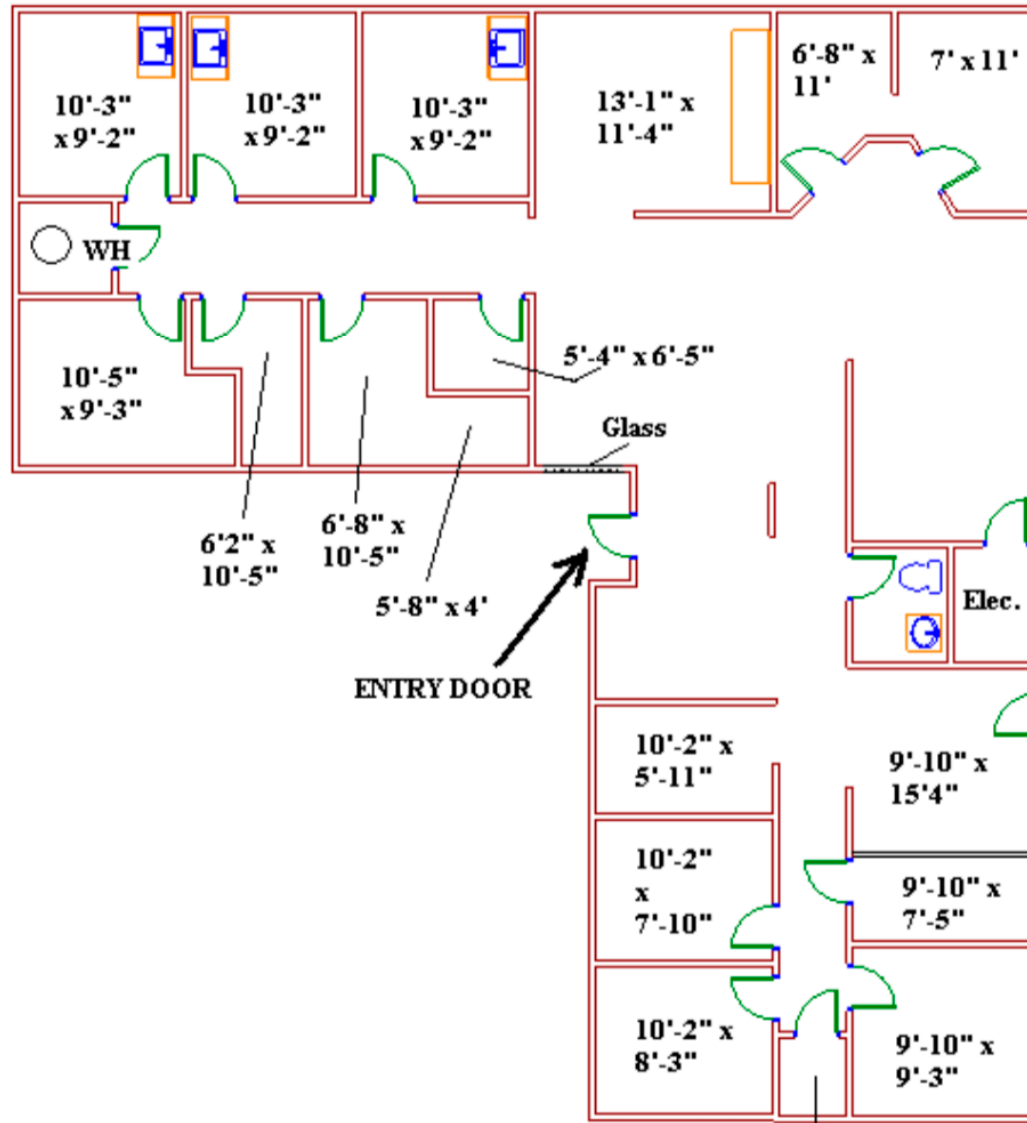

Rex Griswold
M 480.244.7222
rgriswold@cpi.az.com

Andy Jaffe
D 480.214.1132
M 602.330.8777
ajaffe@cpi.az.com



COMMERCIAL PROPERTIES INC.

Locally Owned. Globally Connected. CPIC

TEMPE: 2323 W. University Drive, Tempe, AZ 85281 | 480.966.2301
SCOTTSDALE: 8777 N. Gainey Center Dr., Suite 245, Scottsdale, AZ 85258 | www.cpi.az.com

736

COUNTRY CLUB DR
MESA, AZ 85201

SUITE 202 - ±2,304 RSF

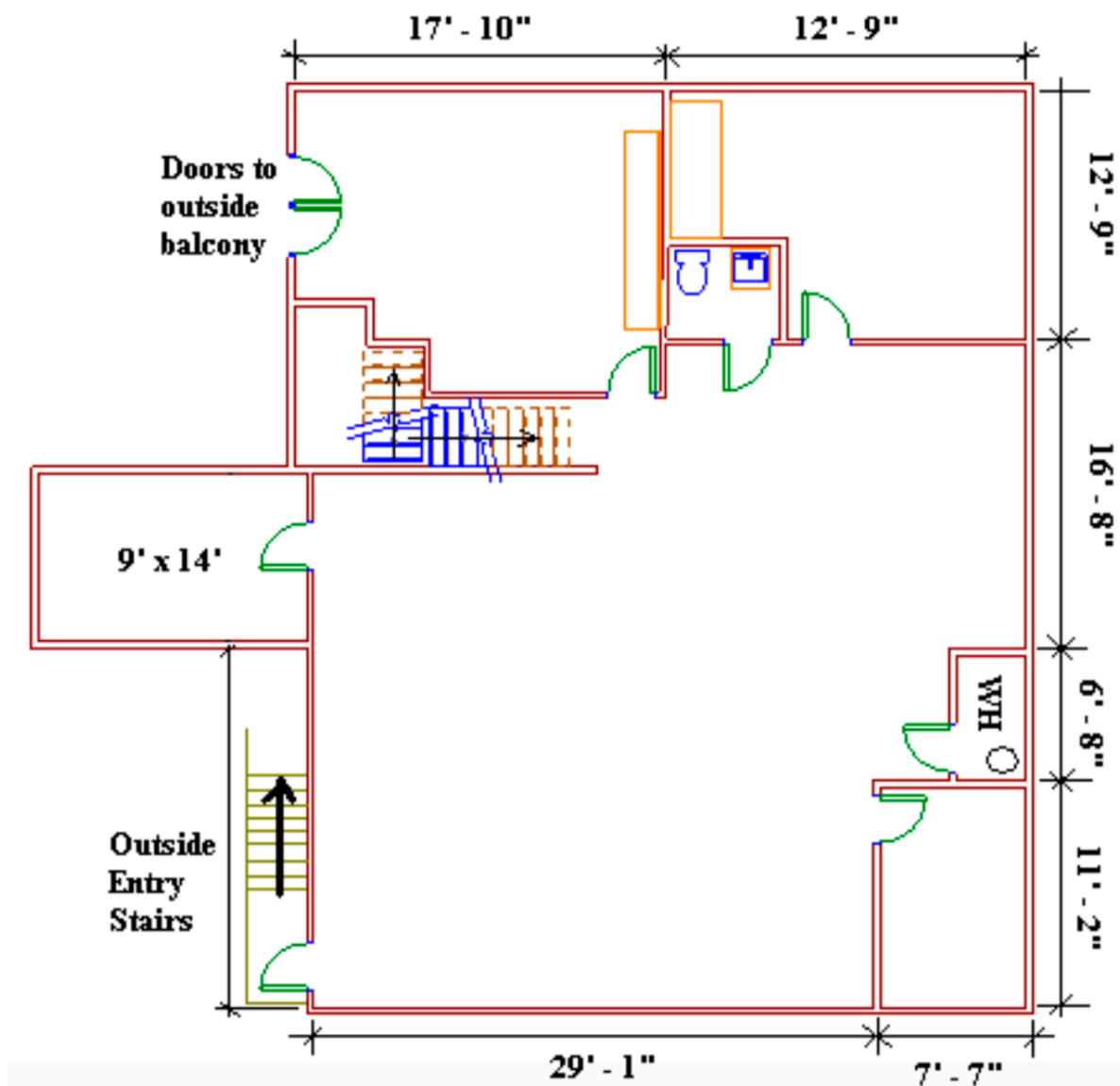

Rex Griswold
M 480.244.7222
rgriswold@cpiaz.com

Andy Jaffe
D 480.214.1132
M 602.330.8777
ajaffe@cpiaz.com



COMMERCIAL PROPERTIES INC.

Locally Owned. Globally Connected. CPPIAC International

TEMPE: 2323 W. University Drive, Tempe, AZ 85281 | 480.966.2301
SCOTTSDALE: 8777 N. Gainey Center Dr., Suite 245, Scottsdale, AZ 85258 | www.cpiaz.com