

FOR SALE OR LEASE

# OFFICE BUILDING

IN THE HEART OF  
BALLARD



# BUILDING FOR SALE OR LEASE

5135 BALLARD AVENUE NORTHWEST

SEATTLE, WA 98107

PRICE: \$2.63 MILLION

LEASE: \$24.00 PER SF, NNN

BUILDING SIZE: 3,420 SF PER KCR

## BALLARD REPUBLIK



## DETAILS

Constructed in 1896, this distinctive two-story brick masonry building is one of the oldest, architecturally intact historic buildings in the Ballard Avenue Landmark District. It was designed to house two ground floor retail shops with separate living quarters on the second floor.

In 1904, it became Ballard Livery & Transfer, a moving and storage company, and in 1982, it became the professional offices of Lagerquist & Morris Architects. The architects meticulously renovated the interior and exterior resulting in one of the most beautiful and unique buildings in Ballard. The restoration also included a complete earthquake retrofit.

Ideal office building for an owner/user.

### Contact Information

Ryan Kadletz, Founder & Designated Broker  
206.650.0883  
[ryan@montlakepartners.com](mailto:ryan@montlakepartners.com)

**MONTLAKE PARTNERS**  
COMMERCIAL REAL ESTATE

# BUILDING FOR SALE OR LEASE

5135 BALLARD AVENUE NORTHWEST

SEATTLE, WA 98107

PRICE: \$2.63 MILLION

LEASE: \$24.00 PER SF, NNN

BUILDING SIZE: 3,420 SF PER KCR

## FLOORPLANS

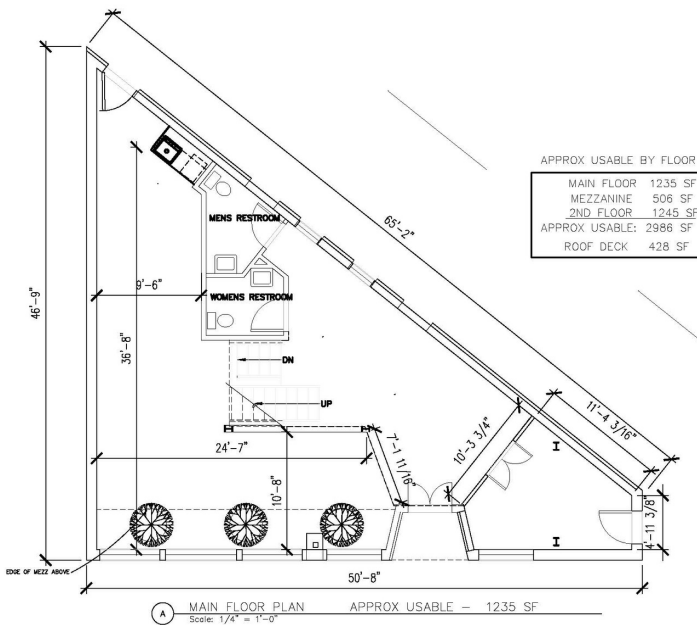

### Contact Information

Ryan Kadletz, Founder & Designated Broker

206.650.0883

ryan@montlakepartners.com

**MONTLAKE PARTNERS**  
COMMERCIAL REAL ESTATE

The information contained herein has been obtained from sources deemed reliable but is not guaranteed.

WWW.MONTLAKEPARTNERS.COM

# BUILDING FOR SALE OR LEASE

5135 BALLARD AVENUE NORTHWEST

SEATTLE, WA 98107

PRICE: \$2.63 MILLION

LEASE: \$24.00 PER SF, NNN

BUILDING SIZE: 3,420 SF PER KCR

## FLOORPLANS

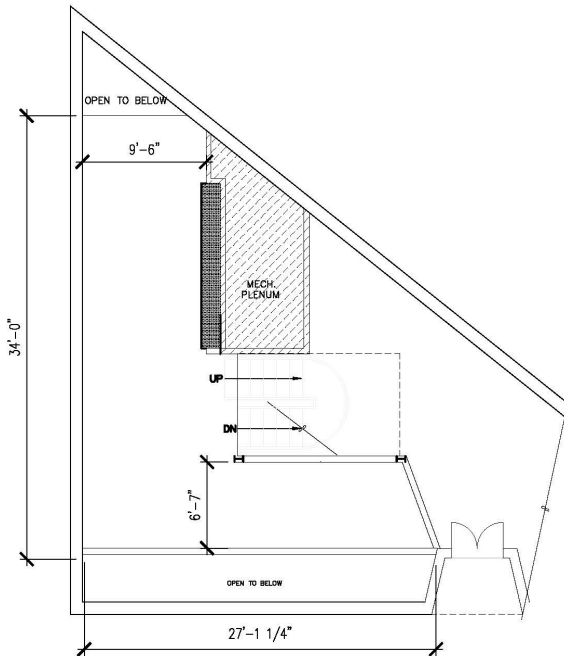

Ⓒ MEZZANINE PLAN — APPROX USABLE: 506 SF  
Scale: 1/4" = 1'-0"

### Contact Information

Ryan Kadletz, Founder & Designated Broker

206.650.0883

ryan@montlakepartners.com

**MONTLAKE PARTNERS**  
COMMERCIAL REAL ESTATE

The information contained herein has been obtained from sources deemed reliable but is not guaranteed.

WWW.MONTLAKEPARTNERS.COM

# BUILDING FOR SALE OR LEASE

5135 BALLARD AVENUE NORTHWEST

SEATTLE, WA 98107

PRICE: \$2.63 MILLION

LEASE: \$24.00 PER SF, NNN

BUILDING SIZE: 3,420 SF PER KCR

## FLOORPLANS

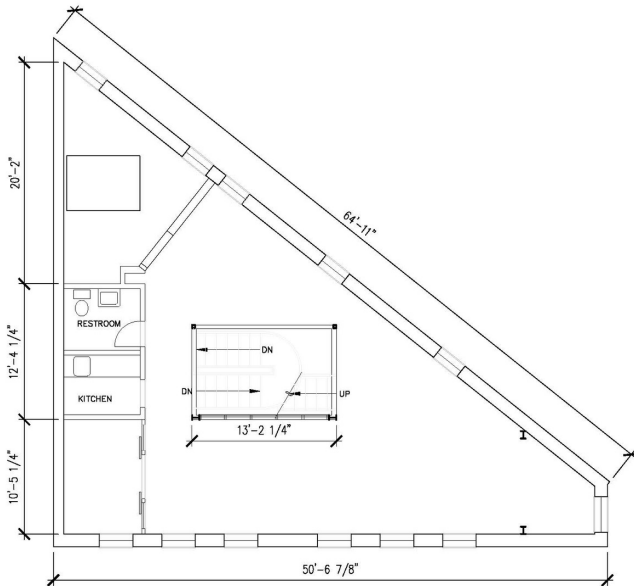

(B) UPPER FLOOR PLAN — APPROX USABLE: 1245 SF  
Scale: 1/4" = 1'-0"

### Contact Information

Ryan Kadletz, Founder & Designated Broker

206.650.0883

ryan@montlakepartners.com

**MONTLAKE PARTNERS**  
COMMERCIAL REAL ESTATE

The information contained herein has been obtained from sources deemed reliable but is not guaranteed.

# BUILDING FOR SALE OR LEASE

5135 BALLARD AVENUE NORTHWEST

SEATTLE, WA 98107

PRICE: \$2.63 MILLION

LEASE: \$24.00 PER SF, NNN

BUILDING SIZE: 3,420 SF PER KCR

## FLOORPLANS

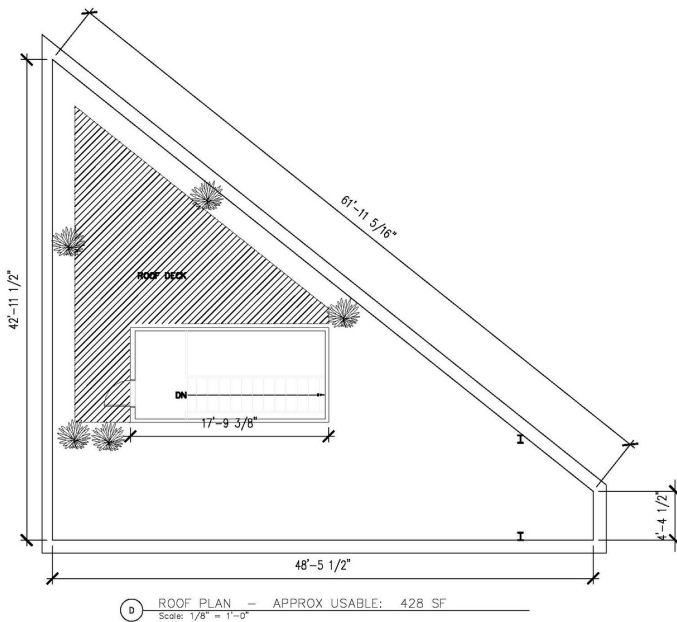

### Contact Information

Ryan Kadletz, Founder & Designated Broker

206.650.0883

[ryan@montlakepartners.com](mailto:ryan@montlakepartners.com)

**MONTLAKE PARTNERS**  
COMMERCIAL REAL ESTATE

The information contained herein has been obtained from sources deemed reliable but is not guaranteed.