

AVON MARKETPLACE

380 WEST MAIN STREET, AVON, CT



Join New Tenants:

Club Pilates, Athleta, and It's Playtime



| USE | SIZE | RENT | AVAILABLE |
|----------|----------|-----------------|---------------|
| RETAIL A | 2,560 SF | \$35.00 PSF NNN | FEBRUARY 2020 |
| RETAIL B | 2,535 SF | \$35.00 PSF NNN | MARCH 2020 |

DESCRIPTION: Highly visible retail opportunities for lease in Avon Marketplace, a vibrant and long-established lifestyle center located in the affluent Hartford suburbs of Avon/Simsbury. Co tenants include The Gap, Victoria's Secret, New Balance, Ulta Beauty, Munson's, Starbucks and more. Great exposure on busy Route 44.

CONTACT:

Sharon Maddern
203.341.7491 | sharon@davidadamrealty.com

David Waldman
203.341.7490 | david@davidadamrealty.com



57 Wilton Road, Westport, CT 06880 | Phone 203.221.8148 | Fax 203.341.7494 | www.davidadamrealty.com

The information above has been obtained from sources believed to be reliable. While we do not doubt it's accuracy, we have not verified it and make no guarantee, warranty or representation about it. It is your responsibility to independently confirm its accuracy and completeness.

AVON MARKETPLACE

380 WEST MAIN STREET, AVON, CT

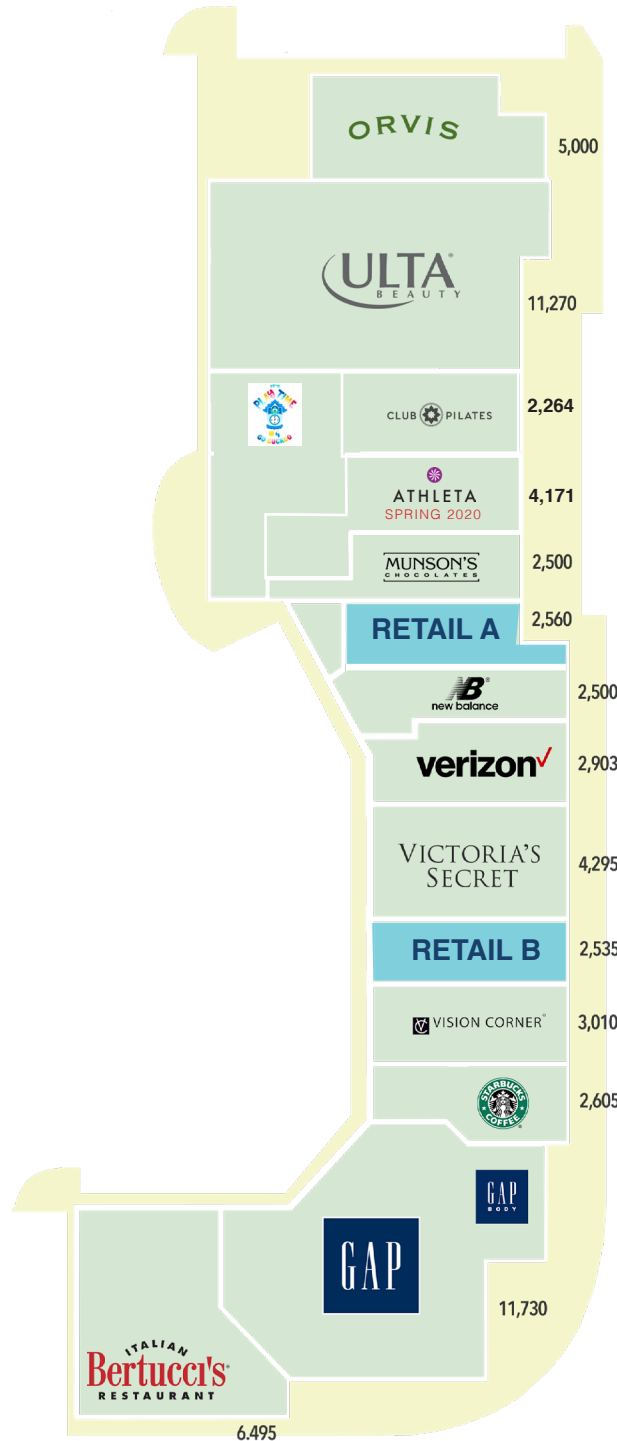

↑ **ADDITIONAL STORES**
CVS Pharmacy

↓ **ADDITIONAL STORES**
Petvalu, Relax The Back,
European Wax Center
& BurgerFi

57 Wilton Road, Westport, CT 06880 | Phone 203.221.8148 | Fax 203.341.7494 | www.davidadamrealty.com

The information above has been obtained from sources believed to be reliable. While we do not doubt it's accuracy, we have not verified it and make no guarantee, warranty or representation about it. It is your responsibility to independently confirm its accuracy and completeness.

AVON MARKETPLACE

380 WEST MAIN STREET, AVON, CT



RETAIL A

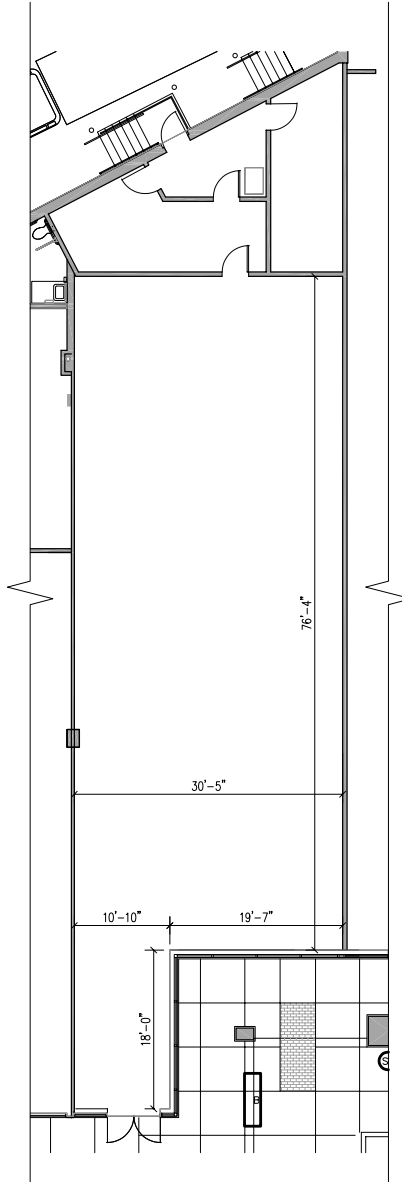

AVON MARKETPLACE

380 WEST MAIN STREET, AVON, CT



RETAIL B

