



**KEARNY
POINT**

FLEX SPACE FLOOR PLANS

SUMMER 2020

This a sample of offerings currently available and gets adjusted somewhat frequently; for more information on additional spaces, please fill out a contact form on the website or call the number below, thank you!

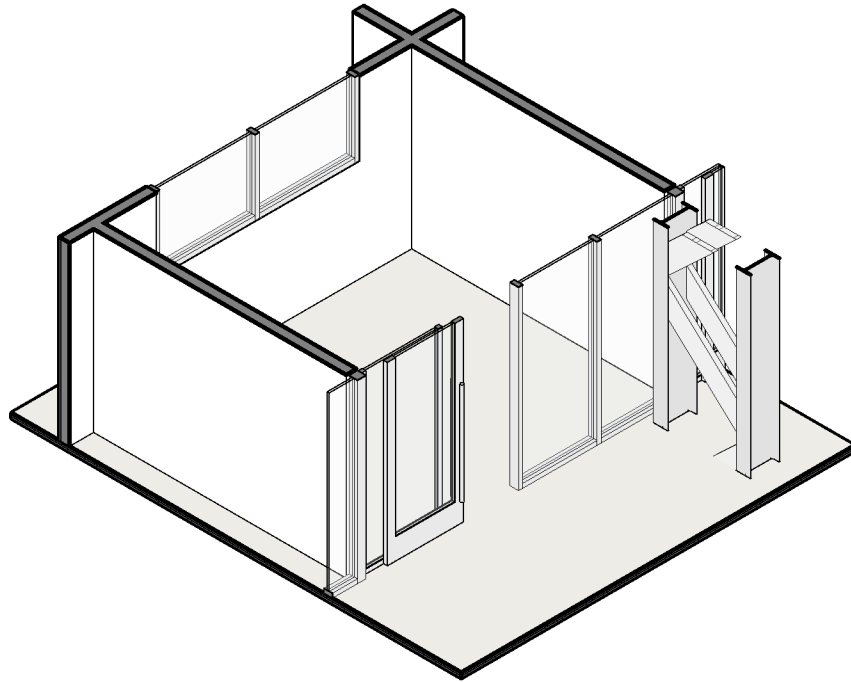
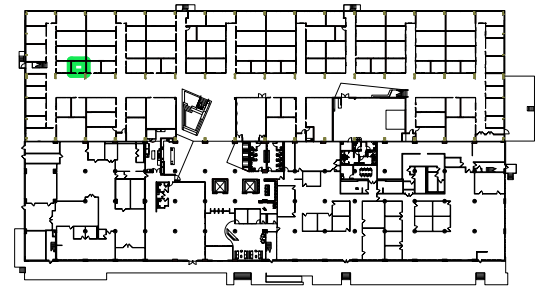

SUITE A #1023

- Ground floor unit
- \$865 / mo. unfurnished for 12 month term
- furnished/ month-to-month options available
- Includes all expenses except electricity (sub-metered), in-suite janitorial, and commercial liability insurance

UNIT 1023
132 USF / 198 RSF

BUILDING 78

78 John Miller Way, Kearny, NJ 07032

Date: 12/30/2019 Scale: N.T.S.

LEASE PLAN

UNIT 1023 AXON

LP-L1 1023.1

KEARNY POINT

HUGO NEU REALTY MANAGEMENT LLC

LEASING: 973-968-5955

STUDIOS
architecture

588 BROADWAY, SUITE 702-NEW YORK, NY 10012-212 431 4512

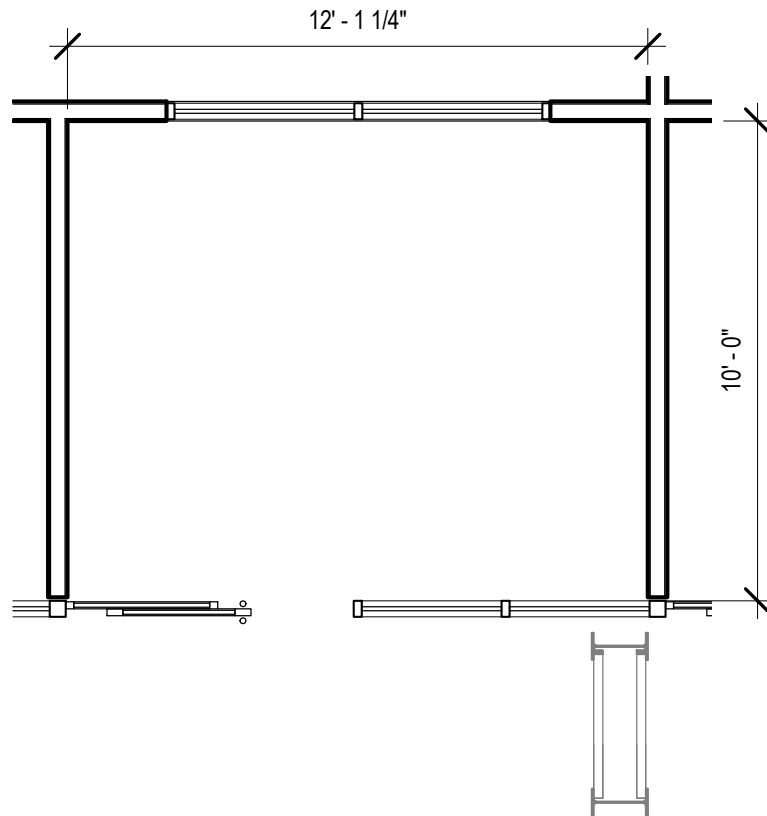
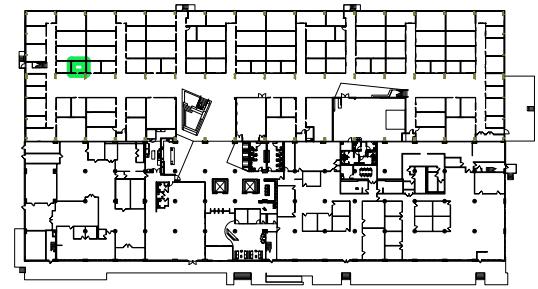

SUITE A #1023

- Ground floor unit
- \$865 / mo. unfurnished for 12 month term
- furnished/ month-to-month options available
- Includes all expenses except electricity (sub-metered), in-suite janitorial, and commercial liability insurance

UNIT 1023
132 USF / 198 RSF

BUILDING 78

78 John Miller Way, Kearny, NJ 07032

Date: 12/30/2019 Scale: N.T.S.

LEASE PLAN

UNIT 1023 PLAN

LP-L1 1023

KEARNY POINT

HUGO NEU REALTY MANAGEMENT LLC

LEASING: 973-968-5955

STUDIOS
architecture

588 BROADWAY, SUITE 702-NEW YORK, NY 10012-212 431 4512

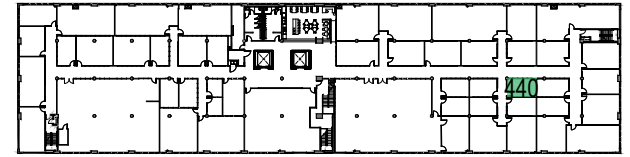

Key Plan

North Arrow

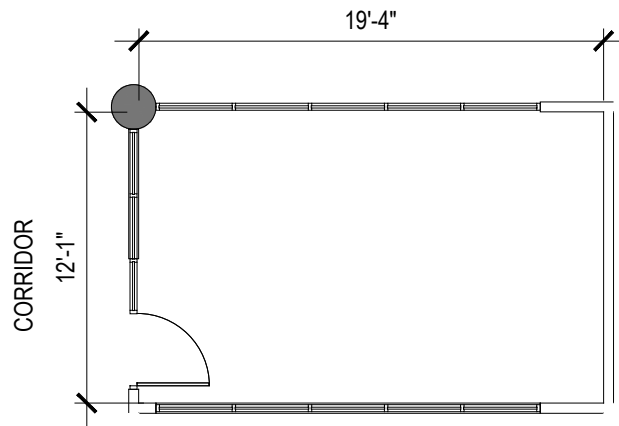

SUITE A #440

- \$950 / mo. unfurnished for 12 month term
- furnished/month-to-month options available
- Additional expenses include HVAC, internet/ phone services, electricity (sub-metered), and commercial liability insurance.

Fourth Floor - Suite 440
235 SF Net / 339 SF Gross

BUILDING 78 | 78 JOHN MILLER WAY | KEARNY, NJ 07032

LEASING DEPT.
HUGO NEU REALTY MANAGEMENT LLC
(973) 968-5955
www.kearnypoint.com



Drawing:
LP-440

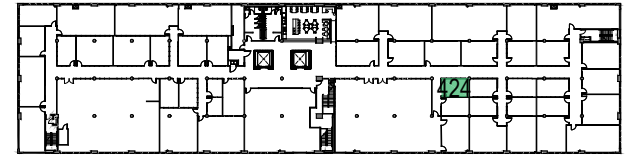

Key Plan

North Arrow

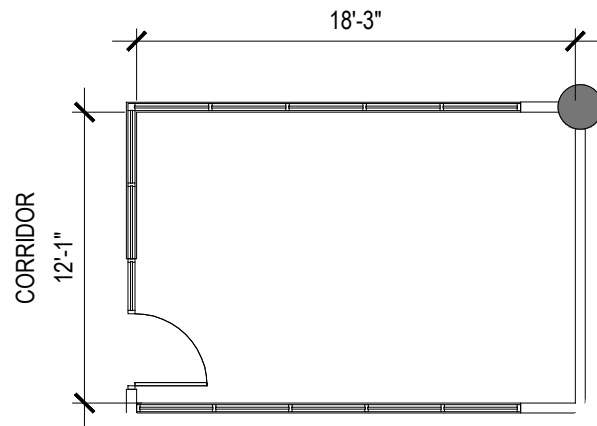

SUITE A #424

- \$940/ mo. unfurnished for 12 month term
- furnished/month-to-month options available
- Additional expenses include internet/phone services, electricity (sub-metered), and commercial liability insurance.

Fourth Floor - Suite 424
222 SF Net / 320 SF Gross

Buchholz Architects

123 Columbia Turnpike Suite 204A
Florham Park, NJ 07932
973.746.0100 Phone
Info@buchholzgroup.com

BUILDING 78

78 JOHN MILLER WAY

KEARNY, NJ 07032

Date:
6-Feb-17

Scale:
NTS

Project Number:
0714-1577

LEASING DEPT.

HUGO NEU REALTY MANAGEMENT LLC
(973) 968-5955
www.kearnypoint.com



Drawing:
LP-424

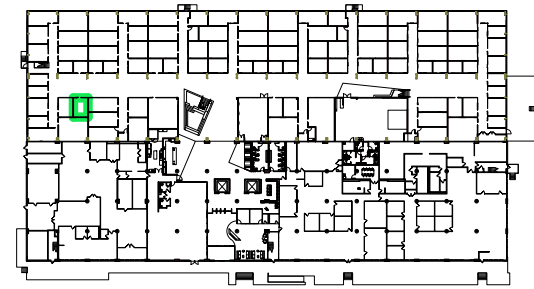
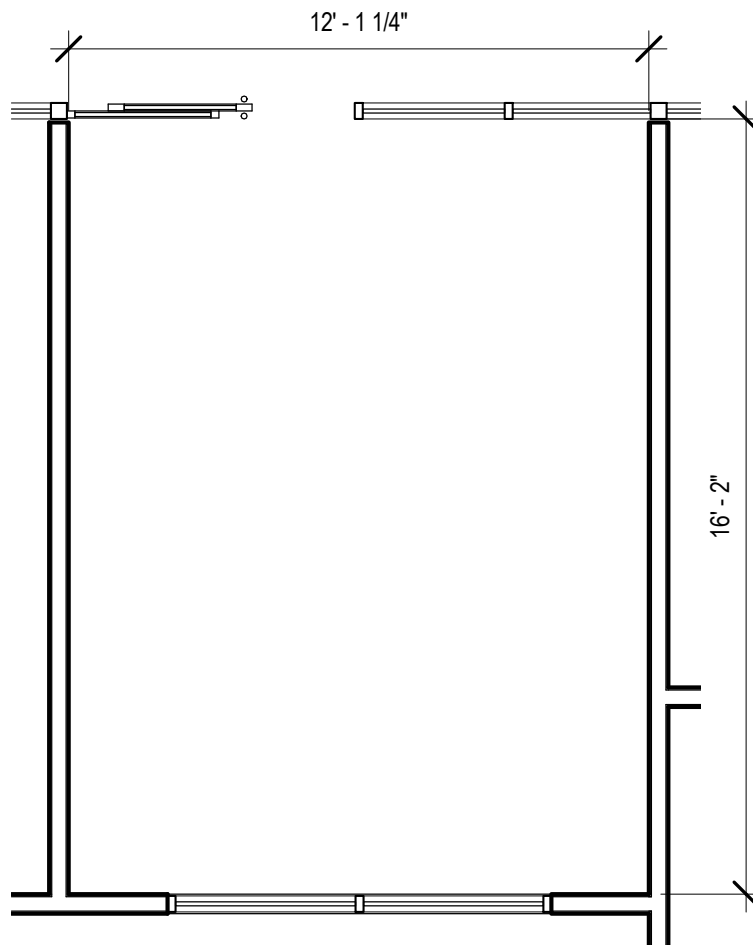

SUITEA #1008

- \$1,050/ mo. unfurnished for 12 month term
- furnished/month-to-month options available
- Additional expenses include electricity (sub-metered), and commercial liability insurance.

UNIT 1008
209 USF / 314 RSF

BUILDING 78

78 John Miller Way, Kearny, NJ 07032

Date: 12/30/2019 Scale: N.T.S.

LEASE PLAN

UNIT 1008 PLAN

LP-L1 1008

KEARNY POINT

HUGO NEU REALTY MANAGEMENT LLC

LEASING: 973-968-5955

STUDIOS
architecture

588 BROADWAY, SUITE 702-NEW YORK, NY 10012-212 431 4512

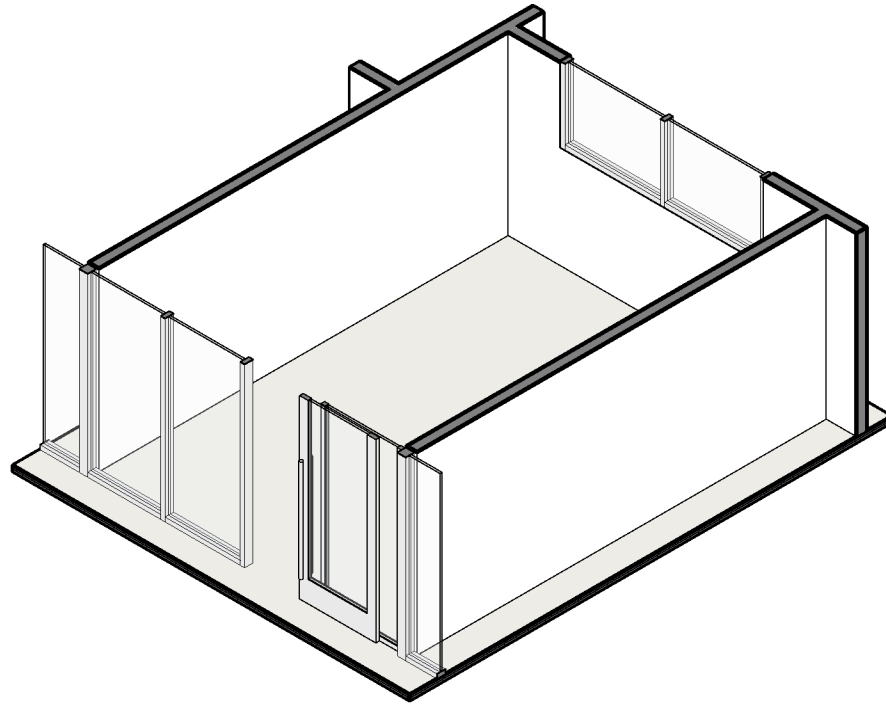
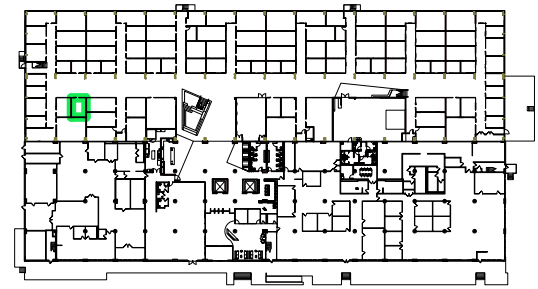

SUITEA #1008

- \$1,050/ mo. unfurnished for 12 month term
- furnished/month-to-month options available
- Additional expenses include electricity (sub-metered), and commercial liability insurance.

UNIT 1008
209 USF / 314 RSF

BUILDING 78

78 John Miller Way, Kearny, NJ 07032

Date: 12/30/2019 Scale: N.T.S.

LEASE PLAN

UNIT 1008 AXON

LP-L1 1008.1

KEARNY POINT

HUGO NEU REALTY MANAGEMENT LLC

LEASING: 973-968-5955

STUDIOS
architecture

588 BROADWAY, SUITE 702-NEW YORK, NY 10012-212 431 4512

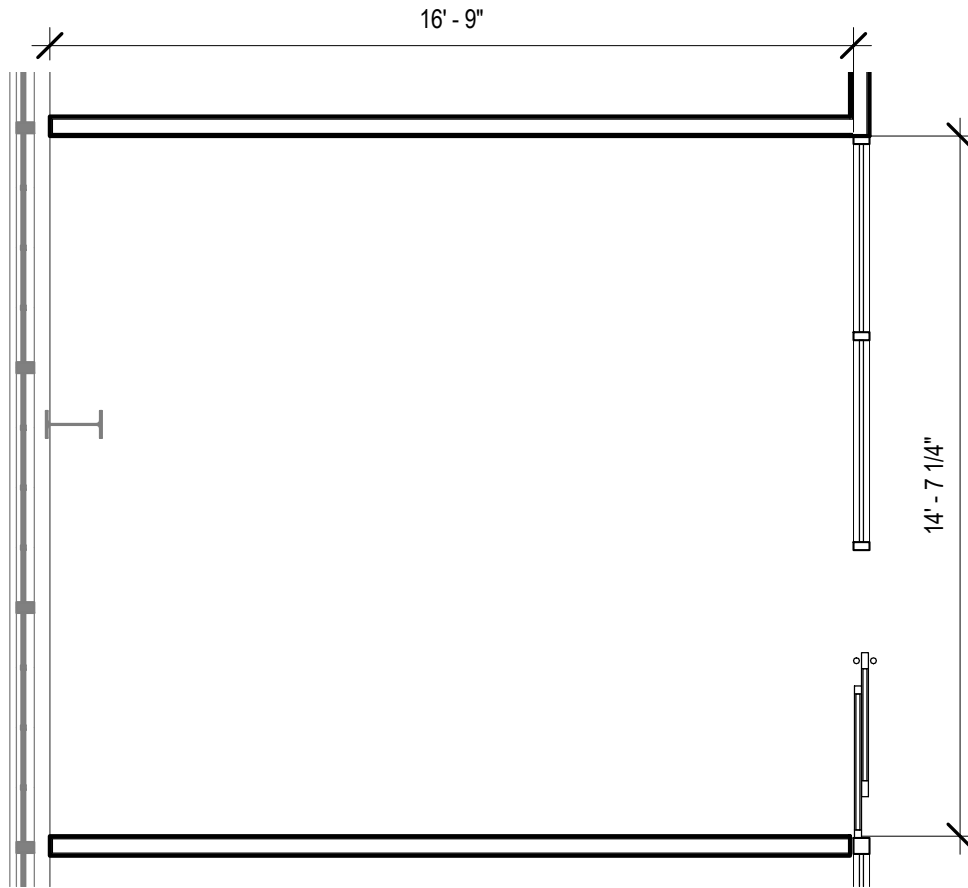
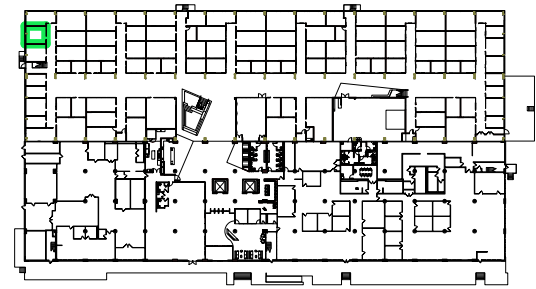

SUITE B #1017

- Ground floor unit
- window unit
- \$1,395/ mo. unfurnished for 12 month term
- Includes all expenses except electricity (sub-metered), in-suite janitorial, and commercial liability insurance

UNIT 1017
267 USF / 401 RSF

BUILDING 78

78 John Miller Way, Kearny, NJ 07032

Date: 12/30/2019 Scale: N.T.S.

LEASE PLAN

UNIT 1017 PLAN

LP-L1 1017

KEARNY POINT

HUGO NEU REALTY MANAGEMENT LLC
(973) 771-6413

STUDIOS
architecture

588 BROADWAY, SUITE 702-NEW YORK, NY 10012-212 431 4512

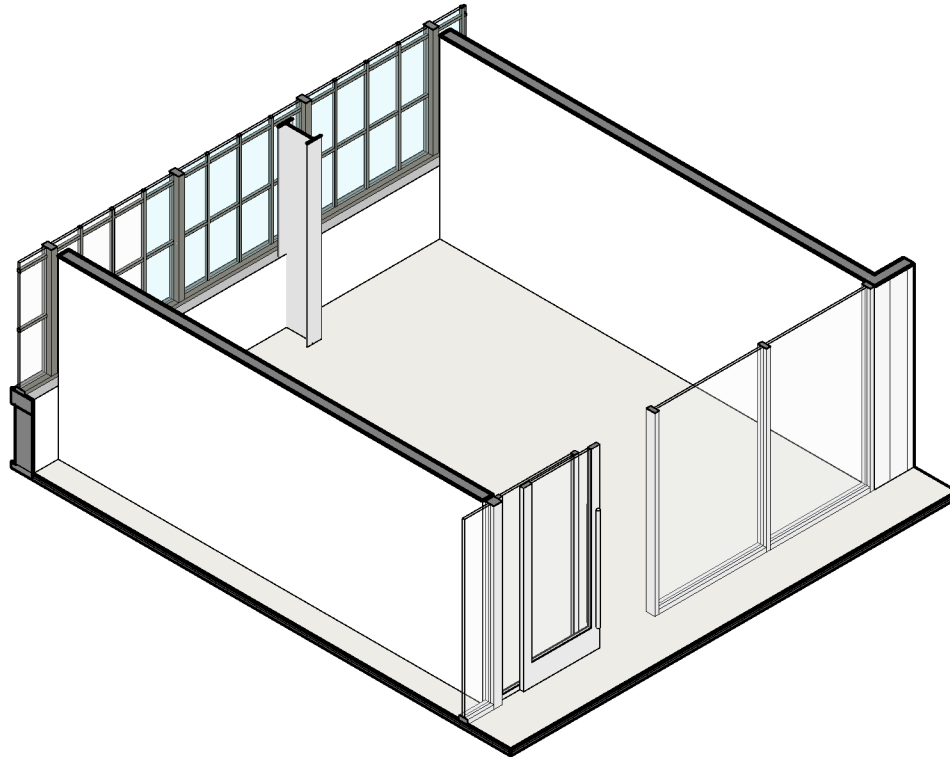
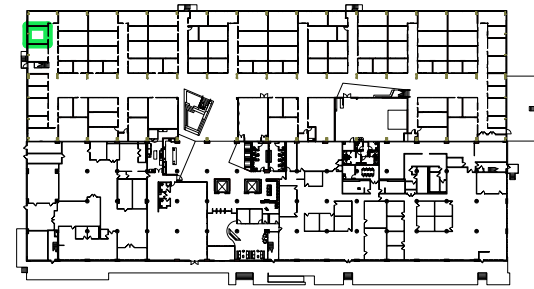

SUITE B #1017

- Ground floor unit
- window unit
- \$1,395/ mo. unfurnished for 12 month term
- Includes all expenses except electricity (sub-metered), in-suite janitorial, and commercial liability insurance

UNIT 1017
267 USF / 401 RSF

BUILDING 78

78 John Miller Way, Kearny, NJ 07032

Date: 12/30/2019 Scale: N.T.S.

LEASE PLAN

UNIT 1017 AXON

LP-L1 1017.1

KEARNY POINT

HUGO NEU REALTY MANAGEMENT LLC
(973) 771-6413

STUDIOS
architecture

588 BROADWAY, SUITE 702-NEW YORK, NY 10012-212 431 4512

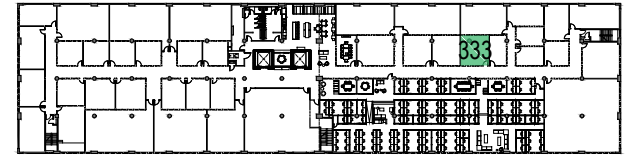
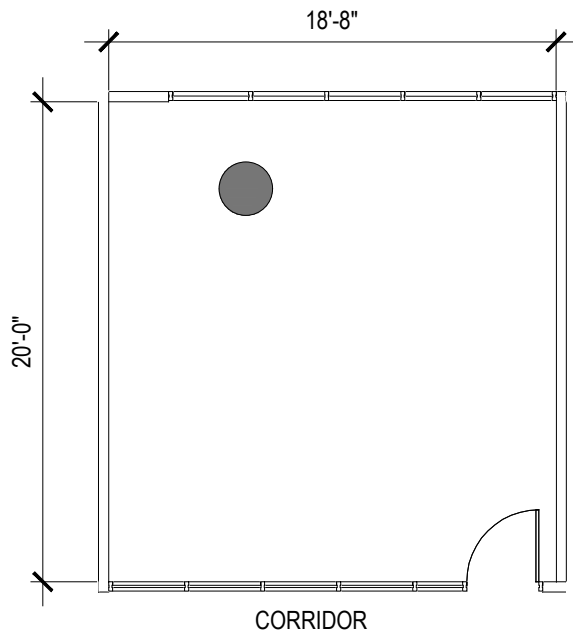

Key Plan

North Arrow

SUITE B #333

- \$1,495 / mo. unfurnished for 12 month term
- Includes all expenses except electricity (sub-metered), internet/phone, in-suite janitorial, and commercial liability insurance

Third Floor - Suite 333
373 SF Net / 518 SF Gross

BUILDING 78 | 78 JOHN MILLER WAY | KEARNY, NJ 07032

LEASING DEPT.
HUGO NEU REALTY MANAGEMENT LLC
(973) 968-5955
www.kearneypoint.com



Drawing:
LP-333

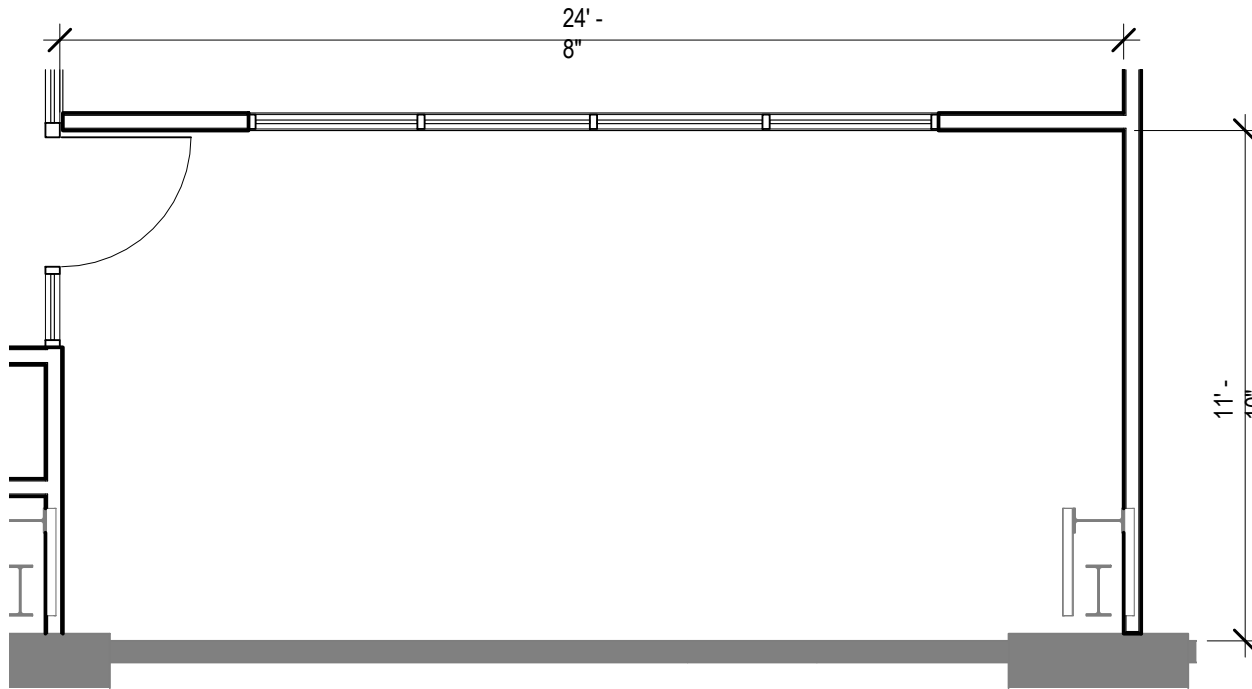
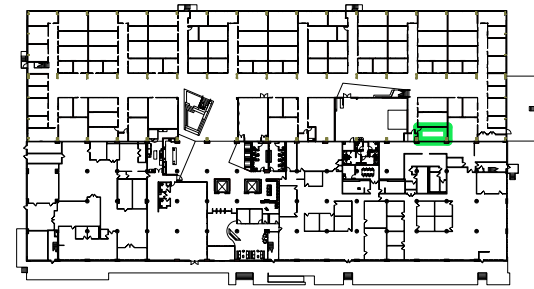

SUITE C #1097

- Ground floor unit
- Exposed brick
- \$1,450/ mo. unfurnished for 12 month term
- Includes all expenses except electricity (sub-metered), in-suite janitorial, and commercial liability insurance

UNIT 1097
302 USF / 453 RSF

BUILDING 78

78 John Miller Way, Kearny, NJ 07032

Date: 12/30/2019 Scale: N.T.S.

LEASE PLAN

UNIT 1097 PLAN

LP-L1 1097

KEARNY POINT

HUGO NEU REALTY MANAGEMENT LLC

LEASING: 973-968-5955

STUDIOS
architecture

588 BROADWAY, SUITE 702-NEW YORK, NY 10012-212 431 4512

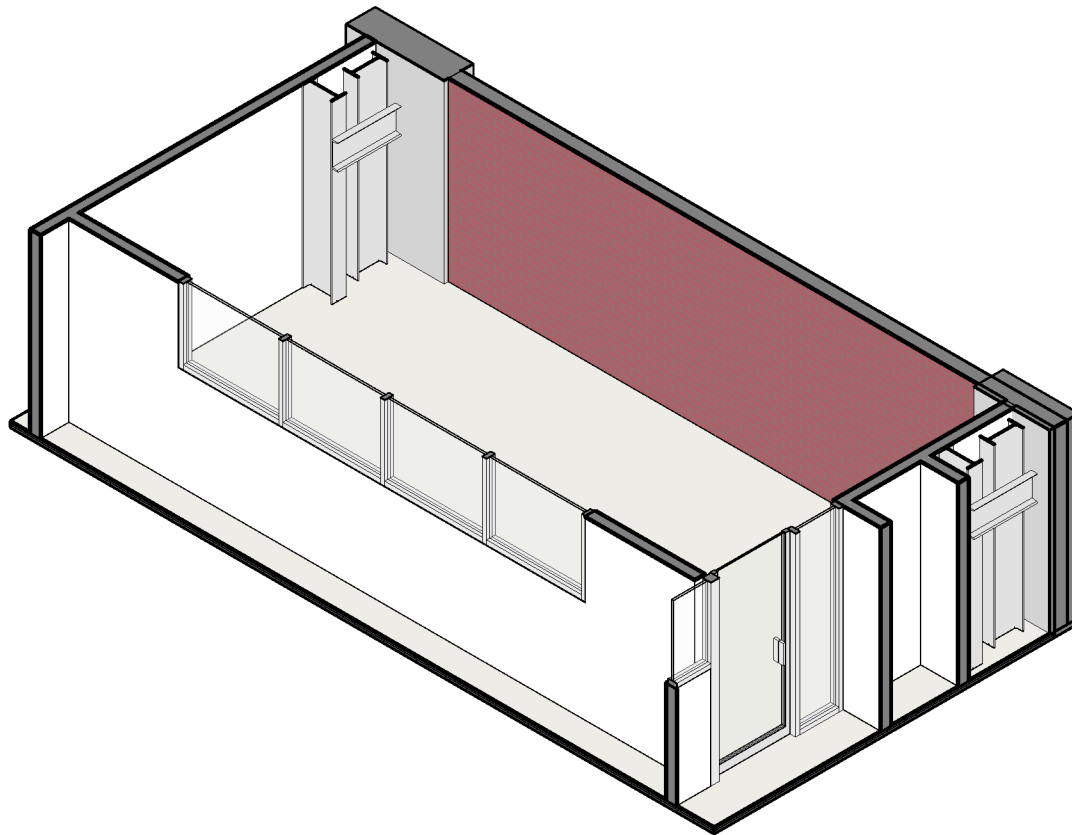
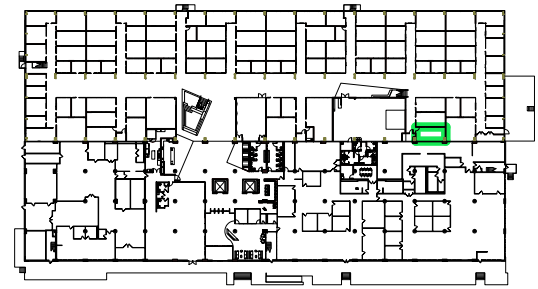

SUITE C #1097

- Ground floor unit
- Exposed brick
- \$1,450/ mo. unfurnished for 12 month term
- Includes all expenses except electricity (sub-metered), in-suite janitorial, and commercial liability insurance

UNIT 1097
302 USF / 453 RSF

BUILDING 78

78 John Miller Way, Kearny, NJ 07032

Date: 12/30/2019 Scale: N.T.S.

LEASE PLAN

UNIT 1097 AXON

LP-L1 1097.1

KEARNY POINT

HUGO NEU REALTY MANAGEMENT LLC

LEASING: 973-968-5955

STUDIOS
architecture

588 BROADWAY, SUITE 702-NEW YORK, NY 10012-212 431 4512

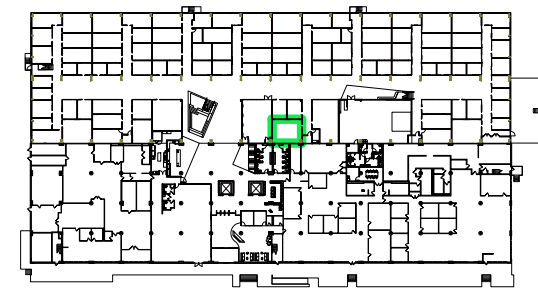
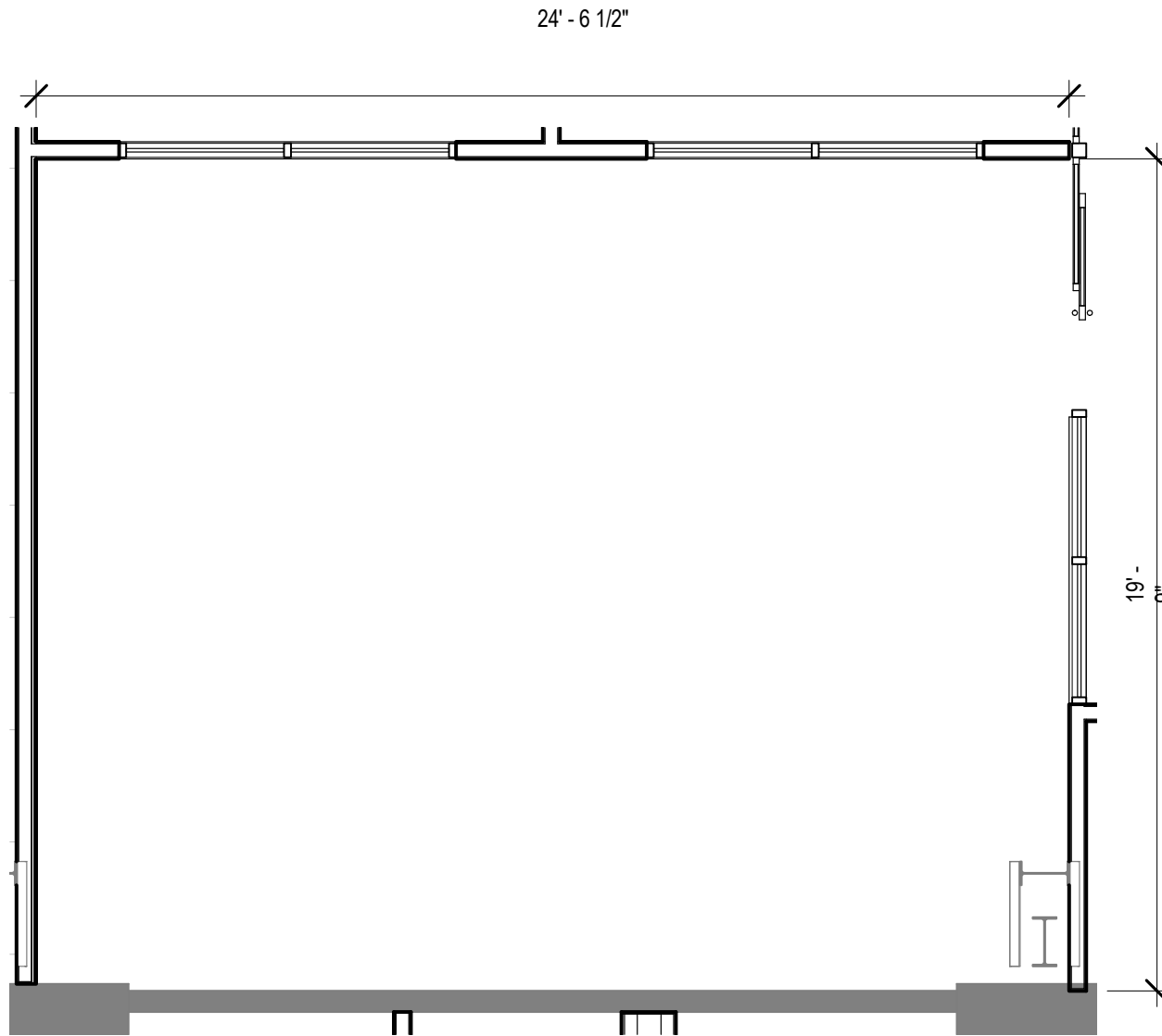

SUITEC #1108

- Ground floor unit
- Exposed brick
- \$1,950 mo. unfurnished for 12 month term
- Includes all expenses except electricity (sub-metered), in-suite janitorial, and commercial liability insurance

UNIT 1108
502 USF / 753 RSF

BUILDING 78

78 John Miller Way, Kearny, NJ 07032

Date: 12/30/2019 Scale: N.T.S.

LEASE PLAN

UNIT 1108 PLAN

LP-L1 1108

KEARNY POINT

HUGO NEU REALTY MANAGEMENT LLC

LEASING: 973-968-5955

STUDIOS
architecture

588 BROADWAY, SUITE 702-NEW YORK, NY 10012-212 431 4512

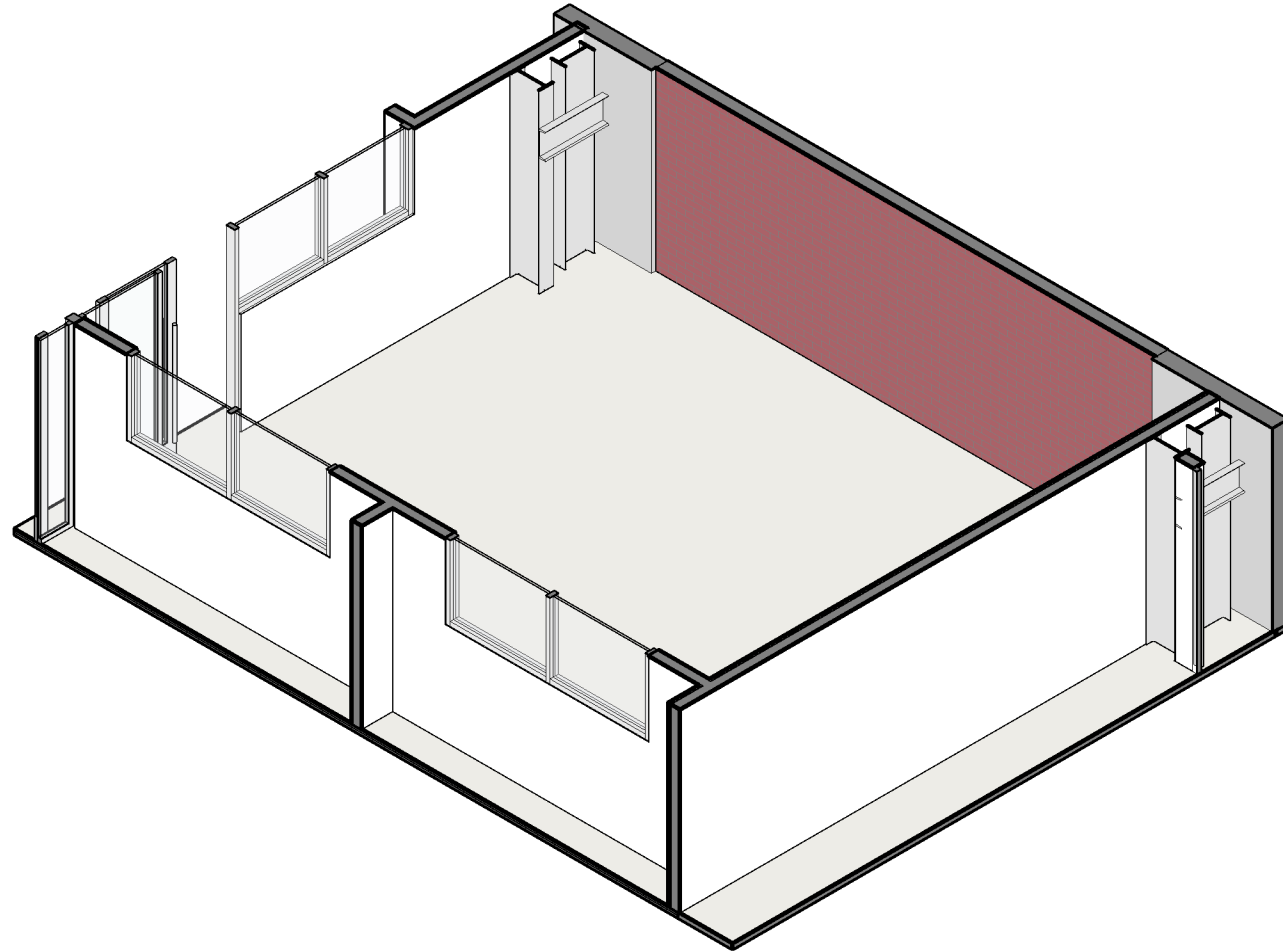
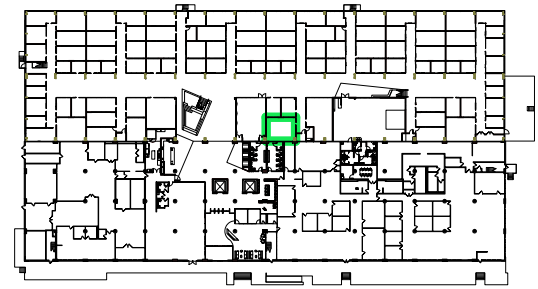

SUITEC #1108

- Ground floor unit
- Exposed brick
- \$1,950 mo. unfurnished 12 month term
- Includes all expenses except electricity (sub-metered), in-suite janitorial, and commercial liability insurance

UNIT 1108
502 USF / 753 RSF

BUILDING 78

78 John Miller Way, Kearny, NJ 07032

Date: 12/30/2019 Scale: N.T.S.

LEASE PLAN

UNIT 1108 AXON

LP-L1 1108.1

KEARNY POINT

HUGO NEU REALTY MANAGEMENT LLC

LEASING: 973-968-5955

STUDIOS
architecture

588 BROADWAY, SUITE 702-NEW YORK, NY 10012-212 431 4512

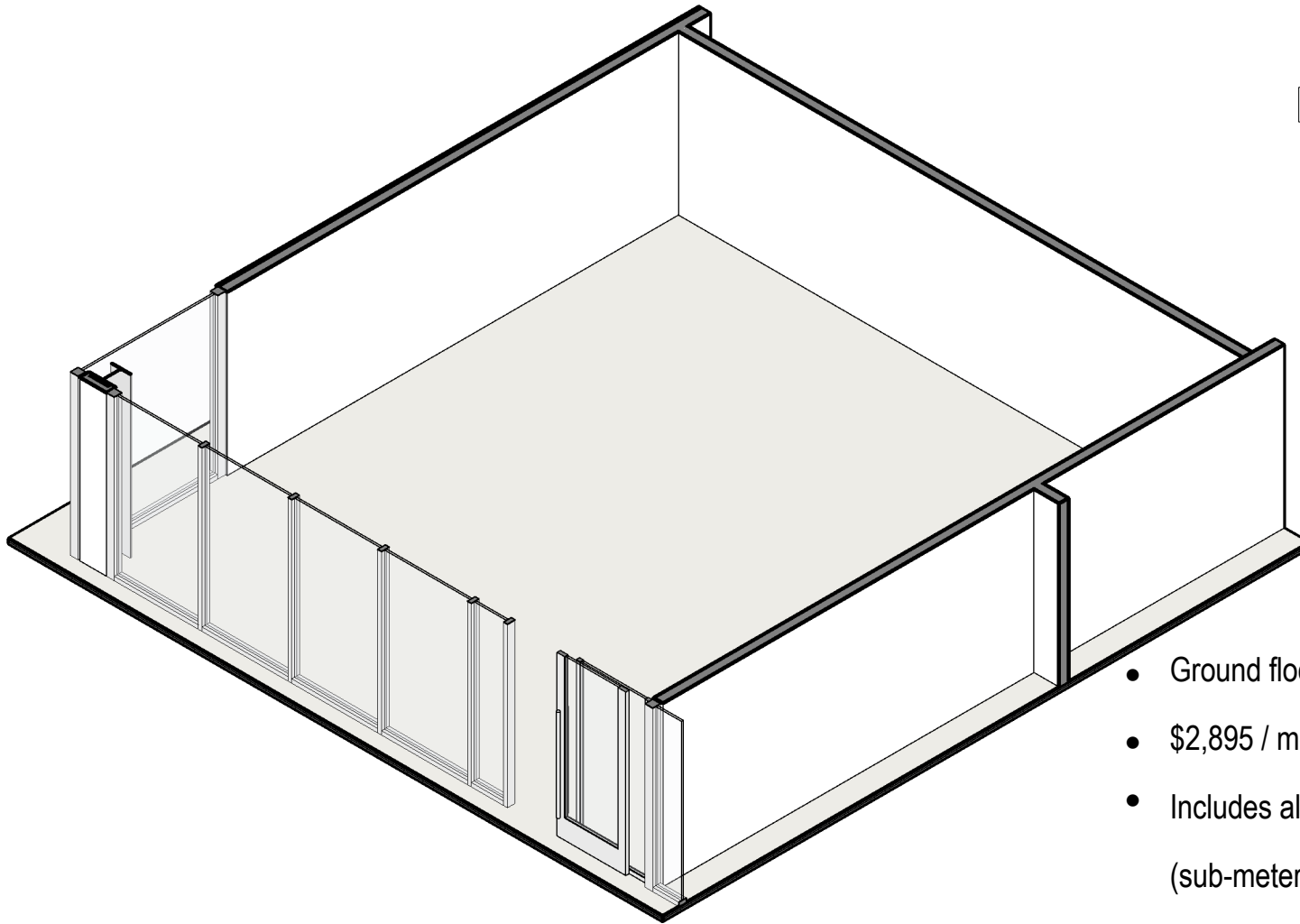
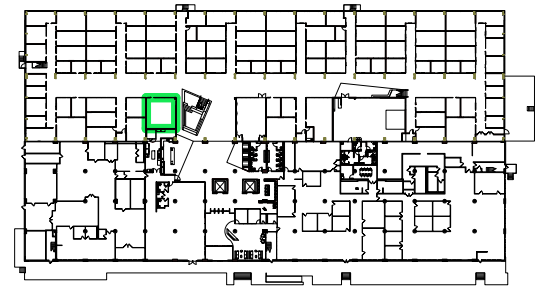

SUITE C #1001

- Ground floor unit
- \$2,895 / mo. unfurnished for 12 month term
- Includes all expenses except electricity (sub-metered), in-suite janitorial, and commercial liability insurance

UNIT 1001
662 USF / 993 RSF

BUILDING 78

78 John Miller Way, Kearny, NJ 07032

Date: 12/30/2019 Scale: N.T.S.

LEASE PLAN

UNIT 1001 AXON

LP-L1 1001.1

KEARNY POINT

HUGO NEU REALTY MANAGEMENT LLC

LEASING: 973-968-5955

STUDIOS
architecture

588 BROADWAY, SUITE 702-NEW YORK, NY 10012-212 431 4512

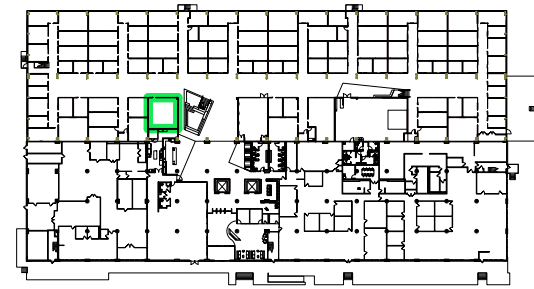
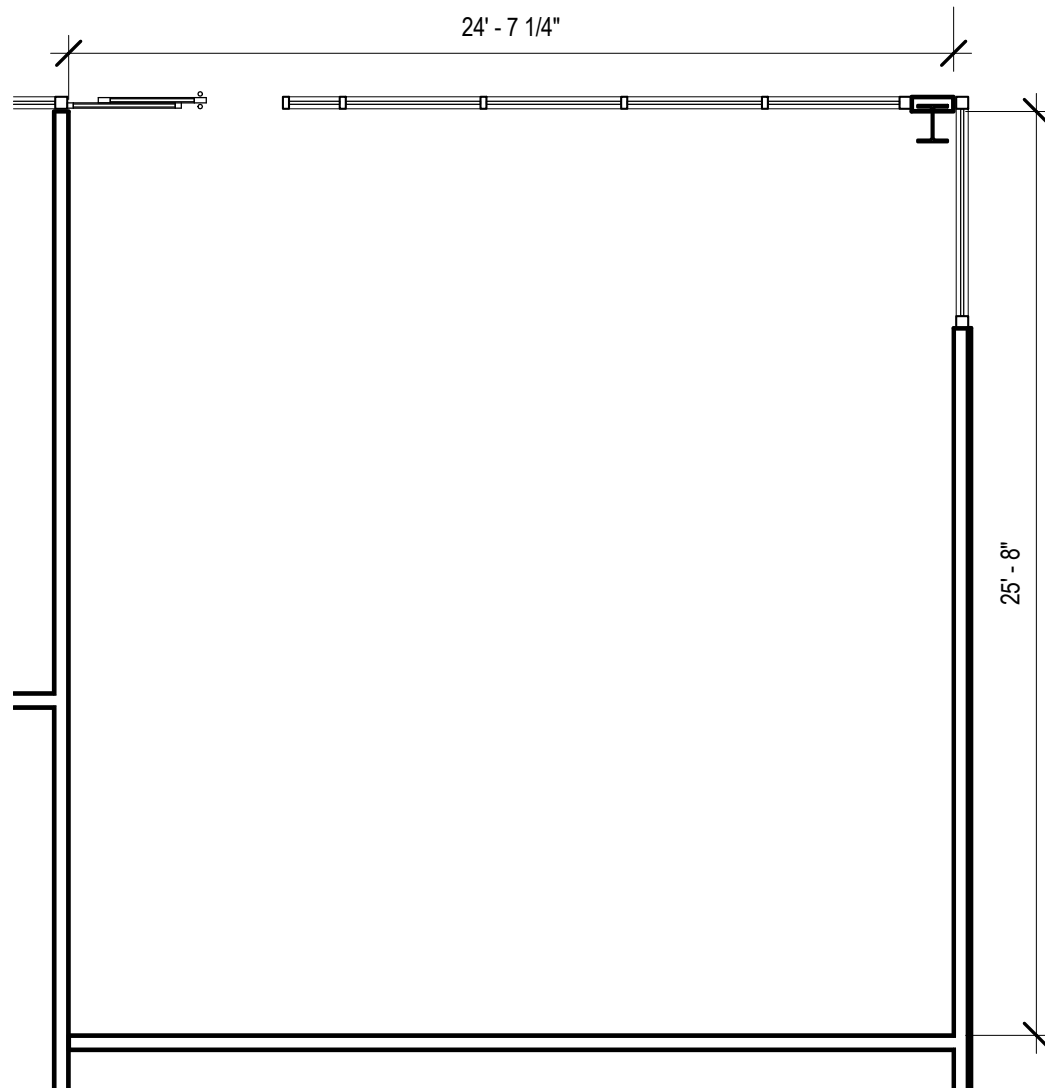

SUITE C #1001

- Ground floor unit
- \$2,895 / mo. unfurnished for 12 month term
- Includes all expenses except electricity (sub-metered), in-suite janitorial, and commercial liability insurance

UNIT 1001
662 USF / 993 RSF

BUILDING 78

78 John Miller Way, Kearny, NJ 07032

Date: 12/30/2019 Scale: N.T.S.

LEASE PLAN

UNIT 1001 PLAN

LP-L1 1001

KEARNY POINT

HUGO NEU REALTY MANAGEMENT LLC

LEASING: 973-968-5955

STUDIOS
architecture

588 BROADWAY, SUITE 702-NEW YORK, NY 10012-212 431 4512

CORRIDOR

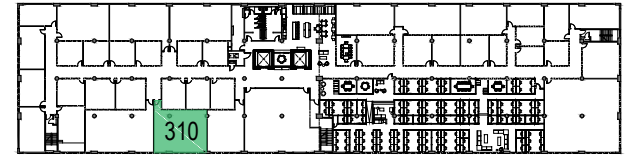
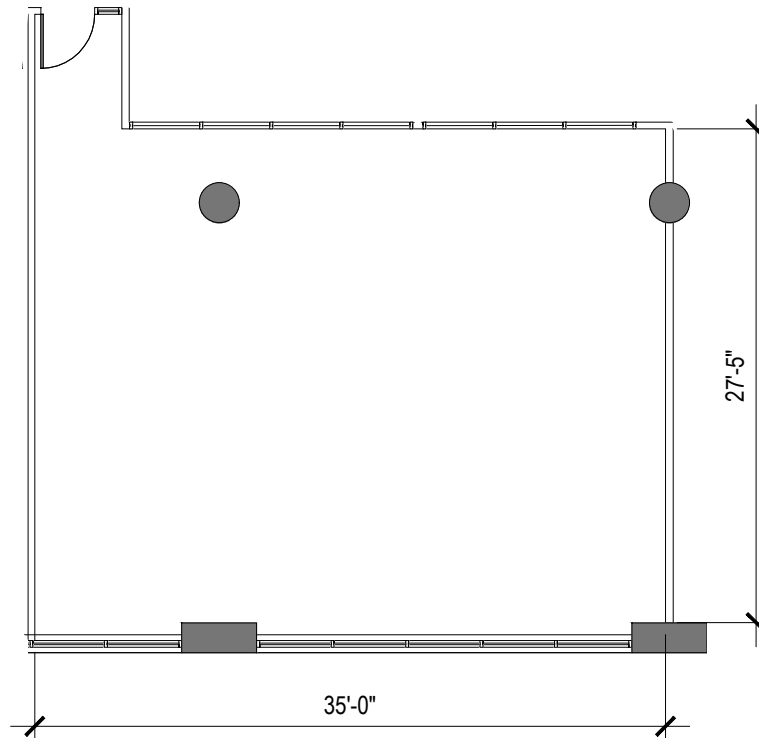

Key Plan



North Arrow

SUITE C #310

- \$3,200 / mo. unfurnished for 12 month term
- window unit
- Includes all expenses except electricity (sub-metered), internet/phone, in-suite janitorial, and commercial liability insurance

Third Floor - Suite 310
1,010 SF Net / 1,403 SF Gross

BUILDING 78 | 78 JOHN MILLER WAY | KEARNY, NJ 07032

LEASING DEPT.
HUGO NEU REALTY MANAGEMENT LLC
(973) 968-5955
www.kearnypoint.com



Drawing:
LP-310

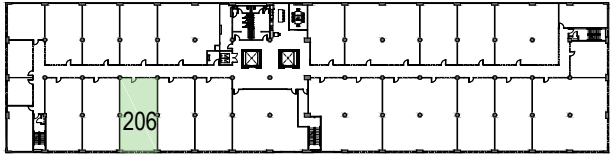
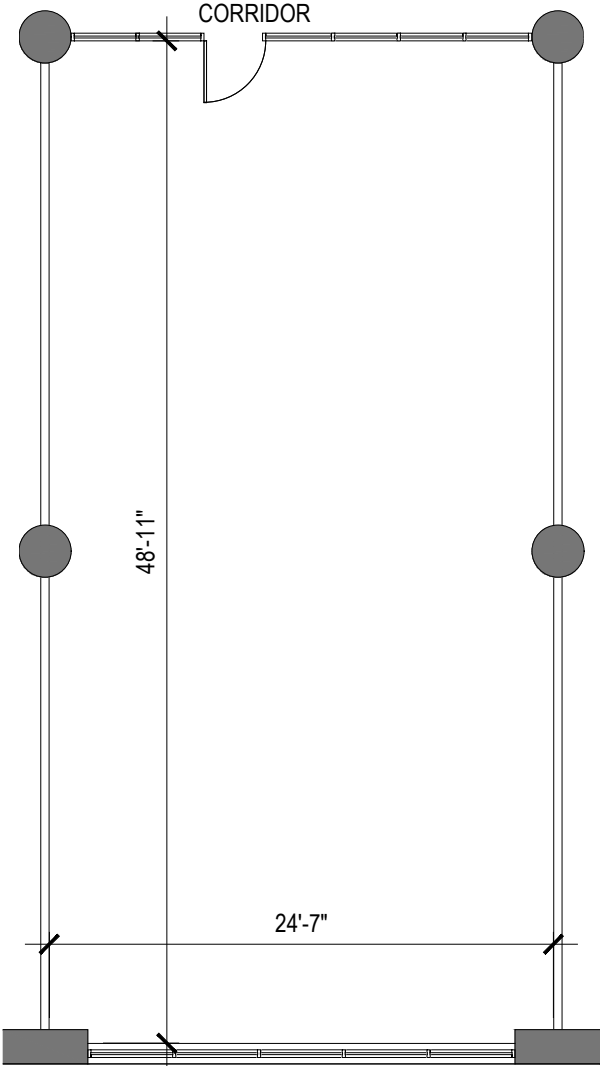

Key Plan

North Arrow

SUITE C #206

- \$3,300 / mo. unfurnished for 12 month term
- Includes all expenses except electricity (sub-metered), internet/phone, in-suite janitorial, and commercial liability insurance

Second Floor - Suite 206
1,196 SF Net / 1,603 SF Gross

BUILDING 78 | 78 JOHN MILLER WAY | KEARNY, NJ 07032

LEASING DEPT.
HUGO NEU REALTY MANAGEMENT LLC
(973) 968-5955
www.kearnypoint.com

Drawing:
LP-206

- **Modern working environment featuring cutting-edge design**
- **Super-fast and secure hard-wired internet connections (Ethernet)+ Wi-Fi**
- **24/7 access to the building**
- **5 free hours of conference room time per month**
- **Full-service gym and fitness classes**
- **Mail and package handling, b&w / color printing and scanning**
- **Invitations to all of our exclusive community/networking events with like-minded professionals**
- **Break out rooms for private calling**
- **Guest reception and greeting**
- **Daily cleaning services**
- **Free refreshments - coffee, filtered water, tea, fruit, snacks**
- **Onsite staff available from 9am-5pm, Mon-Fri**

AMENITIES & BUILDING FEATURES

Q3 2020



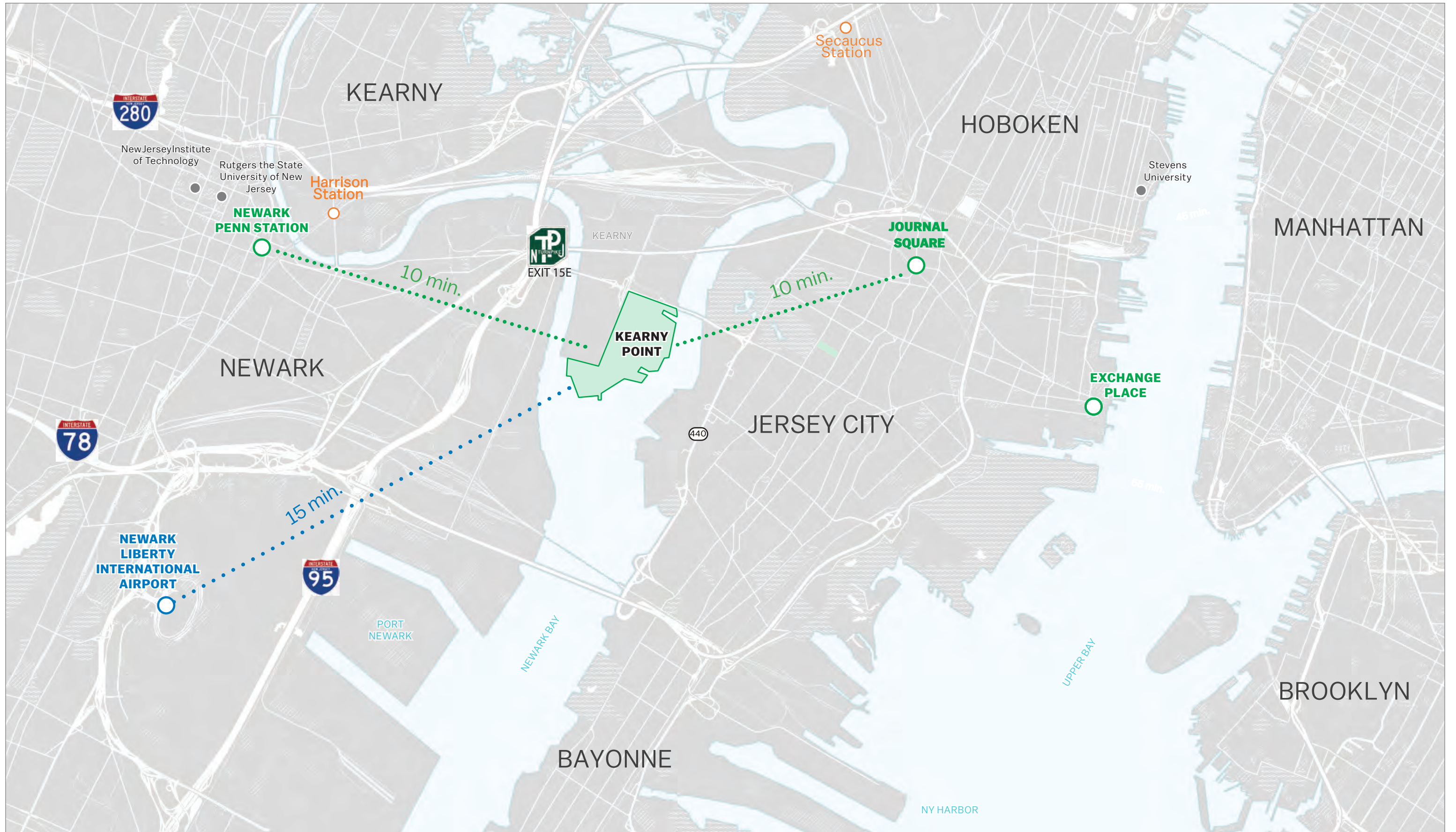

REGIONAL ACCESSIBILITY

Q3 2020

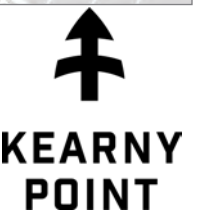

CONTACT US

www.kearnypoint.com

LEASING

General Inquiries: info@kearnypoint.com

Phone: 973-968-5955

Nick Shears - nshears@hugoneu.com

Ashlee Sullivan - asullivan@hugoneu.com

Norma Figueroa - nfigueroa@hugoneu.com

THANK YOU

Q3 2020

