

EXECUTIVE HUB
AT GAILLARDIA PARKWAY



TOTAL BUSINESS SOLUTION

The Executive Hub at Gaillardia Parkway is Oklahoma City's premiere business solution for talented executives looking for a professional environment in a convenient location. Tenants have access to a wide range of amenities, including high-tech conference rooms, modern suites, ample collaboration areas, administrative services and more.



AMENITIES & FEATURES:

- ✓ Executive suites of varying size
 - ✓ Furnished & unfurnished options
- ✓ Six state-of-the-art conference rooms
 - ✓ Massive 4K interactive, collaborative displays
 - ✓ Video conferencing
 - ✓ Multi-party conference calls
- ✓ Staffed reception area
- ✓ High speed internet and WiFi
- ✓ Printers, copiers, scanners and shredders
- ✓ Mail services
- ✓ Kitchen with complimentary beverage service
- ✓ Community room
- ✓ Golf course views
- ✓ Free outdoor parking
 - ✓ Limited parking garage spaces available for additional fee
- ✓ Security surveillance
- ✓ 24-hour accessibility

EXECUTIVE HUB AT GAILLARDIA PARKWAY

4801 Gaillardia Parkway, Suite 200
Oklahoma City, OK 73142
info@okcexecutivehub.com
405.492.7900

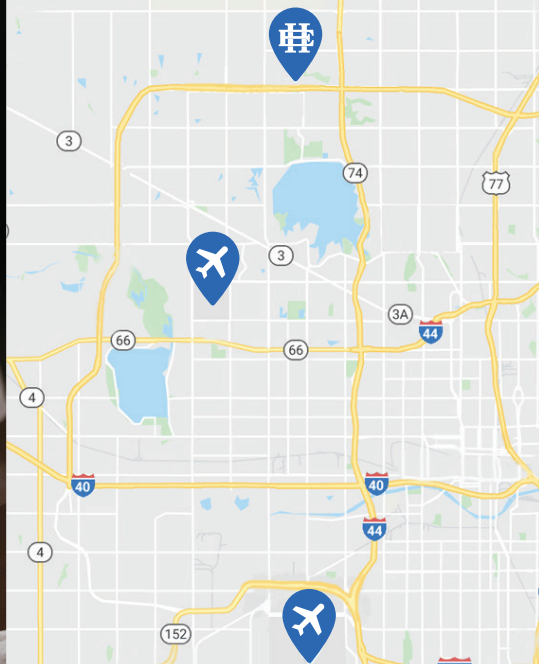

WELCOME TO THE AREA

There is no shortage of conveniences in close proximity to the Executive Hub at Gaillardia Parkway. In the vicinity are a variety of restaurants, country clubs and health facilities. Furthermore, Executive Hub lessees and guests have quick access to the John Kilpatrick Turnpike and Lake Hefner Parkway for easy transport to neighboring suburbs, downtown OKC and local airports.

Nearby Restaurants:



- Bricktown Brewery
- Charleston's
- Earl's Rib Palace
- Hideaway Pizza
- Interurban
- Mahogany Prime Steakhouse
- Neighborhood Jam
- Panera Bread
- Revolve Pizza Kitchen
- Starbucks

Nearby Country Clubs:



- Gaillardia Country Club
- The Greens Country Club
- Quail Creek Country Club

Convenient Location:



- Easy Turnpike and Parkway access
- 20 min. to downtown OKC
- 20 min. to Wiley Post Airport
- 25 min. to Will Rogers World Airport
- Close proximity to Edmond



SUITE OPTIONS

The Executive Hub at Gaillardia Parkway offers a variety of suite options to suit your needs and budget. Golf course views and contemporary furnishings with ample storage are just a few of the lease options available at the Executive Hub. Suites start at just \$900 per month.

STUDIO SUITE

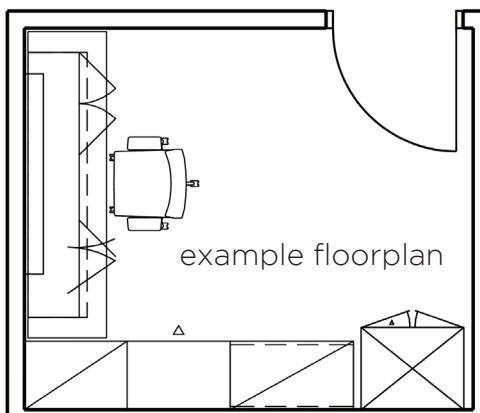

JUNIOR SUITE

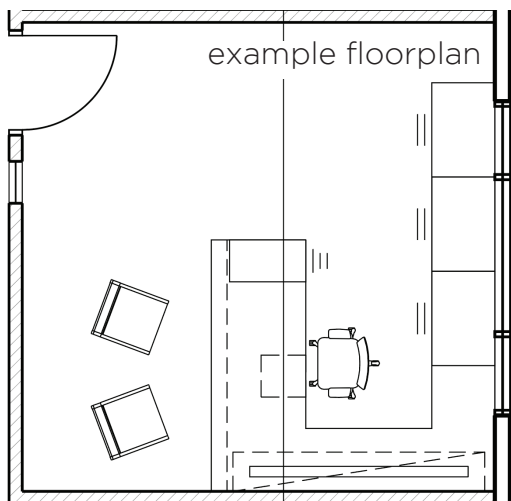

EXECUTIVE SUITE

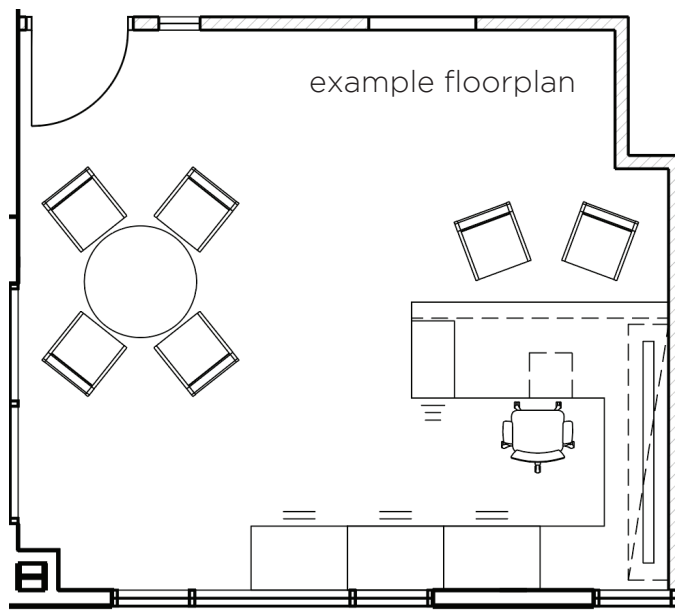

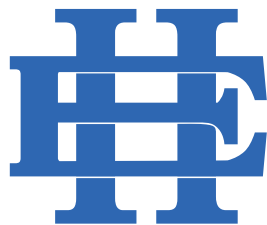

Convenience | Sophistication | Collaboration

For more detailed information or to schedule a tour,
contact info@okcexecutivehub.com