

2727

BROADWAY
UPPER WEST SIDE, NEW YORK

Between West 104th and
West 105th Streets

APPROXIMATE SIZE

500 SF

ASKING RENT

\$5,500 per Month

FRONTAGE

10 FT

COMMENTS

- Former AT&T
- Strong Retail Corridor
- Dense Residential Population
- Steps from the 1 Subway Line
- .5 Mile from Riverside Park
- Blocks from Columbia University

NEIGHBORS

Serafina • McDonald's • Café du Soleil • Ollie's •
Ben & Jerry's • Papa John's Pizza • Tap A Keg •
Duane Reade • Suba Pharmacy • Bank of America
• Cure Urgent Care • Straus Park • Riverside Park

TRANSPORTATION

 **M104**

TERM

Negotiable

POSSESSION

Immediate

JAMES FAMULARO
President

JOSEPH E. HARARY
Associate
jh@meridiancapital.com
212.468.5978

RETAIL FOR LEASE



 **MERIDIAN**
RETAIL LEASING

All information supplied is from sources deemed reliable and is furnished subject to errors, omissions, modifications, removal of the listing from sale or lease, and to any listing conditions, including the rates and manner of payment of commissions for particular offerings imposed by Meridian Capital Group. This information may include estimates and projections prepared by Meridian Capital Group with respect to future events, and these future events may or may not actually occur. Such estimates and projections reflect various assumptions concerning anticipated results. While Meridian Capital Group believes these assumptions are reasonable, there can be no assurance that any of these estimates and projections will be correct. Therefore, actual results may vary materially from these estimates and projections. Any square footage dimensions set forth are approximate.

2727 BROADWAY

UPPER WEST SIDE, NEW YORK | Between W 104th and W 105th Streets

RETAIL FOR LEASE

INTERIOR



JAMES FAMULARO
President

JOSEPH E. HARARY
Associate
jh@meridiancapital.com
212.468.5978



All information supplied is from sources deemed reliable and is furnished subject to errors, omissions, modifications, removal of the listing from sale or lease, and to any listing conditions, including the rates and manner of payment of commissions for particular offerings imposed by Meridian Capital Group. This information may include estimates and projections prepared by Meridian Capital Group with respect to future events, and these future events may or may not actually occur. Such estimates and projections reflect various assumptions concerning anticipated results. While Meridian Capital Group believes these assumptions are reasonable, there can be no assurance that any of these estimates and projections will be correct. Therefore, actual results may vary materially from these estimates and projections. Any square footage dimensions set forth are approximate.

2727 BROADWAY

UPPER WEST SIDE, NEW YORK | Between W 104th and W 105th Streets

RETAIL FOR LEASE

FLOORPLAN

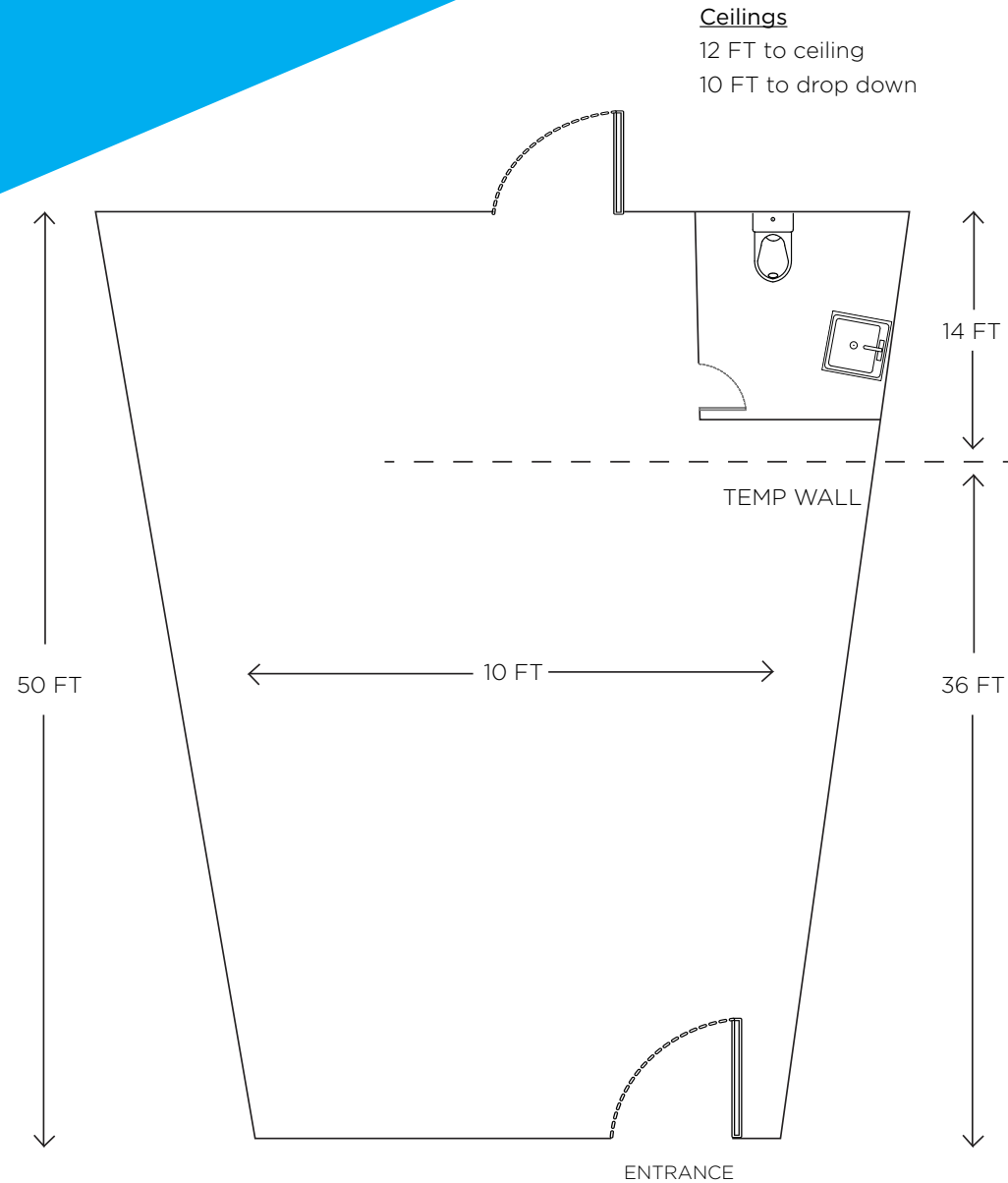

JAMES FAMULARO
President

JOSEPH E. HARARY
Associate
jh@meridiancapital.com
212.468.5978



All information supplied is from sources deemed reliable and is furnished subject to errors, omissions, modifications, removal of the listing from sale or lease, and to any listing conditions, including the rates and manner of payment of commissions for particular offerings imposed by Meridian Capital Group. This information may include estimates and projections prepared by Meridian Capital Group with respect to future events, and these future events may or may not actually occur. Such estimates and projections reflect various assumptions concerning anticipated results. While Meridian Capital Group believes these assumptions are reasonable, there can be no assurance that any of these estimates and projections will be correct. Therefore, actual results may vary materially from these estimates and projections. Any square footage dimensions set forth are approximate.

2727 BROADWAY

UPPER WEST SIDE, NEW YORK | Between W 104th and W 105th Streets

RETAIL FOR LEASE

YOUR NEIGHBORHOOD

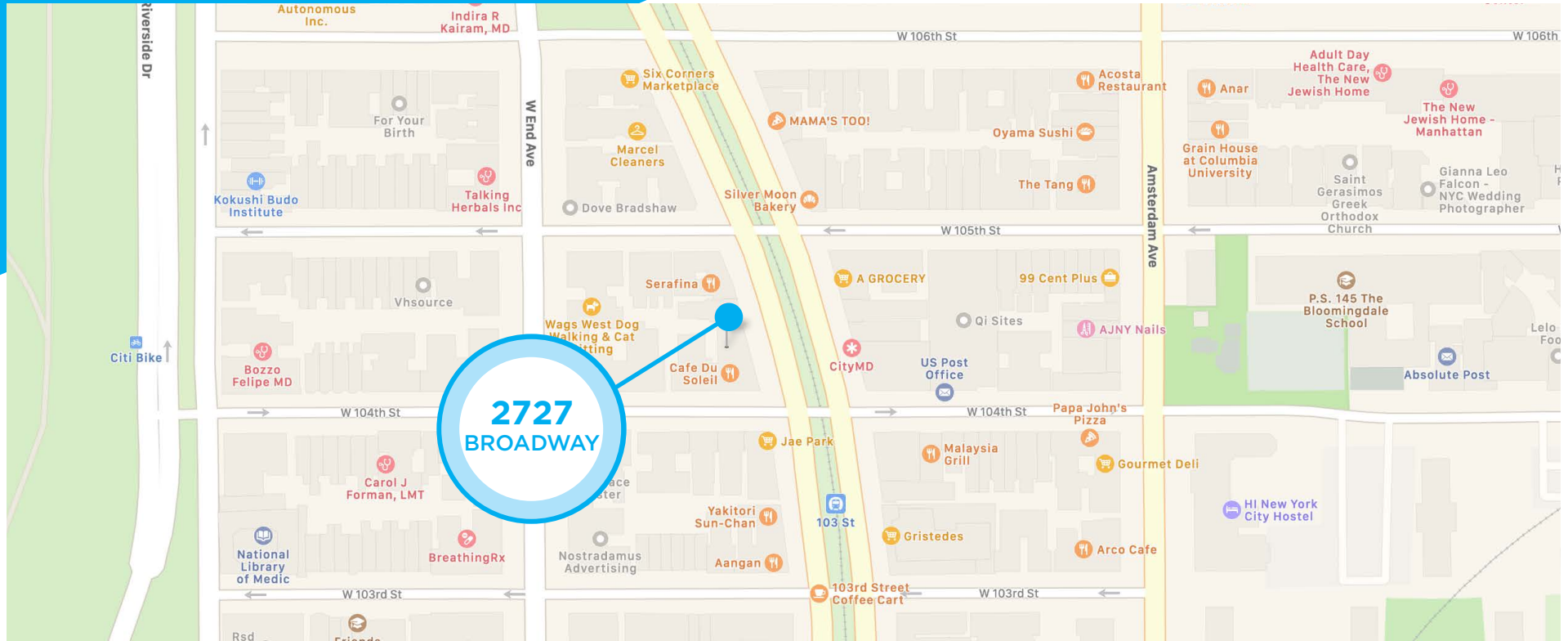

JAMES FAMULARO
President

JOSEPH E. HARARY
Associate
jh@meridiancapital.com
212.468.5978



All information supplied is from sources deemed reliable and is furnished subject to errors, omissions, modifications, removal of the listing from sale or lease, and to any listing conditions, including the rates and manner of payment of commissions for particular offerings imposed by Meridian Capital Group. This information may include estimates and projections prepared by Meridian Capital Group with respect to future events, and these future events may or may not actually occur. Such estimates and projections reflect various assumptions concerning anticipated results. While Meridian Capital Group believes these assumptions are reasonable, there can be no assurance that any of these estimates and projections will be correct. Therefore, actual results may vary materially from these estimates and projections. Any square footage dimensions set forth are approximate.