



For Lease | \pm 5,093 SF Dock-High Warehouse

9369 Dowdy Drive, San Diego, CA 92126



For Lease | ± 5,093 SF Warehouse

9369 Dowdy Dr., San Diego, CA 92126



Property Features:

- Rare dock-high warehouse in Miramar
- 4,558 SF Warehouse area
- 535 SF Office area
- Excellent truck access
- 20' Clear height
- Dock-high loading
- Sprinklered
- Building signage
- Zoning: IL-2-1
- Centrally located in the Miramar Submarket
- Excellent access to 805, 15 & 163 Freeways

Lease Rate: \$1.10/SF NNN

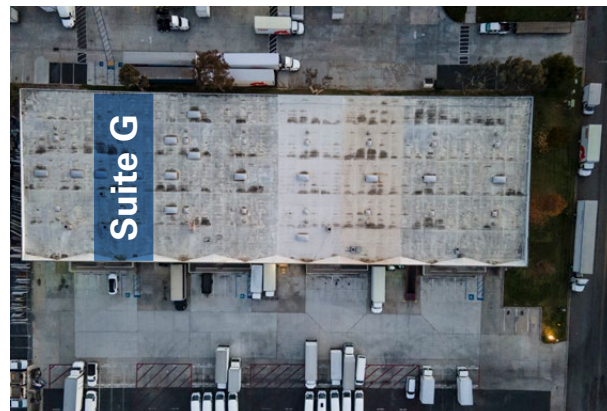

NEWMARK

For information, please contact:

Paul Britvar

Director

t 858-875-3609

pbritvar@ngkf.com

CA RE Lic. #01946354

Brent Bohlken

Senior Managing Director

t 858-875-3616

bbohlken@ngkf.com

CA RE Lic. #01022607

San Diego Office

4655 Executive Dr., Suite 800

San Diego, CA 92121

Newmark DRE #01355491

For Lease | ± 5,093 SF Warehouse

9369 Dowdy Dr., San Diego, CA 92126

SUITE C FLOOR PLAN
± 5,093 SF

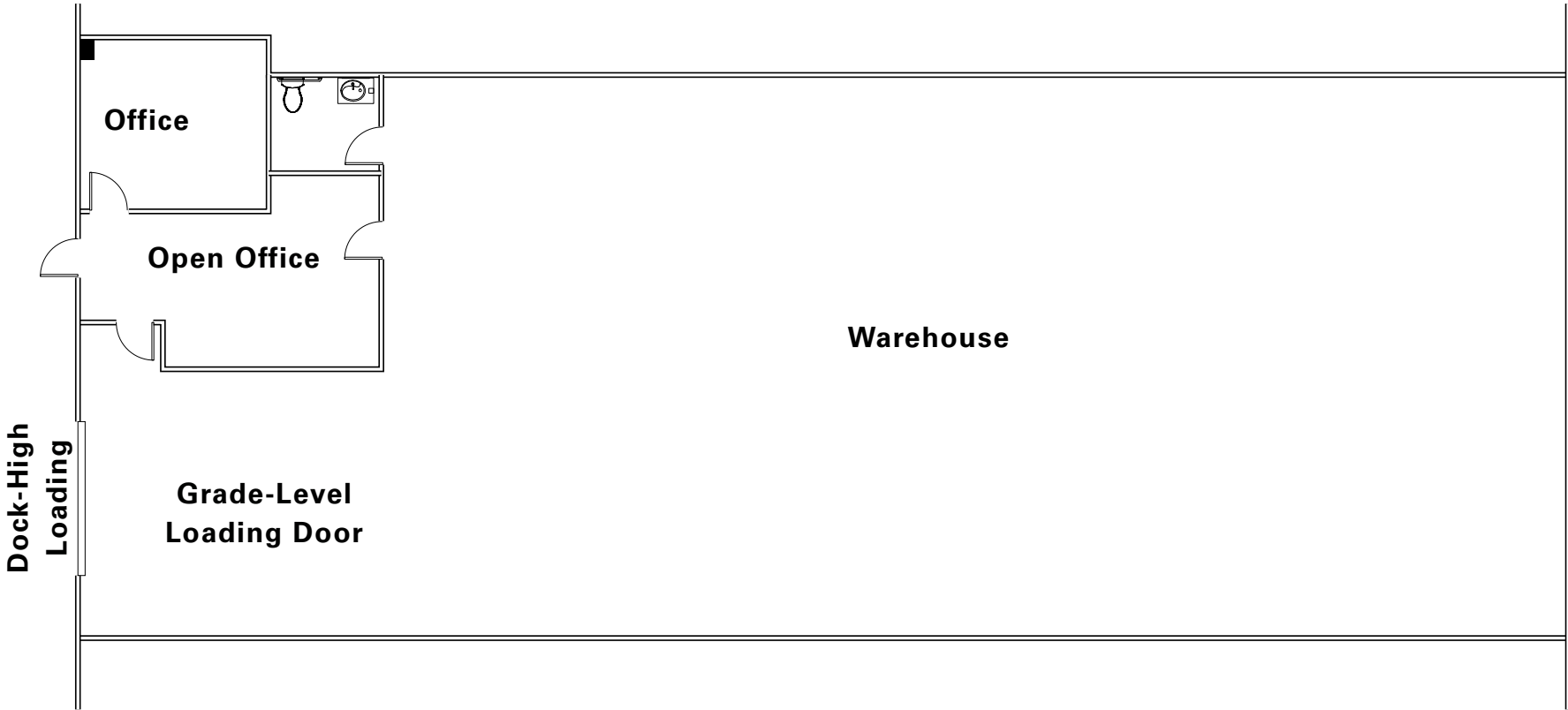

NEWMARK

The broker for a purchaser of the property shall be entitled to receive a real estate commission only in the event that broker and the property's owner execute a written commission agreement containing the manner of calculation of that commission and all conditions to its payment, and the satisfaction of those conditions. Absent a written agreement to the contrary between that broker and Newmark that broker shall not look to Newmark for payment of such a commission or any other compensation. Although all information furnished regarding property for sale, lease, or financing has been obtained from sources deemed to be reliable, that information has not been verified by Newmark and no express representation is made nor is any to be implied as to the accuracy thereof. That information is subject to errors, omissions, change of price, rental or other conditions, prior sale, lease or financing, or withdrawal without notice and to any special conditions imposed by Newmark's client.

For Lease | ± 5,093 SF Warehouse

9369 Dowdy Dr., San Diego, CA 92126

SITE PLAN

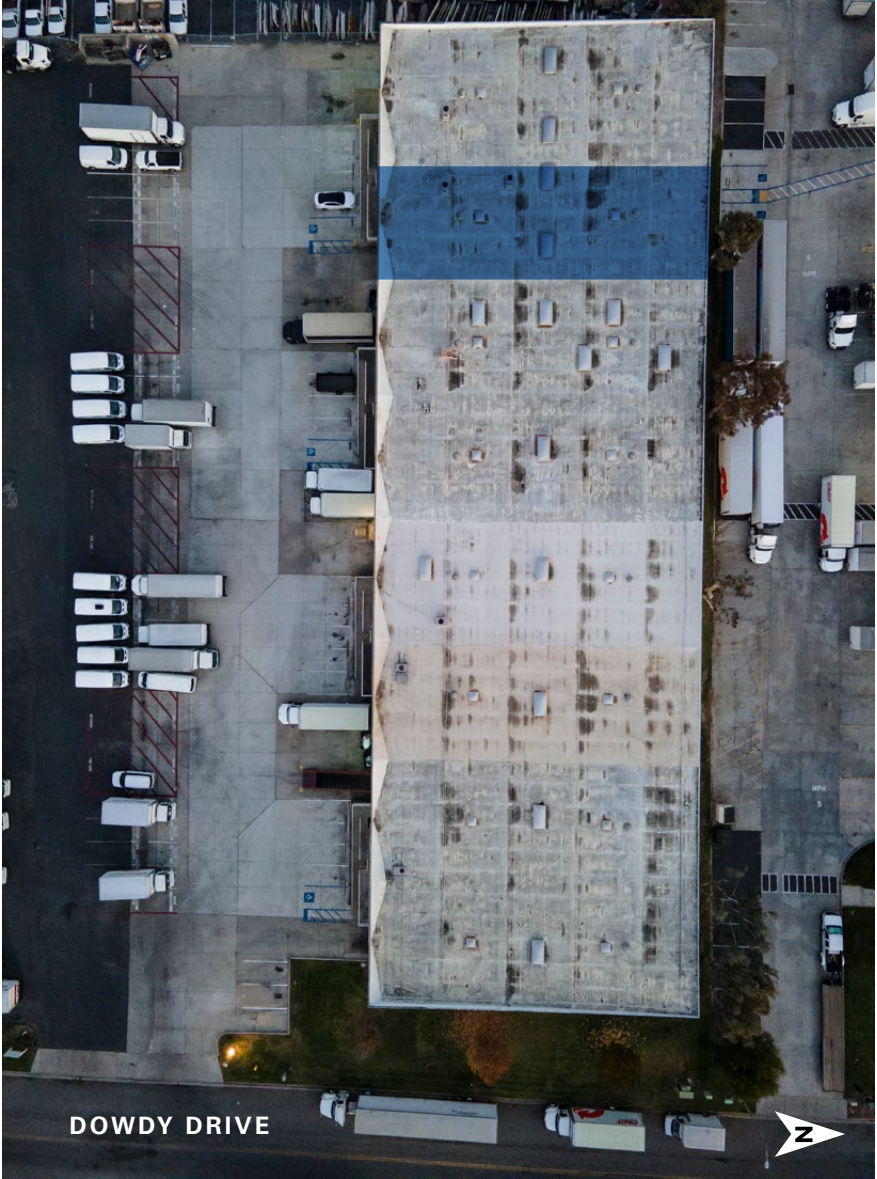
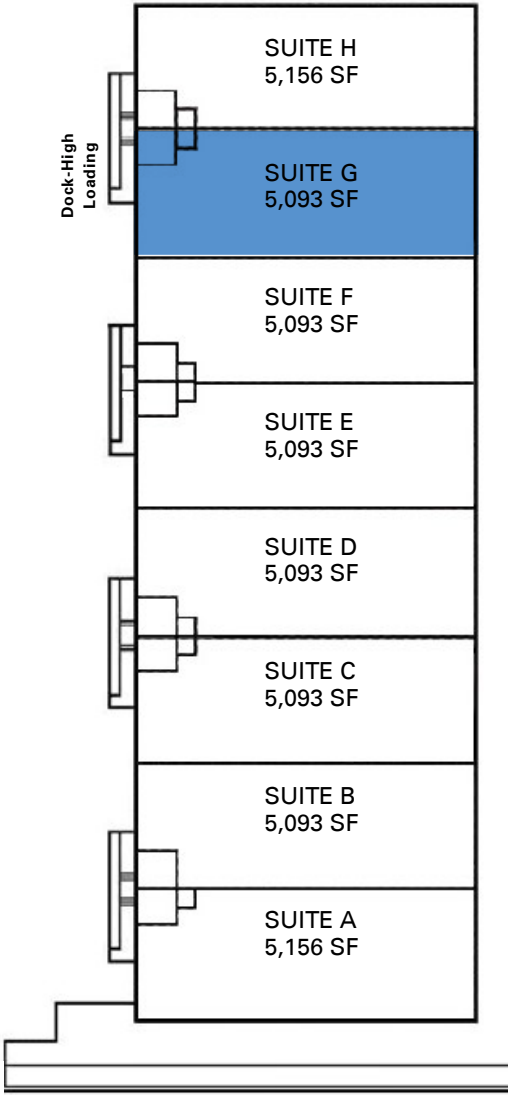

NEWMARK