



INDUSTRIAL SPACE AVAILABLE FOR LEASE - ± 24,142 SF

13315 - Q Carowinds Boulevard | Charlotte, North Carolina 28273



Christopher Skibinski, SIOR
Principal | Managing Director
704.412.5606
chris.skibinski@avisonyoung.com

Henry Lobb
Senior Vice President
704.469.5964
henry.lobb@avisonyoung.com

Tom Tropeano
Vice President
704.413.0228
tom.tropeano@avisonyoung.com





INDUSTRIAL SPACE AVAILABLE FOR LEASE - ± 24,142 SF

13315 - Q Carowinds Boulevard | Charlotte, North Carolina 28273

Overview

Lakemont West Business Park consists of eight Class-A industrial buildings totaling 1,009,234 square feet. It covers 85.3 acres and includes anchor tenants such as Empire Distributors, Fidelitone, and General Fasteners Co.

Located within close proximity to the I-485/I-77 interchange, the Park offers quick and convenient access to highly efficient interstate systems.

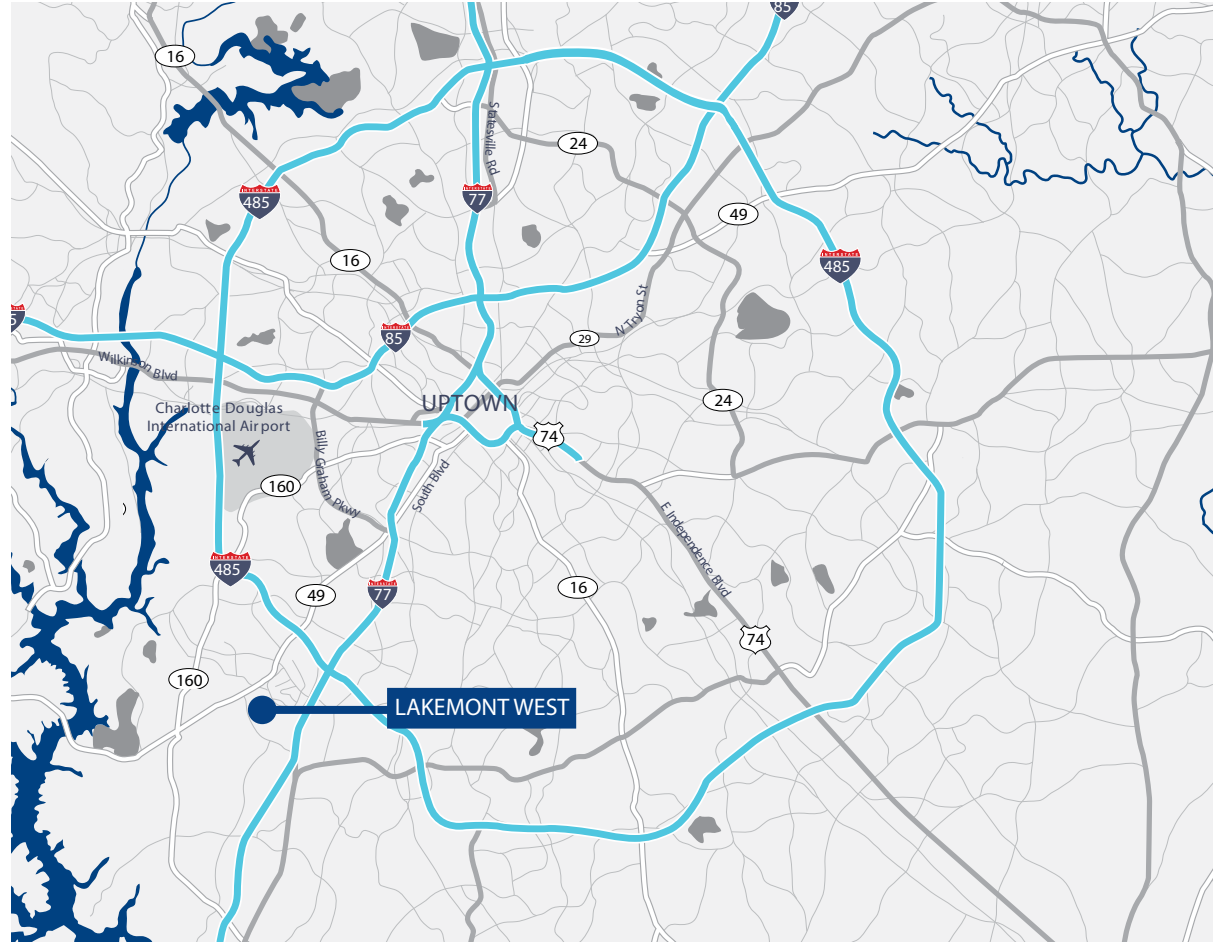

I-77	± 2 Miles
I-485	± 4 Miles
Charlotte Douglas Int'l Airport	± 13 Miles
Uptown Charlotte	± 14 Miles

Christopher Skibinski, SIOR
Principal | Managing Director
704.412.5606
chris.skibinski@avisonyoung.com

Henry Lobb
Senior Vice President
704.469.5964
henry.lobb@avisonyoung.com

Tom Tropeano
Vice President
704.413.0228
tom.tropeano@avisonyoung.com

521 E Morehead Street, Suite 101
Charlotte, NC 28202
704.531.5550
avisonyoung.com





INDUSTRIAL SPACE AVAILABLE FOR LEASE - \pm 24,142 SF

13315 - Q Carowinds Boulevard | Charlotte, North Carolina 28273

Floor Plan

13315-Q CAROWINDS BLVD. | BUILDING SPECS

Square Footage	
Total Area (SF)	136,106
Available SF	\pm 24,142
Office SF:	\pm 2,459
Property Features	
Year Built	1997
Building Depth	200'
Sprinkler	ESFR
Ceiling Height	24'
Column Spacing	40' x 40'
Dock Doors	Five (5) Dock High; One (1) Drive In
Dock Packages	Two (2) Pit levelers
Zoning	I-1
Construction Overview	
Construction	Concrete Tilt Up
Floor	6", 4,000 PSI

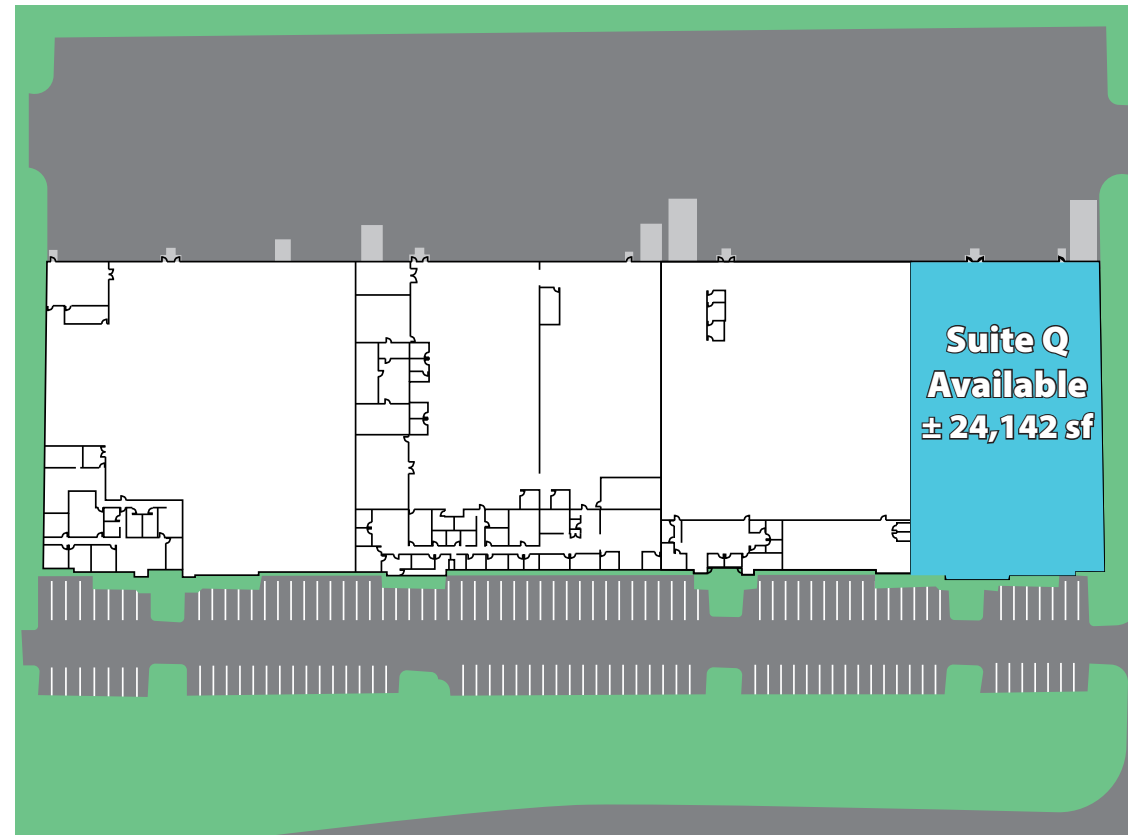

Christopher Skibinski, SIOR
Principal | Managing Director
704.412.5606
chris.skibinski@avisonyoung.com

Henry Lobb
Senior Vice President
704.469.5964
henry.lobb@avisonyoung.com

Tom Tropeano
Vice President
704.413.0228
tom.tropeano@avisonyoung.com

521 E Morehead Street, Suite 101
Charlotte, NC 28202
704.531.5550
avisonyoung.com





INDUSTRIAL SPACE AVAILABLE FOR LEASE - ± 24,142 SF

13315 - Q Carowinds Boulevard | Charlotte, North Carolina 28273

Floor Plan



- Dock High
- Drive-in

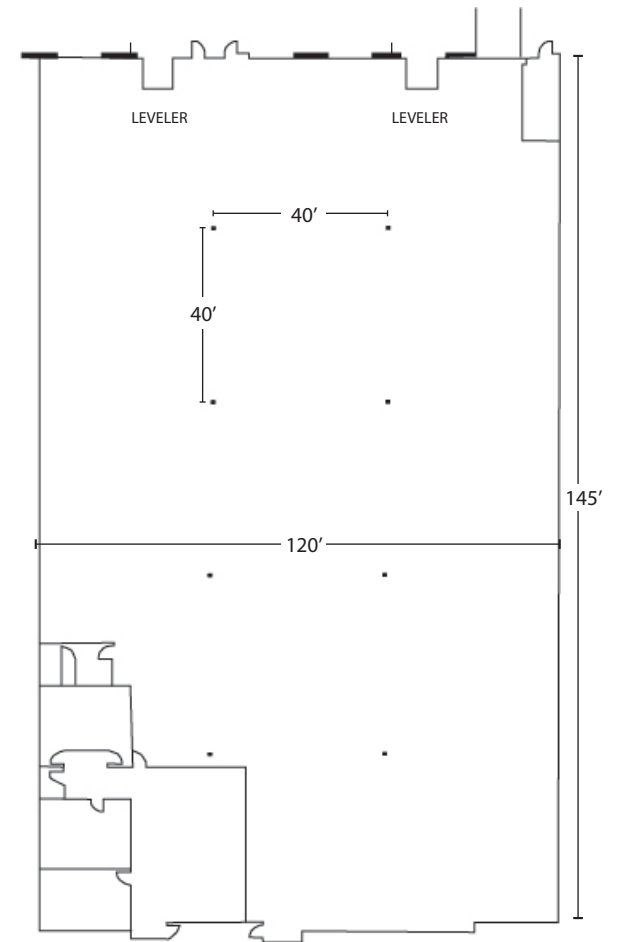

© 2019 Avison Young - North Carolina, LLC.
All rights reserved.

E. & O.E.: The information contained herein was obtained from sources which we deem reliable and, while thought to be correct, is not guaranteed by Avison Young.

Christopher Skibinski, SIOR
Principal | Managing Director
704.412.5606
chris.skibinski@avisonyoung.com

Henry Lobb
Senior Vice President
704.469.5964
henry.lobb@avisonyoung.com

Tom Tropeano
Vice President
704.413.0228
tom.tropeano@avisonyoung.com

521 E Morehead Street, Suite 101
Charlotte, NC 28202
704.531.5550
avisonyoung.com

