



## 2656 E. 29<sup>th</sup> Avenue Spokane, Washington 99223

### Property Features

- Space Available: 1,474 SF
- Near Lincoln Heights Shopping Center
- Zoning: CC2-DC
- Excellent Signage, Access and Visibility
- Former Office of H & R Block
- Neighboring Businesses
  - Rosauers
  - Pizza Hut
  - O'Reilly Auto Parts
  - Bank of America
- Year Built: 1976
- Parcel #: 35331.0505
- Owner is a Licensed Broker in Washington State
- Traffic Counts:
  - On 29<sup>th</sup> Ave: 19,700
  - On Regal St.: 11,200

**Lease Rate: \$12.00 PSF**  
Modified Gross



For More Information, Contact:

**Brent Johnson**

+1 509 622 3573

[brent.johnson@naiblack.com](mailto:brent.johnson@naiblack.com)

# 2656 E 29<sup>th</sup> Avenue

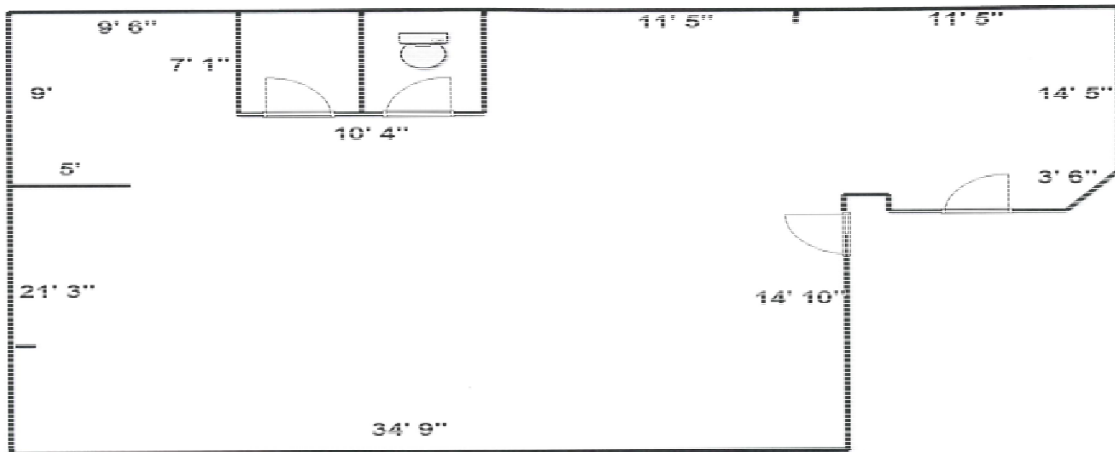

## 2018 Demographics:

Population	1 Mile Radius	13,790
	3 Mile Radius	80,206
	5 Mile Radius	165,889
Average Household Income	1 Mile Radius	\$78,871
	3 Mile Radius	\$88,290
	5 Mile Radius	\$72,810
2023 Estimated Population	1 Mile Radius	14,328
	3 Mile Radius	84,055
	5 Mile Radius	173,537

For More Information, Contact:

**Brent Johnson**

+1 509 622 3573

brent.johnson@naiblack.com

NAI Black respects the intellectual property rights of others. If you believe that your intellectual property rights have been violated by NAI Black or by a third party who has uploaded Content on our Site, please provide the following information to the NAI Black designated copyright agent as addressed below: a. A description of the copyrighted work or other intellectual property that you claim has been infringed; b. A specific description of where the material that you claim is infringing is located on the Site so the agent is able to locate it; c. An address, telephone number, and e-mail address where NAI Black can contact you and, if different, an e-mail address where the alleged infringing party, if not NAI Black, can contact you; d. A signed statement that you have a good-faith belief that the material use is not authorized by the copyright owner or other intellectual property rights owner, by its agent, or by law. e. A signed statement by you under penalty of perjury that the information in your notice is accurate and that you are the copyright or intellectual property owner or are authorized to act on the owner's behalf; After reviewing the complaint and determining if the complaint is valid, NAI Black will work to quickly remove the infringing material or disable access to it. Note: There are substantial penalties for false claims. NAI Black may request additional information before removing any infringing material. NAI Black may provide the alleged infringing party with your e-mail address so that that person can respond to your allegations. NAI Black has registered a designated agent with the Copyright Office pursuant to 17 U.S.C. 512(c). If you believe your copyright material is being used on this Site without permission, please notify the designated agent as follows:

• By e-mail: MaryL@commercialms.com | Subject Line: Copyright Concern  
 • By mail: Commercial Brokers Association | Attn: DMCA Designated Agent | 12131 113<sup>th</sup> Ave NE Suite 101 | Kirkland, WA 98034  
 If e-mailing your copyright infringement notice, then NAI Black must receive the signed statement(s) mentioned above by mail, or attached to the e-mail, before we are required to take action.