

FOR LEASE

RETAIL PROPERTY



DUNBROOK CENTER

2720 Dundee Rd., Northbrook, IL 60062

BARRY J. MILLMAN

224.434.2731

bmillman@horizonrealtyservices.com

DUNBROOK CENTER

2720 DUNDEE RD., NORTHBROOK, IL 60062 // RETAIL PROPERTY FOR LEASE



OFFERING SUMMARY

Available SF: 830 - 2,070 SF

Lease Rate: \$20.00 SF/yr (NNN)

Building Size: 40,628 SF

Renovated: 2018

Zoning: Commercial

Submarket: North Suburban

Traffic Count: 25,200

PROPERTY OVERVIEW

This is a well known strong neighborhood center with deep roots in the community. The intersection boasts strong traffic counts, and easy access with multi-directional curb cuts.

LOCATION OVERVIEW

Spanning the Northeast corner of Dundee Rd. and Pfingston Rd. with storefronts facing both streets

AVAILABLE SPACES

SPACE	LEASE RATE	SIZE (SF)
2768 Dundee Rd.	Negotiable	1,421 SF
2768 Dundee Rd.	Negotiable	2,070 SF
2768 Dundee Rd.	Negotiable	2,070 SF
2750 Dundee Road	Negotiable	830 SF
755 Pfingston	\$20.00 SF/yr	1,047 SF

FOR MORE INFORMATION CONTACT:

BARRY J. MILLMAN
224.434.2731
bmillman@horizonrealtyservices.com

HORIZON REALTY SERVICES
1540 E. DUNDEE ROAD, SUITE 240, PALATINE, IL 60074
847.870.8585 // HORIZONREALTYSERVICES.COM

All information provided herein is from sources deemed reliable. No representation is made as to the accuracy thereof and it is submitted subject to its errors, omissions, changes, prior sale or lease or withdrawal without notice. Any projections, assumptions, and estimates, are presented as examples and may not represent actual performance. Recipients are encouraged to perform independent investigation of the property presented to their satisfaction.

DUNBROOK CENTER

2720 DUNDEE RD., NORTHBROOK, IL 60062 // RETAIL PROPERTY FOR LEASE

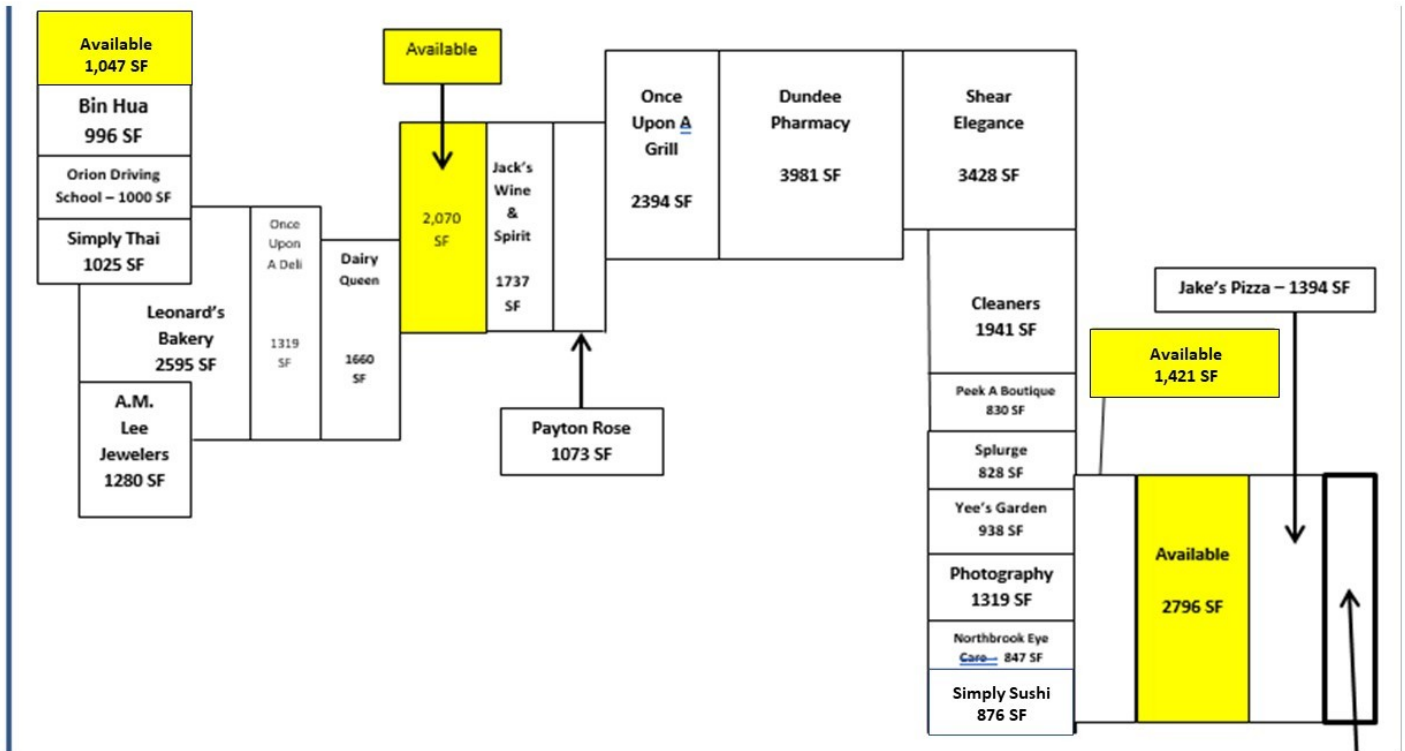

FOR MORE INFORMATION CONTACT:

BARRY J. MILLMAN
224.434.2731
bmillman@horizonrealtyservices.com

HORIZON REALTY SERVICES
1540 E. DUNDEE ROAD, SUITE 240, PALATINE, IL 60074
847.870.8585 // HORIZONREALTYSERVICES.COM

All information provided herein is from sources deemed reliable. No representation is made as to the accuracy thereof and it is submitted subject to its errors, omissions, changes, prior sale or lease or withdrawal without notice. Any projections, assumptions, and estimates, are presented as examples and may not represent actual performance. Recipients are encouraged to perform independent investigation of the property presented to their satisfaction.

DUNBROOK CENTER

2720 DUNDEE RD., NORTHBROOK, IL 60062 // RETAIL PROPERTY FOR LEASE

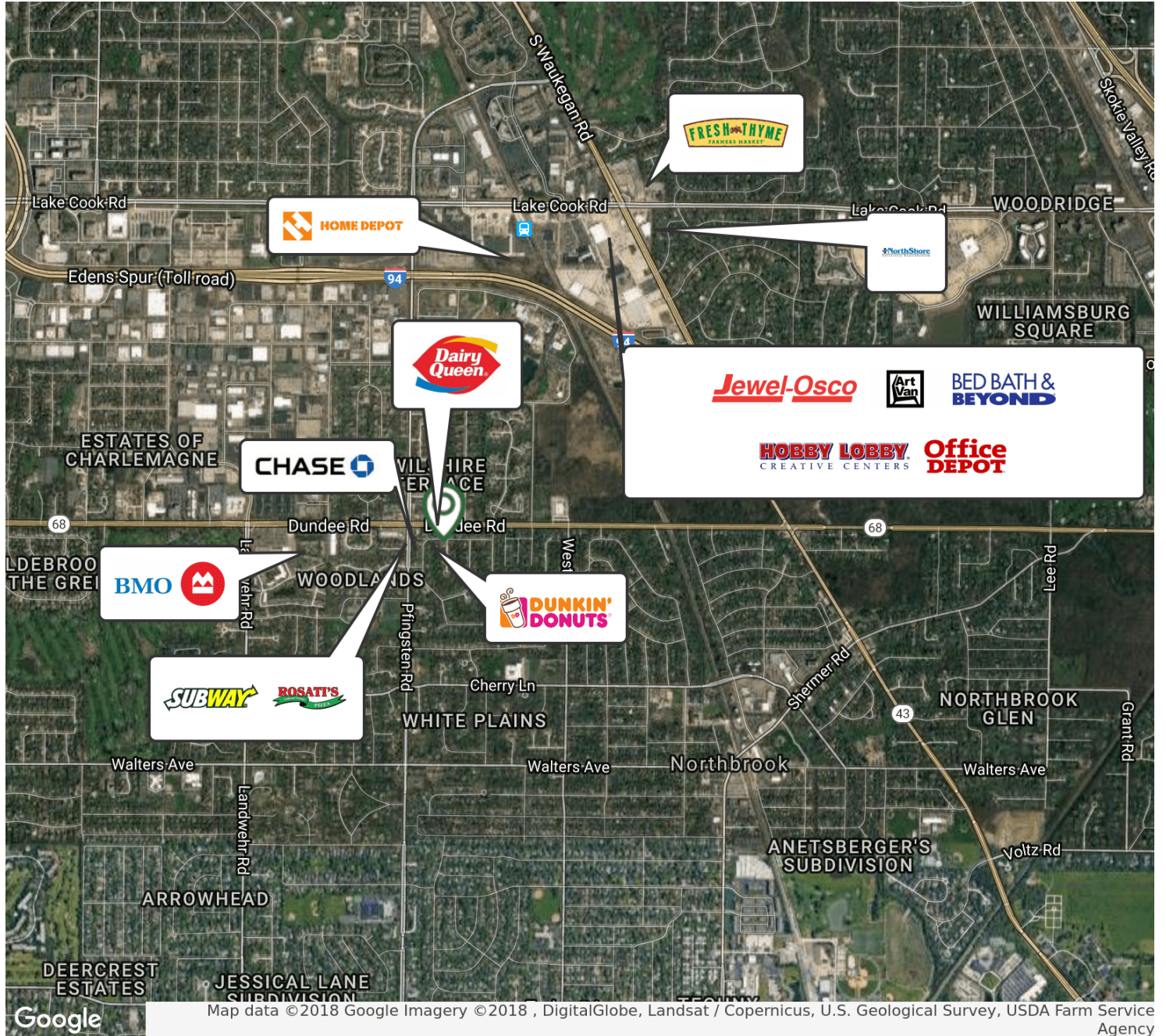

FOR MORE INFORMATION CONTACT:

BARRY J. MILLMAN
224.434.2731
bmillman@horizonrealtyservices.com

HORIZON REALTY SERVICES
1540 E. DUNDEE ROAD, SUITE 240, PALATINE, IL 60074
847.870.8585 // HORIZONREALTYSERVICES.COM

All information provided herein is from sources deemed reliable. No representation is made as to the accuracy thereof and it is submitted subject to its errors, omissions, changes, prior sale or lease or withdrawal without notice. Any projections, assumptions, and estimates, are presented as examples and may not represent actual performance. Recipients are encouraged to perform independent investigation of the property presented to their satisfaction.

DUNBROOK CENTER

2720 DUNDEE RD., NORTHBROOK, IL 60062 // RETAIL PROPERTY FOR LEASE



FOR MORE INFORMATION CONTACT:

BARRY J. MILLMAN
224.434.2731
bmillman@horizonrealtyservices.com

HORIZON REALTY SERVICES
1540 E. DUNDEE ROAD, SUITE 240, PALATINE, IL 60074
847.870.8585 // HORIZONREALTYSERVICES.COM

All information provided herein is from sources deemed reliable. No representation is made as to the accuracy thereof and it is submitted subject to its errors, omissions, changes, prior sale or lease or withdrawal without notice. Any projections, assumptions, and estimates, are presented as examples and may not represent actual performance. Recipients are encouraged to perform independent investigation of the property presented to their satisfaction.

DUNBROOK CENTER

2720 DUNDEE RD., NORTHBROOK, IL 60062 // RETAIL PROPERTY FOR LEASE

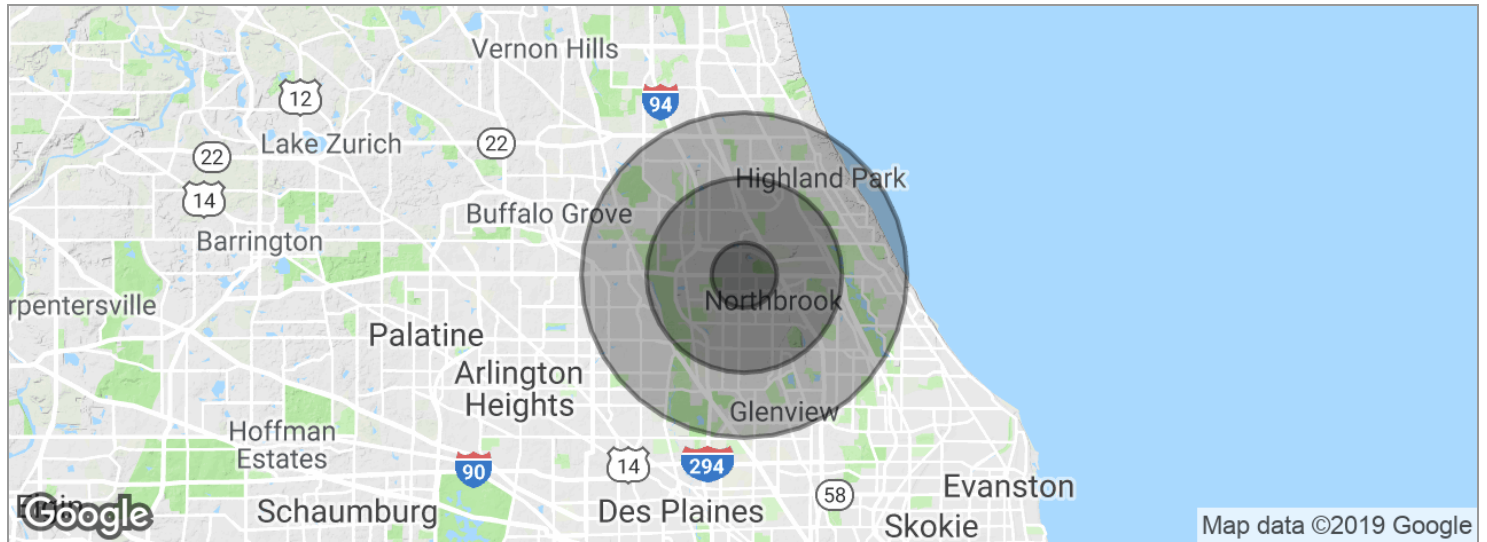

POPULATION	1 MILE	3 MILES	5 MILES
Total population	8,497	71,251	191,076
Median age	44.9	45.8	43.3
Median age (Male)	44.0	44.2	41.9
Median age (Female)	45.2	46.9	44.3
HOUSEHOLDS & INCOME	1 MILE	3 MILES	5 MILES
Total households	3,029	26,415	71,973
# of persons per HH	2.8	2.7	2.7
Average HH income	\$155,127	\$158,197	\$140,371
Average house value	\$585,960	\$610,211	\$571,856

* Demographic data derived from 2010 US Census

FOR MORE INFORMATION CONTACT:

BARRY J. MILLMAN
224.434.2731
bmillman@horizonrealtyservices.com

HORIZON REALTY SERVICES
1540 E. DUNDEE ROAD, SUITE 240, PALATINE, IL 60074
847.870.8585 // HORIZONREALTYSERVICES.COM

All information provided herein is from sources deemed reliable. No representation is made as to the accuracy thereof and it is submitted subject to its errors, omissions, changes, prior sale or lease or withdrawal without notice. Any projections, assumptions, and estimates, are presented as examples and may not represent actual performance. Recipients are encouraged to perform independent investigation of the property presented to their satisfaction.