



SECOND FLOOR RETAIL/OFFICE SPACE FOR LEASE

3,570 Sq. Ft.

Call for Rental Details

- Join Balducci's, Ulta, and Lexus
- On-Site Parking
- Beautiful, Updated Build Out
- Traffic Count:
Over 22,000 Vehicles/Day
- 18th Wealthiest Town in America
- Directly Across from
Luxury Gated Community,
Regents Park

FLOOR PLAN ON REVERSE SIDE

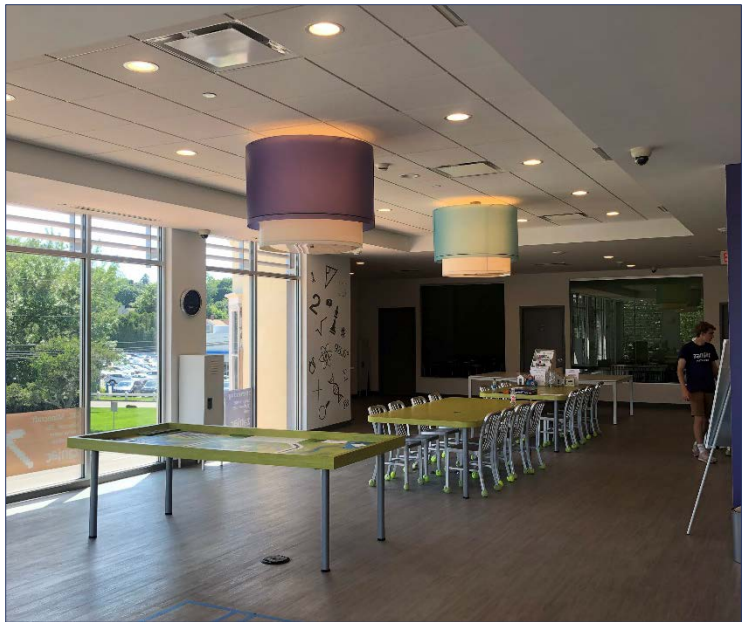

| By Drive Time | 5-Min | 10-Min | 15-Min |
|-------------------|-----------|-----------|-----------|
| Average HH Income | \$227,715 | \$227,808 | \$161,798 |
| Median HH Income | \$164,186 | \$163,068 | \$101,891 |
| Population | 8,321 | 38,405 | 128,003 |
| Total Households | 3,099 | 13,824 | 46,523 |
| Retail Potential | \$298M | \$1.4B | \$3.2B |

Call Owner's Exclusive Agent: Haryn Intner [914-779-8200](tel:914-779-8200) x123 haryn@admiralrealestate.com

Brokers
Protected

(Post Road East)

FLOOR PLAN

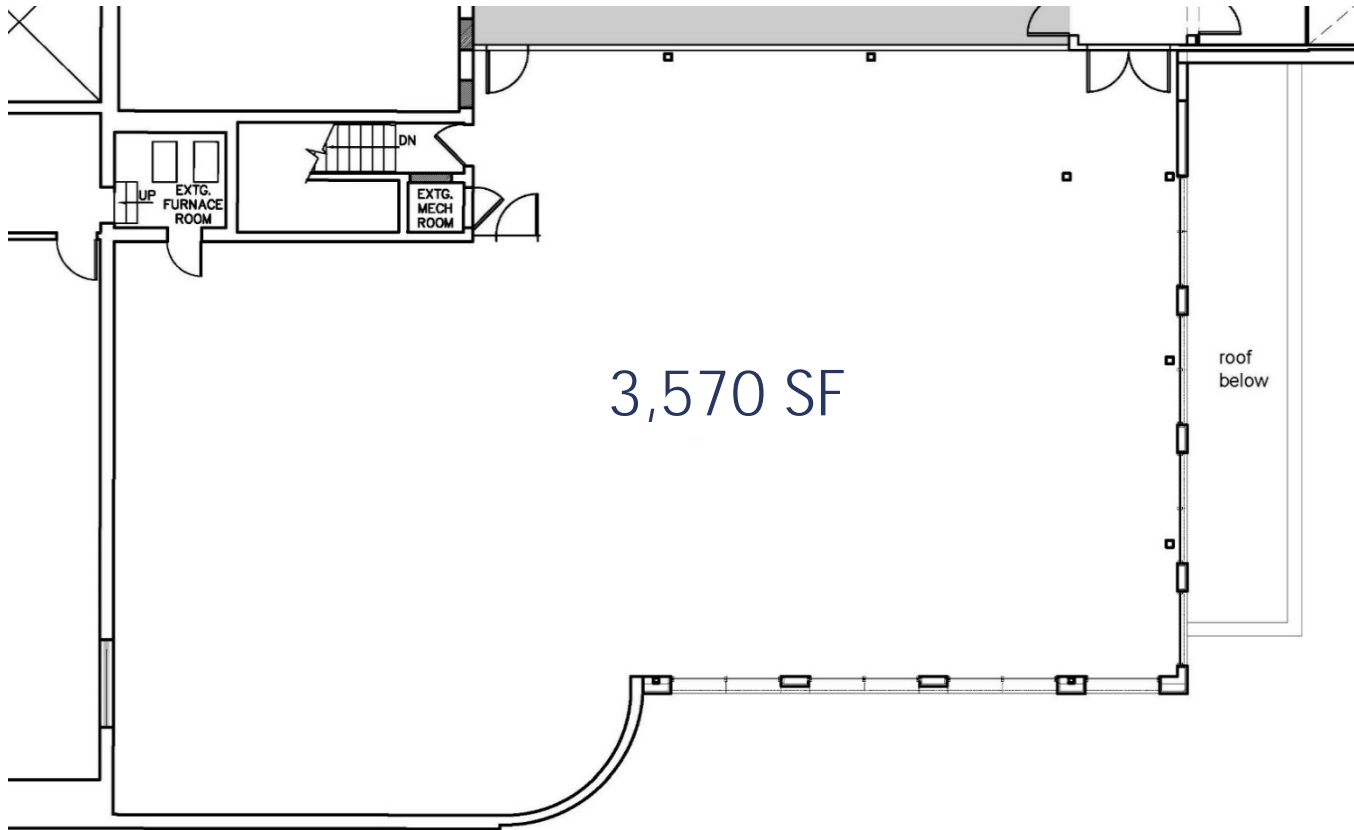
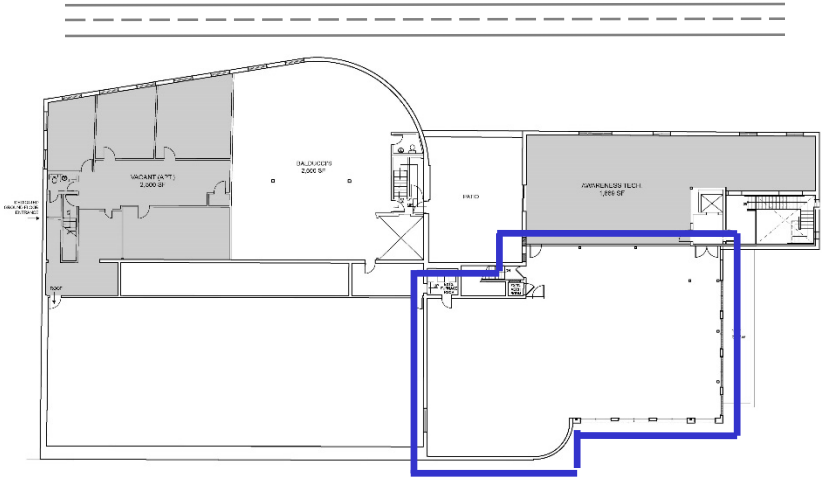

Call Owner's Exclusive Agent: Haryn Intner [914-779-8200](tel:914-779-8200) x123 haryn@admiralrealestate.com

Brokers
Protected