

Quiet Office Suite in Prime West Hollywood, CA

8344 Melrose Avenue, West Hollywood, CA 90069



RACHEL ADAMS (818) 697-9375
rachel@illicre.com · DRE#02052879

GREG OFFSAY (818) 697-9387
greg@illicre.com · DRE#01837719

ASHER PERGAMENT (818) 626-5770
asher@illicre.com · DRE#01922775

17547 Ventura Blvd., Ste. 304 · Encino CA 91316 · 818.501.2212/Phone · 818.501.2202/Fax · www.illicre.com · DRE #01834124

This information has been secured from sources we believe to be reliable, but we make no representations or warranties, expressed or implied, as to the accuracy of the information. References to square footage are approximate. References to neighboring retailers are subject to change, and may not be adjacent to the vacancy being marketed either prior to, during, or after leases are signed. Lessee must verify the information and bears all risk for any inaccuracies.

Quiet Office Suite in Prime West Hollywood, CA

8344 Melrose Avenue, West Hollywood, CA 90069

PROPERTY FEATURES

- Quiet office suite in highly desirable location on Melrose Avenue
- Approx. 285 - 675 SF Available
- Second floor walk up
- Shared restrooms on the second floor
- 2 parking spaces available
- Mel & Rose wine, spirits and gifts located on the first floor

AREA AMENITIES

- Located between La Cienega Blvd and Crescent Heights Blvd on Melrose Ave
- Surrounded by luxury shopping, dining and entertainment
- High pedestrian and vehicle traffic



DEMOS	1 Mile	3 Mile	5 Mile
Population	47,207	283,431	870,449
Avg. HH Income	\$122,141	\$121,048	\$104,037
Daytime Pop	40,924	238,675	721,309
Traffic Count	±31,874 cars per day		



RACHEL ADAMS (818) 697-9375

rachel@illicre.com · DRE#02052879

GREG OFFSAY (818) 697-9387

greg@illicre.com · DRE#01837719

ASHER PERGAMENT (818) 626-5770

asher@illicre.com · DRE#01922775

17547 Ventura Blvd., Ste. 304 · Encino CA 91316 · 818.501.2212/Phone · 818.501.2202/Fax · www.illicre.com · DRE #01834124

This information has been secured from sources we believe to be reliable, but we make no representations or warranties, expressed or implied, as to the accuracy of the information. References to square footage are approximate. References to neighboring retailers are subject to change, and may not be adjacent to the vacancy being marketed either prior to, during, or after leases are signed. Lessee must verify the information and bears all risk for any inaccuracies.

Quiet Office Suite in Prime West Hollywood, CA

8344 Melrose Avenue, West Hollywood, CA 90069



RACHEL ADAMS (818) 697-9375
rachel@illicre.com · DRE#02052879

GREG OFFSAY (818) 697-9387
greg@illicre.com · DRE#01837719

ASHER PERGAMENT (818) 626-5770
asher@illicre.com · DRE#01922775

17547 Ventura Blvd., Ste. 304 · Encino CA 91316 · 818.501.2212/Phone · 818.501.2202/Fax · www.illicre.com · DRE #01834124

This information has been secured from sources we believe to be reliable, but we make no representations or warranties, expressed or implied, as to the accuracy of the information. References to square footage are approximate. References to neighboring retailers are subject to change, and may not be adjacent to the vacancy being marketed either prior to, during, or after leases are signed. Lessee must verify the information and bears all risk for any inaccuracies.

Quiet Office Suite in Prime West Hollywood, CA

8344 Melrose Avenue, West Hollywood, CA 90069



RACHEL ADAMS (818) 697-9375

rachel@illicre.com · DRE#02052879

GREG OFFSAY (818) 697-9387

greg@illicre.com · DRE#01837719

ASHER PERGAMENT (818) 626-5770

asher@illicre.com · DRE#01922775

17547 Ventura Blvd., Ste. 304 · Encino CA 91316 · 818.501.2212/Phone · 818.501.2202/Fax · www.illicre.com · DRE #01834124

This information has been secured from sources we believe to be reliable, but we make no representations or warranties, expressed or implied, as to the accuracy of the information. References to square footage are approximate. References to neighboring retailers are subject to change, and may not be adjacent to the vacancy being marketed either prior to, during, or after leases are signed. Lessee must verify the information and bears all risk for any inaccuracies.

Quiet Office Suite in Prime West Hollywood, CA

8344 Melrose Avenue, West Hollywood, CA 90069

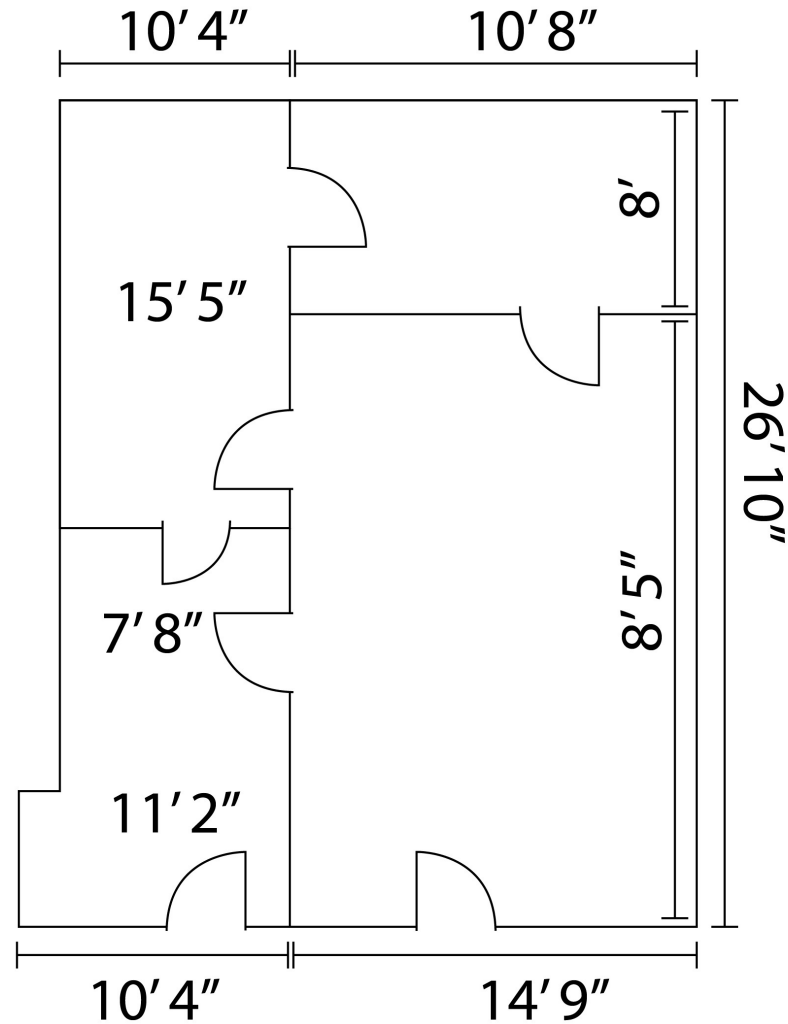

COMMERCIAL
REAL ESTATE

RACHEL ADAMS (818) 697-9375

rachel@illicre.com · DRE#02052879

GREG OFFSAY (818) 697-9387

greg@illicre.com · DRE#01837719

ASHER PERGAMENT (818) 626-5770

asher@illicre.com · DRE#01922775

17547 Ventura Blvd., Ste. 304 · Encino CA 91316 · 818.501.2212/Phone · 818.501.2202/Fax · www.illicre.com · DRE #01834124

This information has been secured from sources we believe to be reliable, but we make no representations or warranties, expressed or implied, as to the accuracy of the information. References to square footage are approximate. References to neighboring retailers are subject to change, and may not be adjacent to the vacancy being marketed either prior to, during, or after leases are signed. Lessee must verify the information and bears all risk for any inaccuracies.

Quiet Office Suite in Prime West Hollywood, CA

8344 Melrose Avenue, West Hollywood, CA 90069



RACHEL ADAMS (818) 697-9375
rachel@illicre.com · DRE#02052879

GREG OFFSAY (818) 697-9387
greg@illicre.com · DRE#01837719

ASHER PERGAMENT (818) 626-5770
asher@illicre.com · DRE#01922775

17547 Ventura Blvd., Ste. 304 · Encino CA 91316 · 818.501.2212/Phone · 818.501.2202/Fax · www.illicre.com · DRE #01834124

This information has been secured from sources we believe to be reliable, but we make no representations or warranties, expressed or implied, as to the accuracy of the information. References to square footage are approximate. References to neighboring retailers are subject to change, and may not be adjacent to the vacancy being marketed either prior to, during, or after leases are signed. Lessee must verify the information and bears all risk for any inaccuracies.