

**For Lease**  
**7325 Friendly Ave, Suite C**  
**Greensboro, NC 27408**

**General Information**

<b>Address</b>	<b>7325 Friendly Ave Suite C</b>
<b>Total S.F.</b>	<b>1265</b>
<b>Lease Price</b>	<b>\$1361 / month</b>
<b>Building Type</b>	<b>Office / Medical</b>
<b>Year Built</b>	<b>1985</b>
<b>Bathrooms</b>	<b>2</b>
<b>Offices</b>	<b>4</b>
<b>Other Space</b>	<b>Kitchenette</b>



**A 1,265 SF office space located at Stoneleigh Business Park on W. Friendly Avenue, conveniently located near the airport. Ample parking. A full service building (excluding janitorial) leasing for \$1,361 per month, This office has 2 restrooms, break area, 4 offices and opens up to a courtyard. This office park is the home of the world famous Wall Street Deli! Available December 1st!**



**Bonnie Rimmer, Broker**

**Chris Matthews, Broker**

**Office: 336-617-0542**

**Mobile: 336-420-7365**

**Fax: 336-617-0544**



# Ground Floor

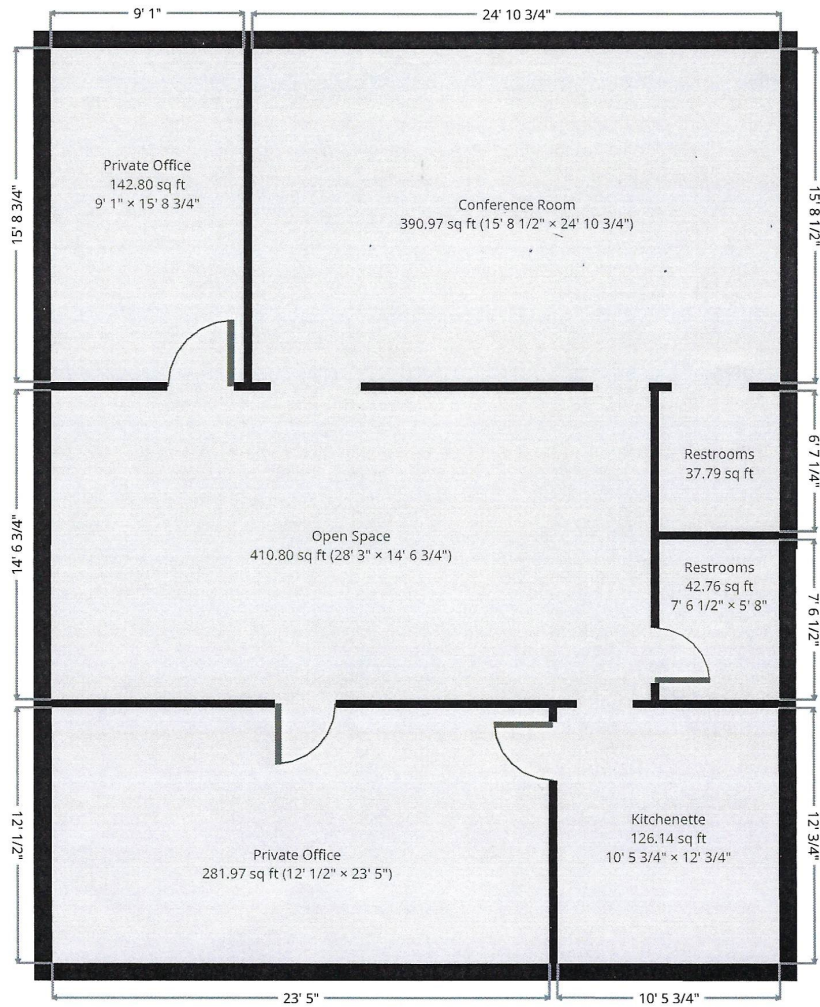

THIS FLOORPLAN IS PROVIDED WITHOUT WARRANTY OF ANY KIND. SENSOPIA DISCLAIMS ANY WARRANTY INCLUDING, WITHOUT LIMITATION, SATISFACTORY QUALITY OR ACCURACY OF DIMENSIONS.



# Plan 13

## Private Office

Width: 12' 1/2"  
 Length: 23' 5"  
 Area: 281.97 sq ft  
 Perimeter: 70' 11"  
 Ceiling Height: 10' 6 3/4"

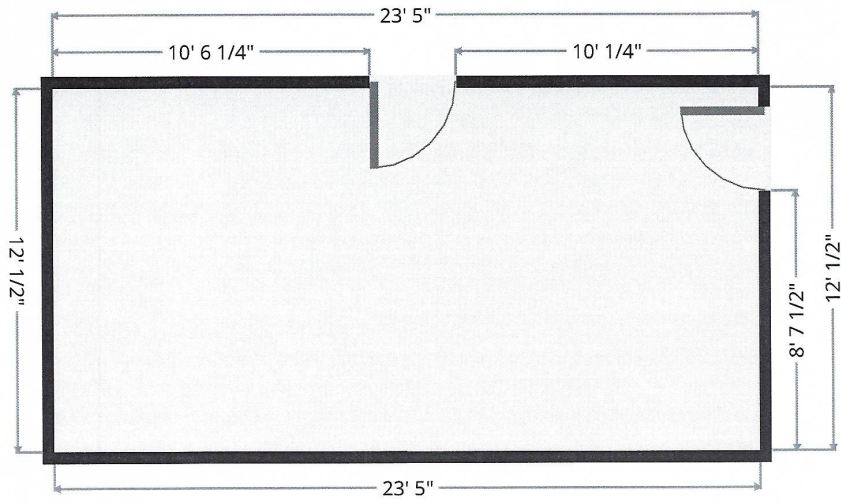
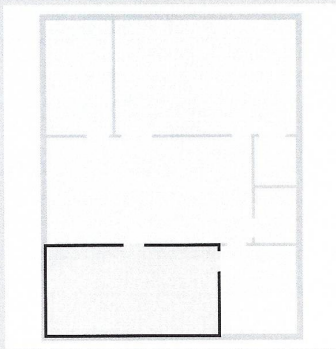

## Kitchenette

Width: 10' 5 3/4"  
 Length: 12' 3/4"  
 Area: 126.14 sq ft  
 Perimeter: 45' 1/2"  
 Ceiling Height: 10' 6 3/4"

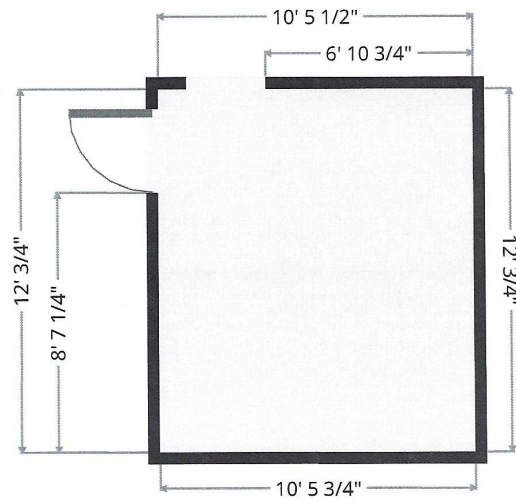
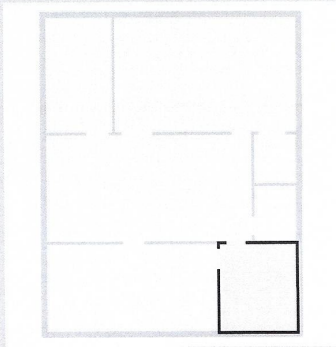

THIS FLOORPLAN IS PROVIDED WITHOUT WARRANTY OF ANY KIND. SENSOPIA DISCLAIMS ANY WARRANTY INCLUDING, WITHOUT LIMITATION, SATISFACTORY QUALITY OR ACCURACY OF DIMENSIONS.

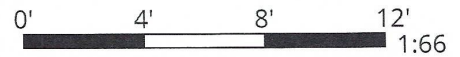

# Plan 13

## Restrooms

Width: 5' 8"  
 Length: 7' 6 1/2"  
 Area: 42.76 sq ft  
 Perimeter: 26' 5"  
 Ceiling Height: 10' 6 3/4"

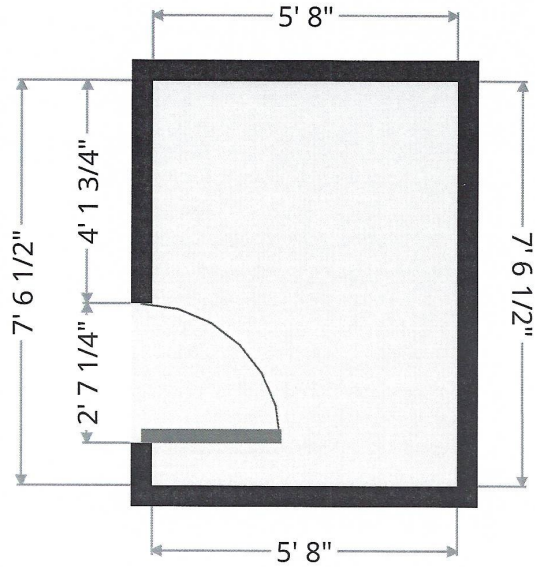
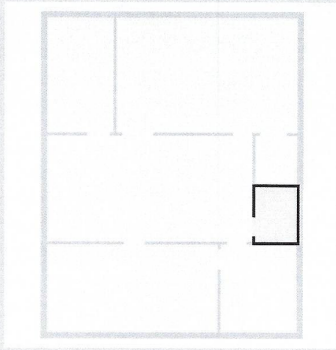

## Restrooms

Width: 5' 8 1/2"  
 Length: 6' 7 1/4"  
 Area: 37.79 sq ft  
 Perimeter: 24' 7 3/4"  
 Ceiling Height: 10' 6 3/4"

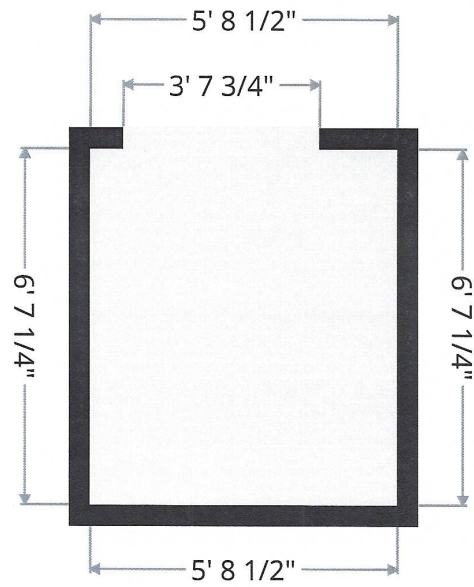
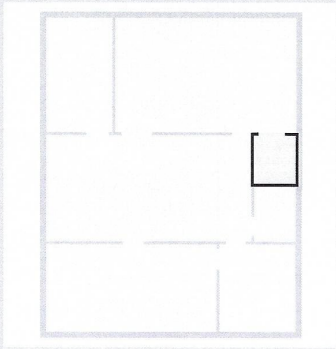

THIS FLOORPLAN IS PROVIDED WITHOUT WARRANTY OF ANY KIND. SENSOPIA DISCLAIMS ANY WARRANTY INCLUDING, WITHOUT LIMITATION, SATISFACTORY QUALITY OR ACCURACY OF DIMENSIONS.

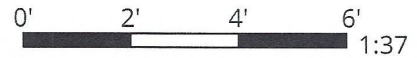

# Plan 13

## Conference Room

Width: 15' 8 1/2"  
 Length: 24' 10 3/4"  
 Area: 390.97 sq ft  
 Perimeter: 81' 2 1/2"  
 Ceiling Height: 10' 6 3/4"

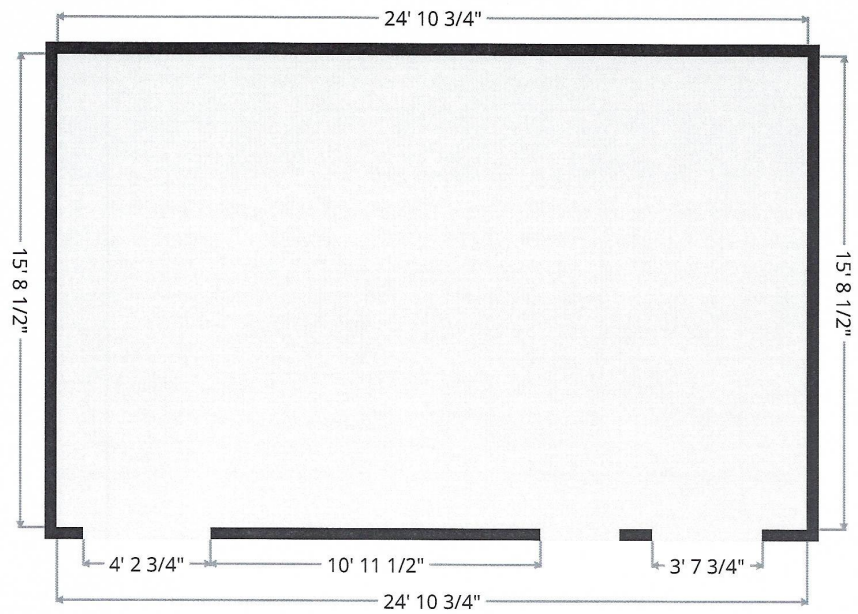
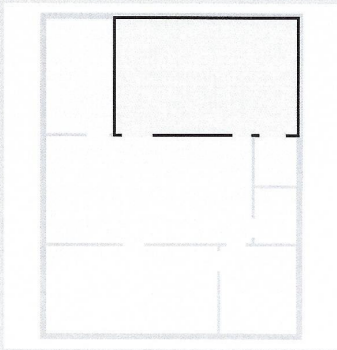

## Private Office

Width: 9' 1"  
 Length: 15' 8 3/4"  
 Area: 142.80 sq ft  
 Perimeter: 49' 7 1/4"  
 Ceiling Height: 10' 6 3/4"

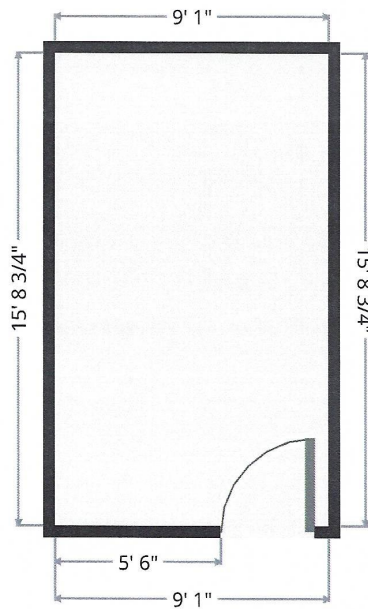
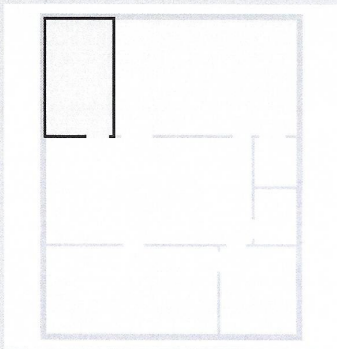

THIS FLOORPLAN IS PROVIDED WITHOUT WARRANTY OF ANY KIND. SENSOPIA DISCLAIMS ANY WARRANTY INCLUDING, WITHOUT LIMITATION, SATISFACTORY QUALITY OR ACCURACY OF DIMENSIONS.

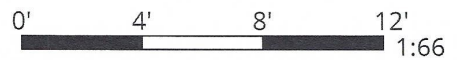

# Plan 13

## Open Space

Width: 14' 6 3/4"  
 Length: 28' 3"  
 Area: 410.80 sq ft  
 Perimeter: 85' 6 3/4"

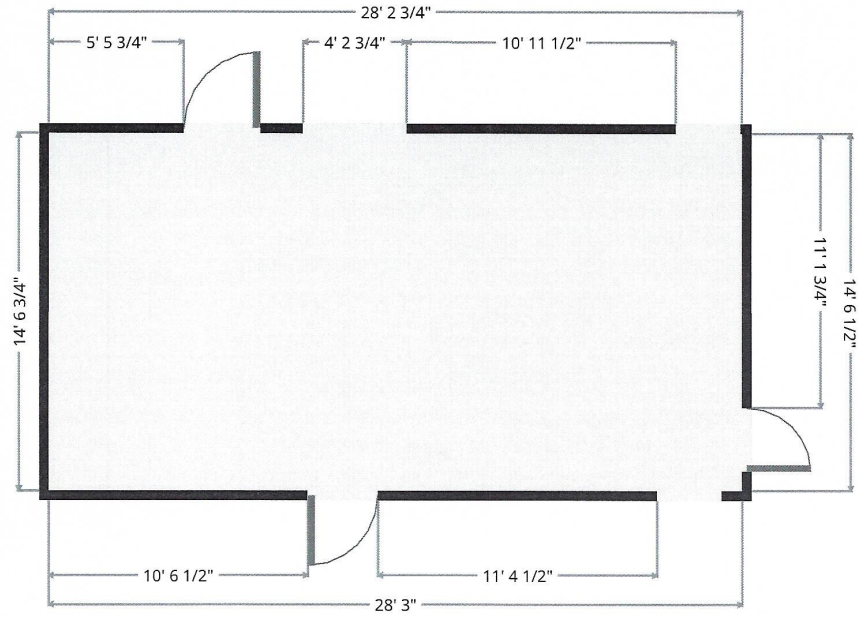
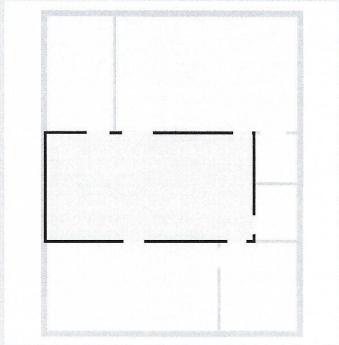

THIS FLOORPLAN IS PROVIDED WITHOUT WARRANTY OF ANY KIND. SENSOPIA DISCLAIMS ANY WARRANTY INCLUDING, WITHOUT LIMITATION, SATISFACTORY QUALITY OR ACCURACY OF DIMENSIONS.

