

SANTOMAS

COMMERCE PARK

Santa Clara, California



MIKE BAKER | +1 408 615 3406 | mike.baker@cushwake.com | LIC #01884037

WALT STEPHENSON | +1 408 615 3458 | walt.stephenson@cushwake.com | LIC #01793438



LINK
INDUSTRIAL



**CUSHMAN &
WAKEFIELD**

Cushman & Wakefield Copyright 2020. No warranty or representation, express or implied, is made to the accuracy or completeness of the information contained herein, and same is submitted subject to errors, omissions, change of price, rental or other conditions, withdrawal without notice, and to any special listing conditions imposed by the property owner(s). As applicable, we make no representation as to the condition of the property (or properties) in question.

SANTOMAS COMMERCE PARK

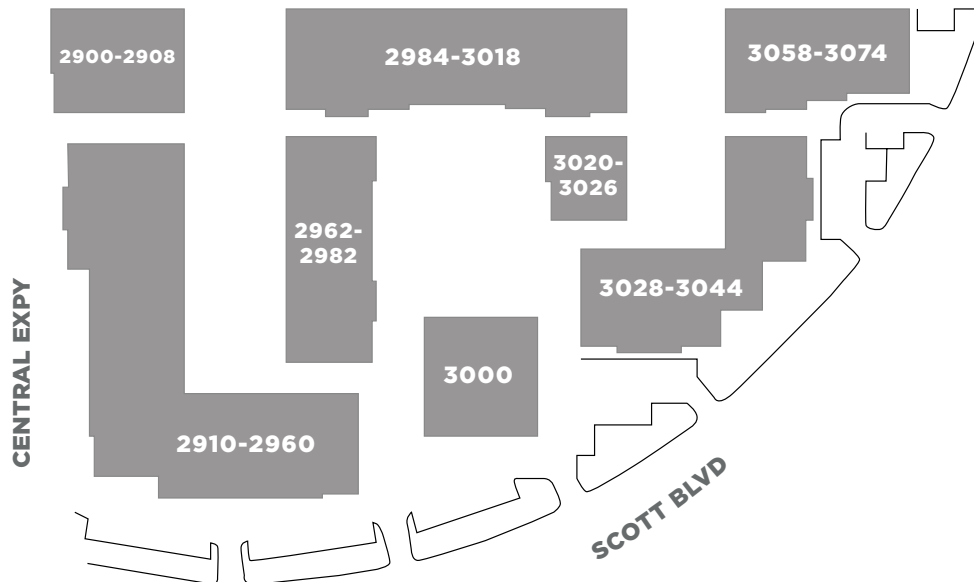

HIGHLIGHTS

- Multi-Tenant Office, R&D and Industrial Business Park
- Excellent Santa Clara Location on Scott Boulevard and Central Expressway
- Suite Sizes Range from ± 545 SF to $\pm 5,062$ SF
- Move-In Ready Suites Available for Immediate Occupancy
- On-Site Restaurant and Property Management
- Flexible Layouts Include a Combination of Office, Lab and Warehouse
- Grade Level Loading
- AT&T, WiLine and BIRCH Internet Service Available
- Low Electrical Costs Through Silicon Valley Power
- 2.5/1,000 Parking Ratio

AVAILABILITY

ADDRESS	RSF	COMMENTS
3000 Scott Blvd, Ste. 201	545 SF	100% Office
3000 Scott Blvd, Ste. 116	594 SF	100% Office
3000 Scott Blvd, Ste. 108	674 SF	100% Office
3028-B Scott Blvd	820 SF	100% Office
3000 Scott Blvd, Ste. 204	1,165 SF	100% Office
3000 Scott Blvd, Ste. 216	1,346 SF	100% Office
3048 Scott Blvd	1,640 SF	30% Office / 30% Warehouse / 40% Lab
2962 Scott Blvd	1,680 SF	60% Office / 30% Lab / 10% Warehouse
3050 Scott Blvd	1,740 SF	40% Office / 60% Warehouse
2968 Scott Blvd	1,780 SF	50% Office / 25% Lab / 25% Warehouse
2980 Scott Blvd	1,780 SF	60% Office / 30% Lab / 10% Warehouse
2970 Scott Blvd	1,820 SF	20% Office / 60% Lab / 20% Warehouse
2972 Scott Blvd	1,820 SF	45% Office / 40% Lab / 15% Warehouse
2982 Scott Blvd	1,830 SF	75% Office / 10% Lab / 15% Warehouse
2958 Scott Blvd	1,918 SF	40% Office / 60% Warehouse
2960 Scott Blvd	1,918 SF	50% Office / 50% Warehouse
3016 Scott Blvd	1,940 SF	50% Office / 15% Lab / 35% Warehouse
2996 Scott Blvd	1,980 SF	50% Office / 25% Lab / 25% Warehouse
3032 Scott Blvd	2,030 SF	40% Office / 10% Lab / 50% Warehouse
3012 Scott Blvd	2,060 SF	40% Office / 60% Warehouse
3006 Scott Blvd	2,063 SF	
3000 Scott Blvd, Ste. 112 & 115	2,314 SF	100% Office
2942-2944 Scott Blvd	4,040 SF	30% Office / 10% Lab / 60% Warehouse
3034-3036 Scott Blvd	4,110 SF	30% Office / 40% Lab / 30% Warehouse
2928-2932 Scott Blvd	6,180 SF	
2910-2916 Scott Blvd	9,559 SF	

UPDATED: DECEMBER 2020



SITE PLAN

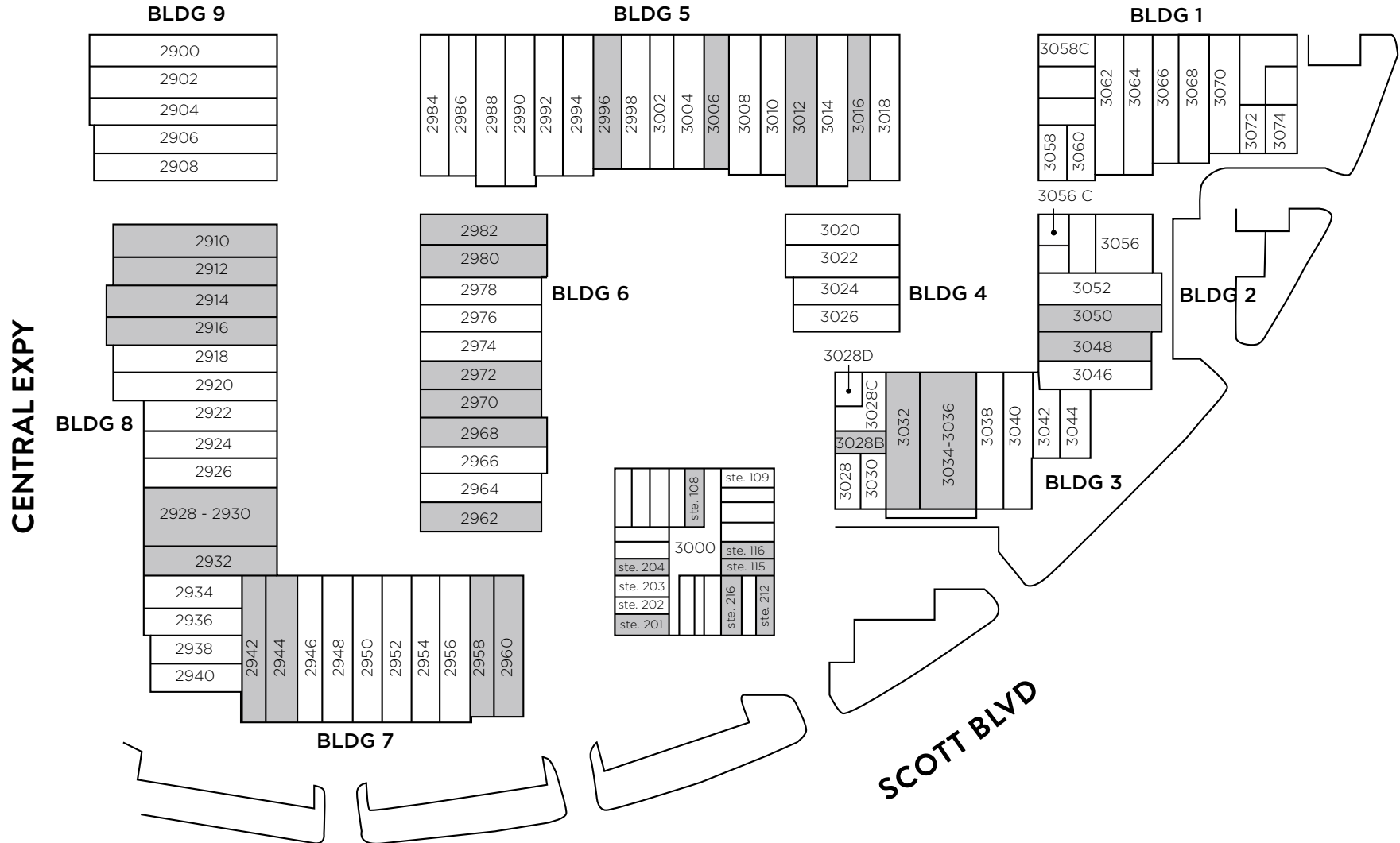

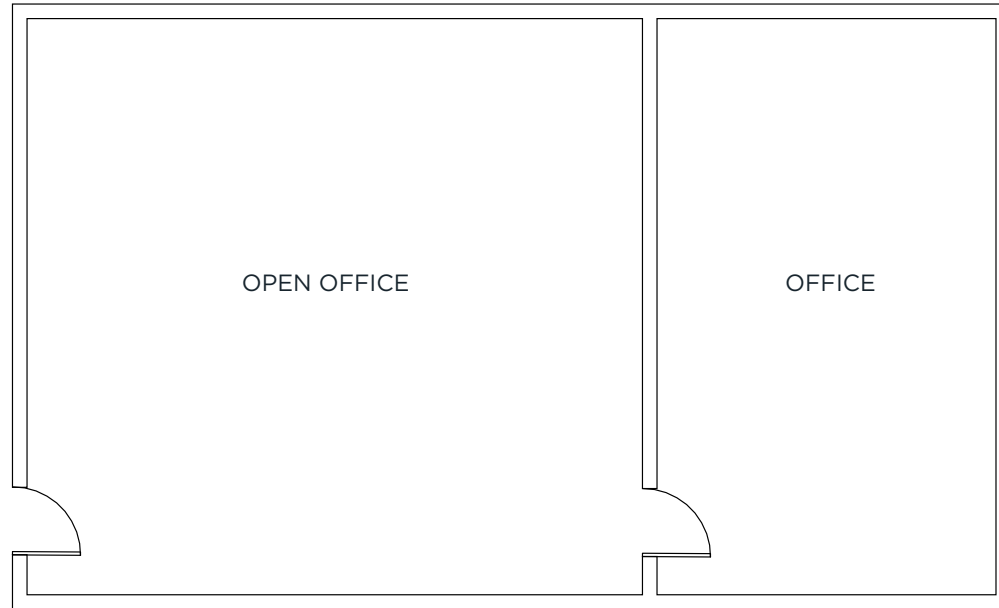

■ WAREHOUSE
▨ VCT / DROPPED CEILING

3000 SCOTT BOULEVARD, SUITE 201 | ±545 SF

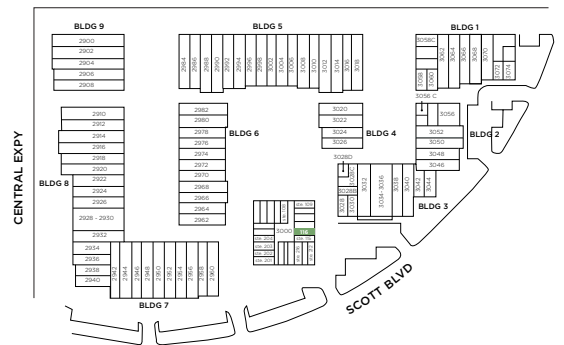
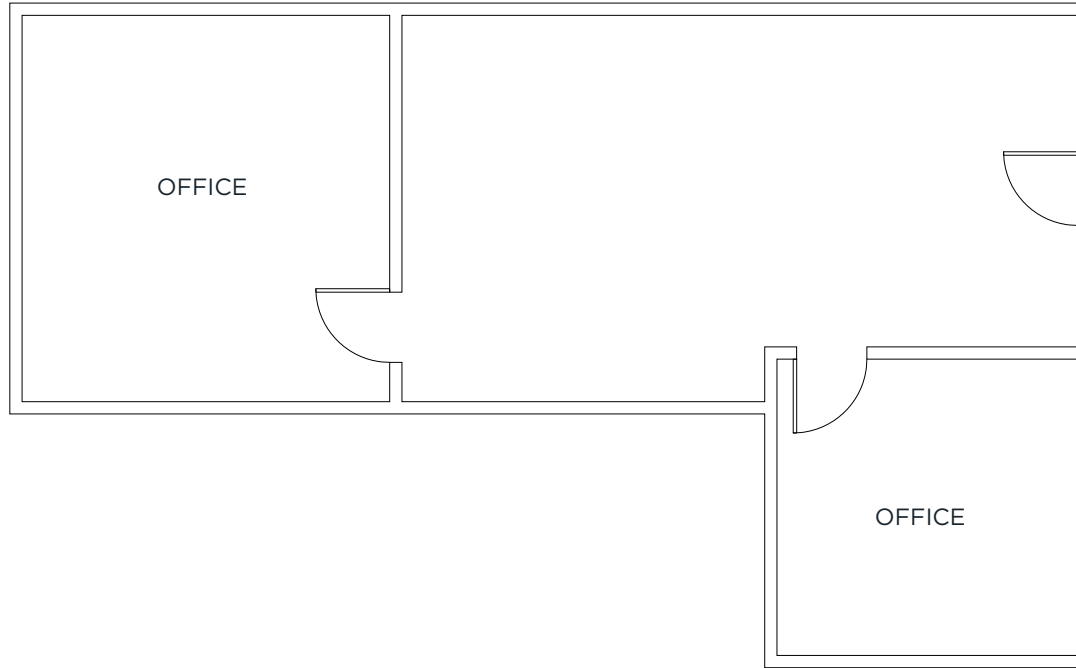

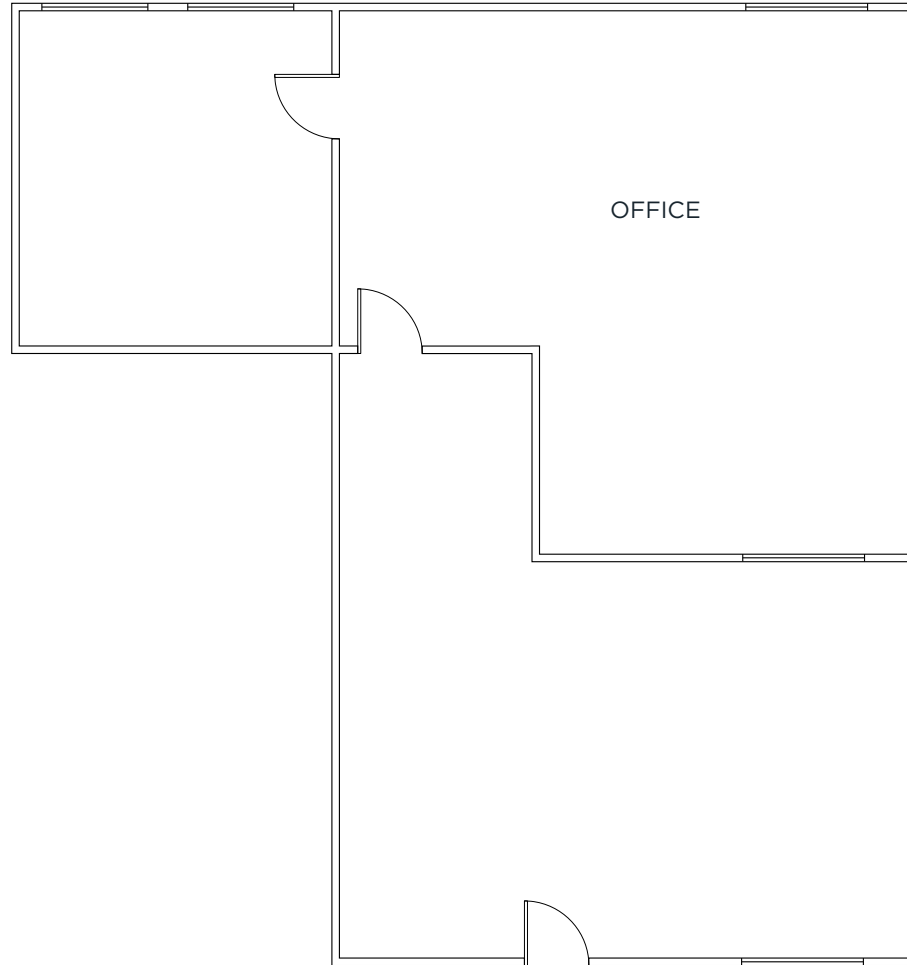

3000 SCOTT BOULEVARD, SUITE 108 | ±647 SF

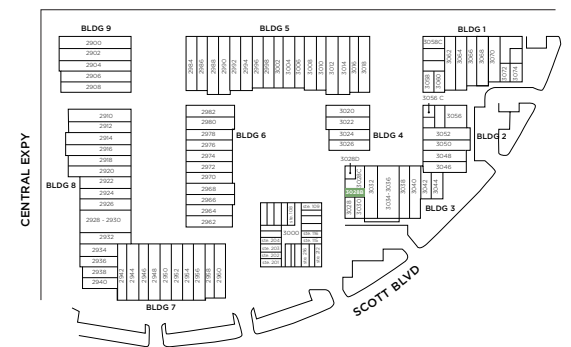
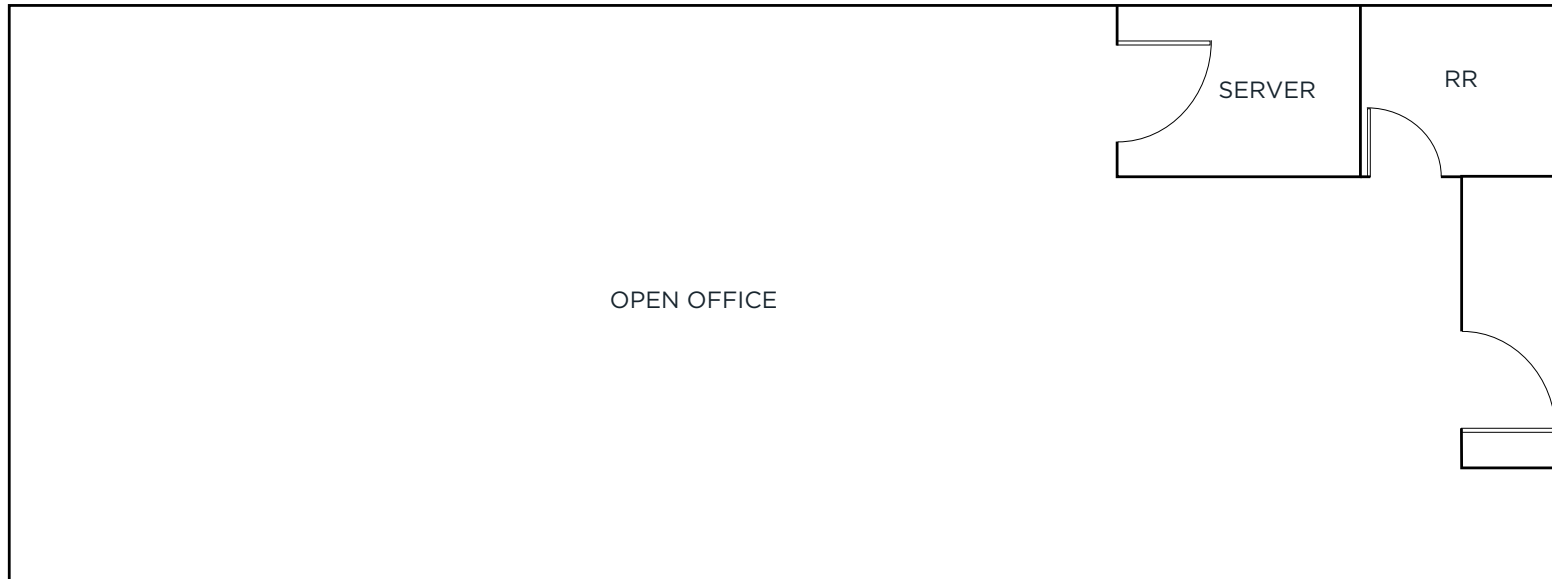

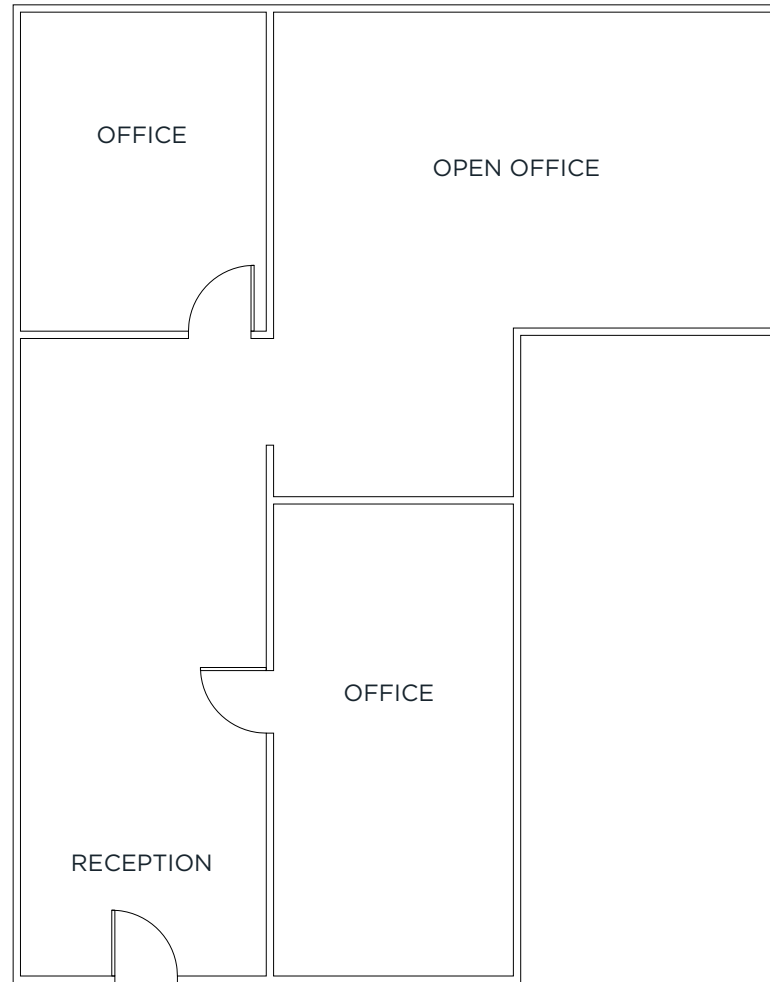

WAREHOUSE
 VCT / DROPPED CEILING

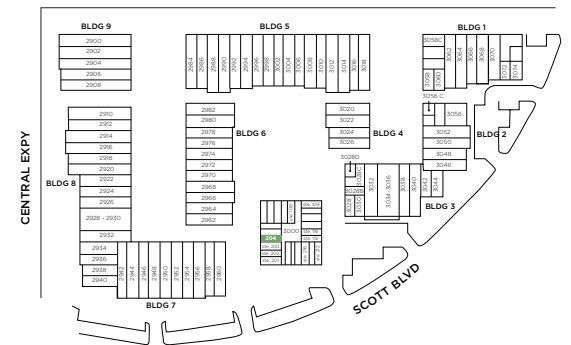

3000 SCOTT BOULEVARD, SUITE 204 | ±1,165 SF

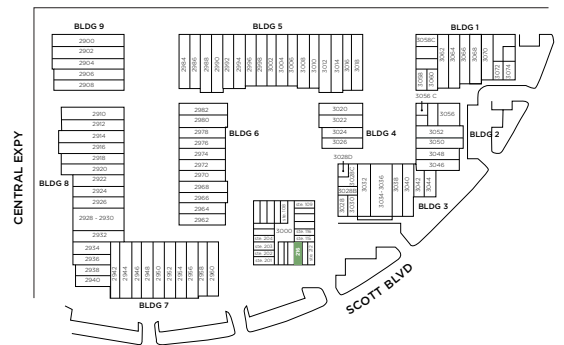
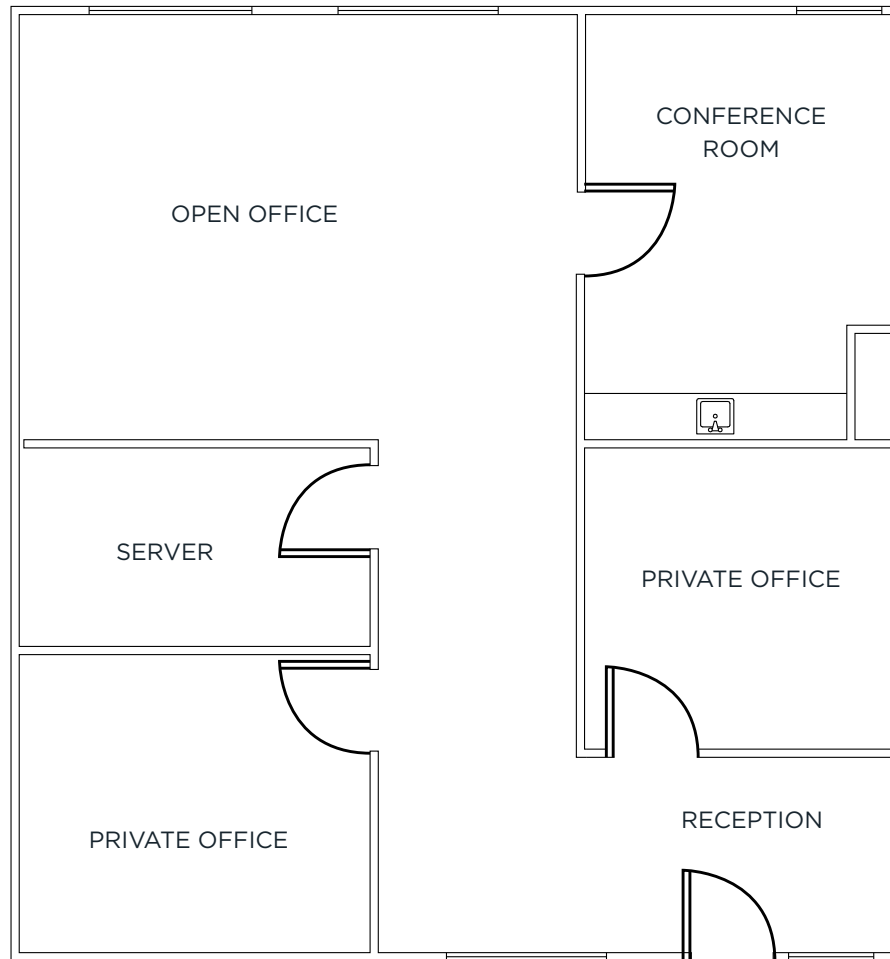

3000 SCOTT BOULEVARD, SUITE 216 | ±1,346 SF

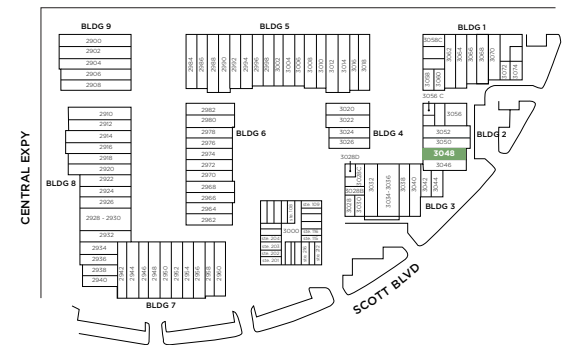

3048 SCOTT BOULEVARD | ±1,640 SF

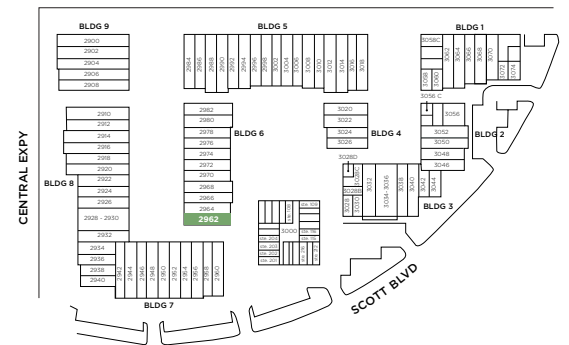
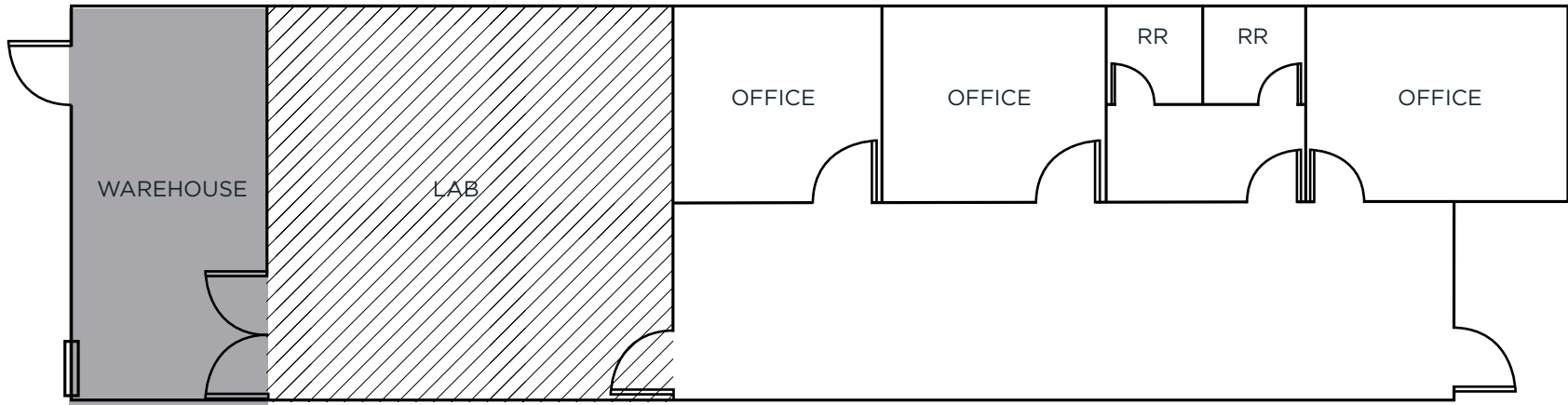

2962 SCOTT BOULEVARD | ±1,680 SF

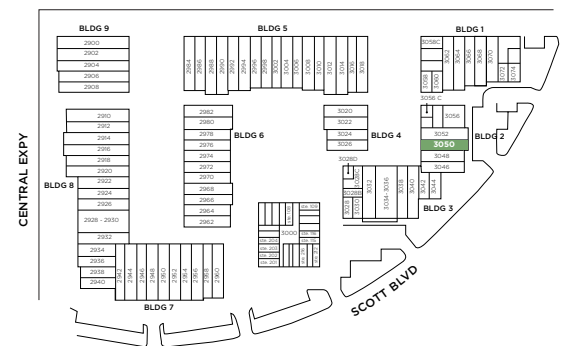
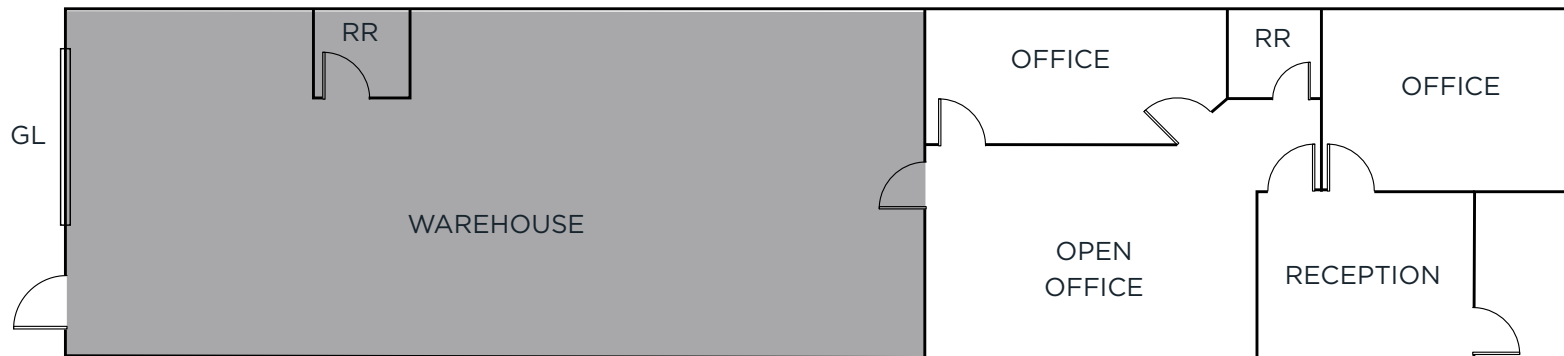

3050 SCOTT BOULEVARD | ±1,740 SF

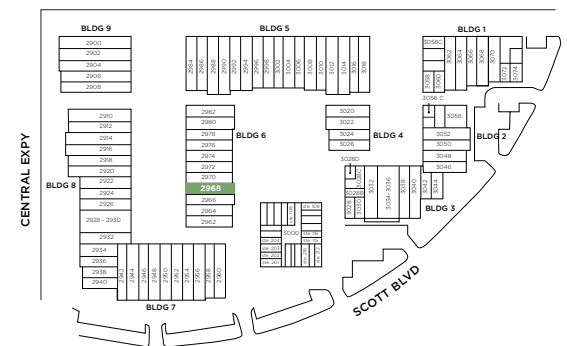
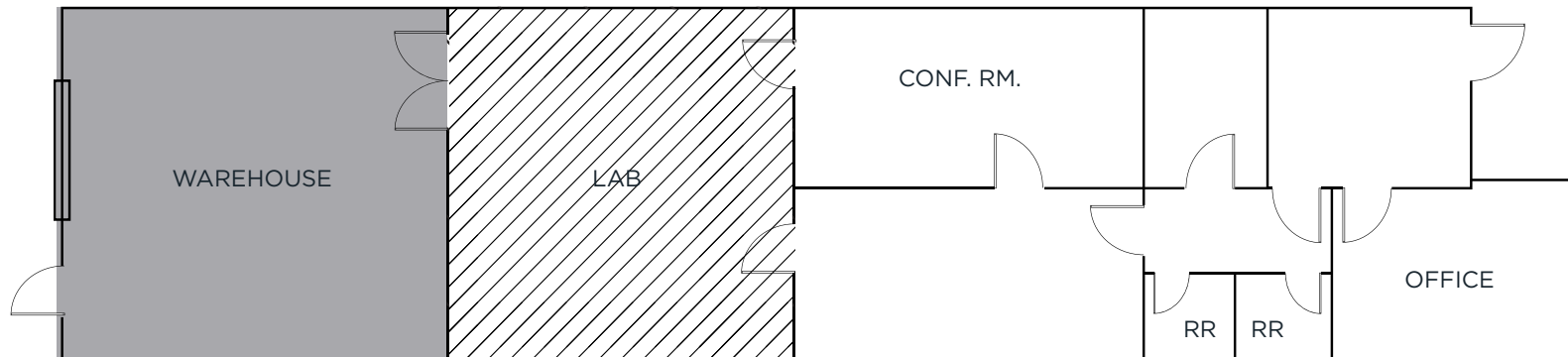

2968 SCOTT BOULEVARD | ±1,780 SF

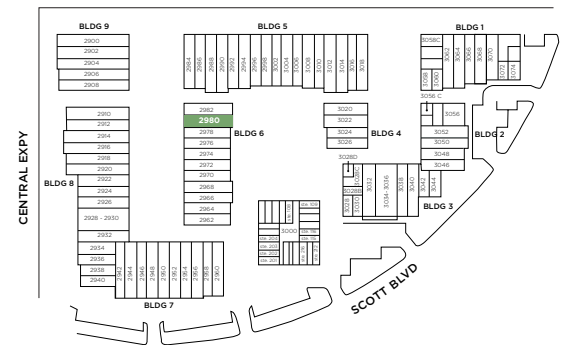
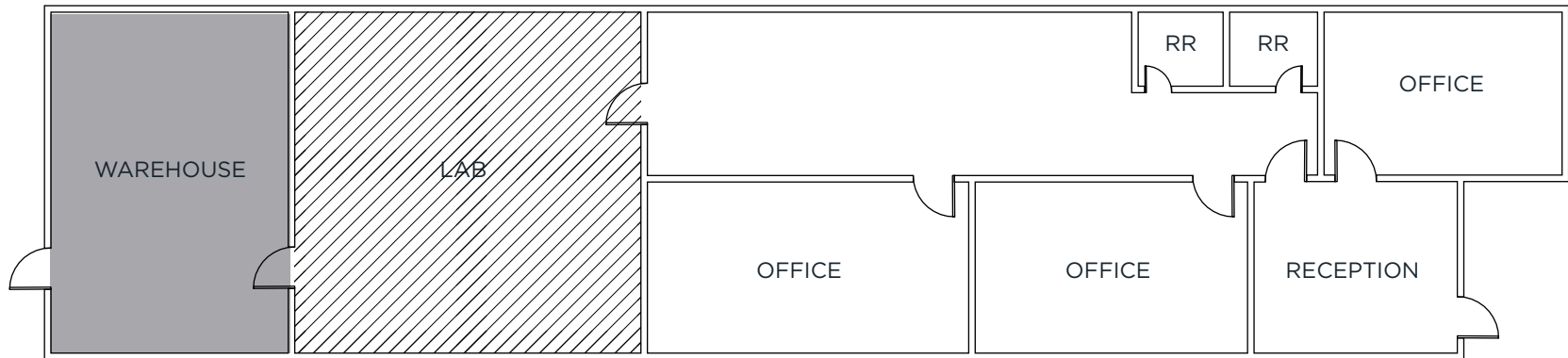

2980 SCOTT BOULEVARD | ±1,780 SF

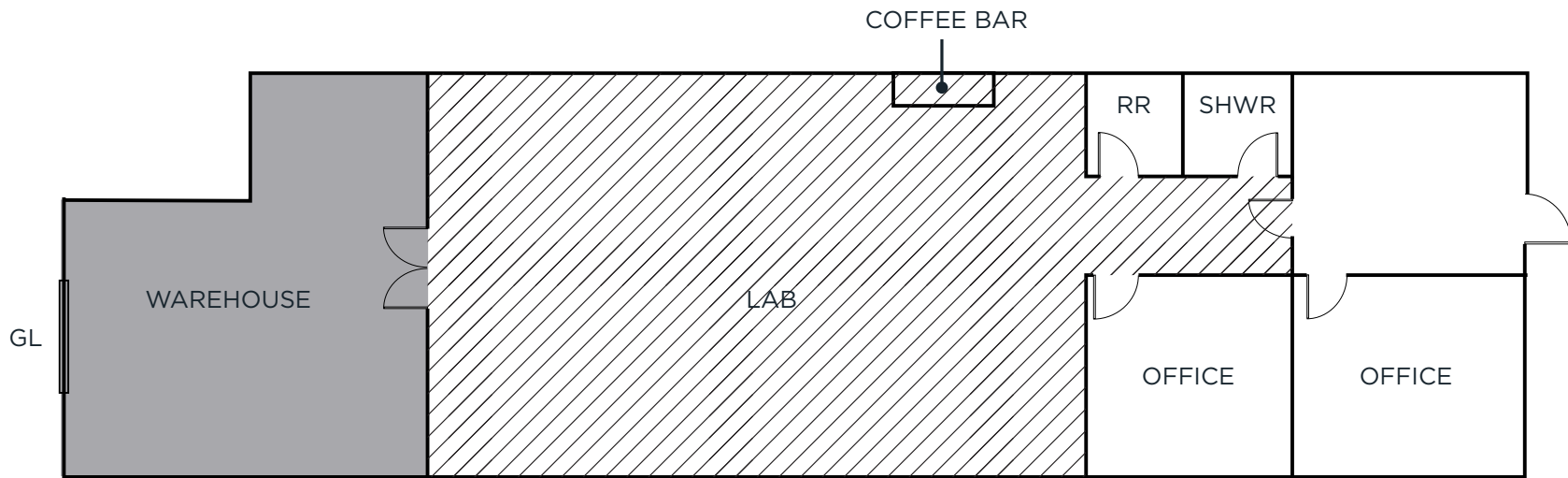

2970 SCOTT BOULEVARD | ±1,820 SF

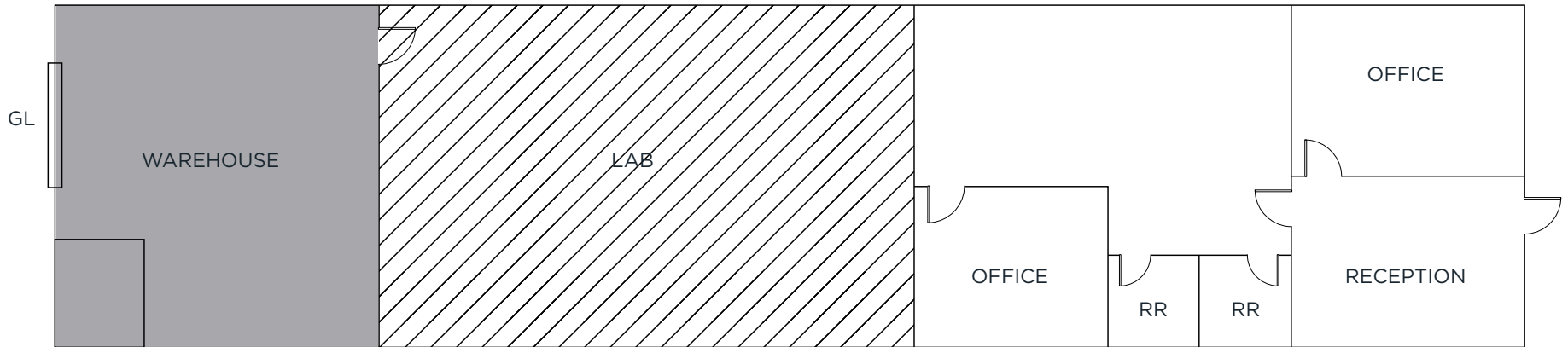

2972 SCOTT BOULEVARD | ±1,820 SF

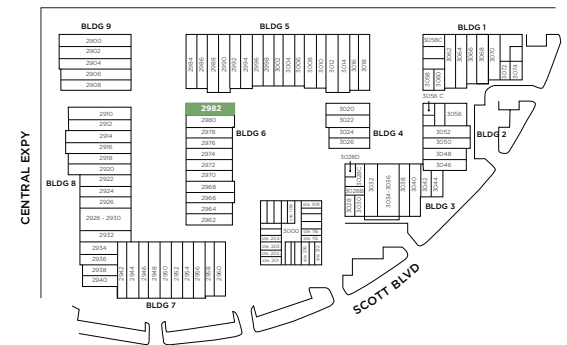
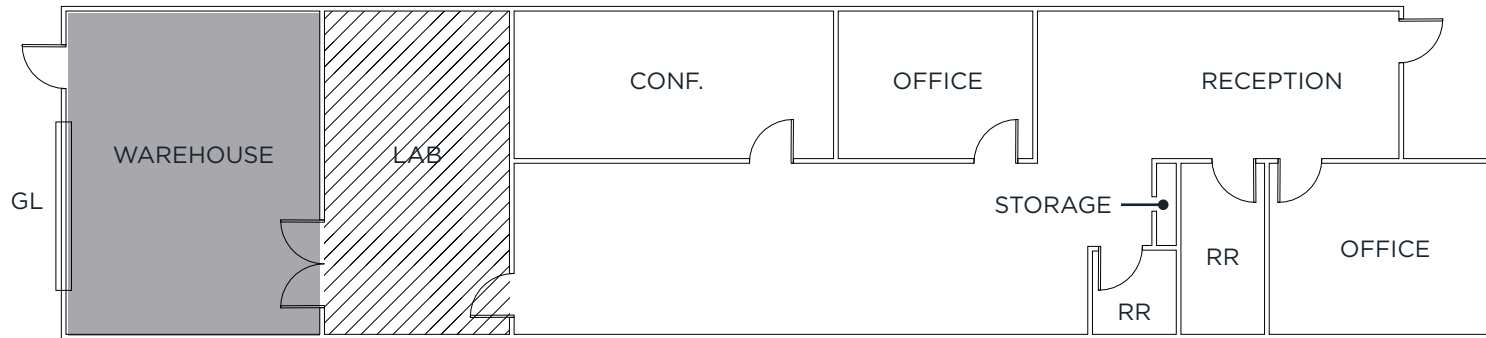

2982 SCOTT BOULEVARD | ±1,830 SF

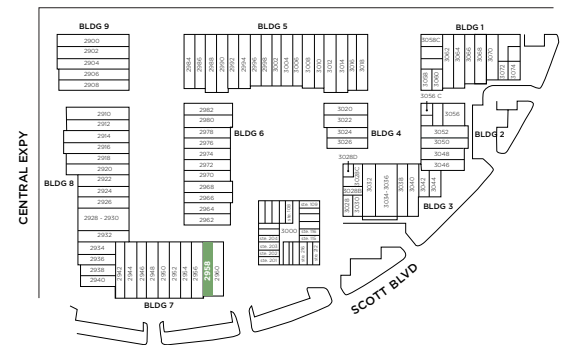
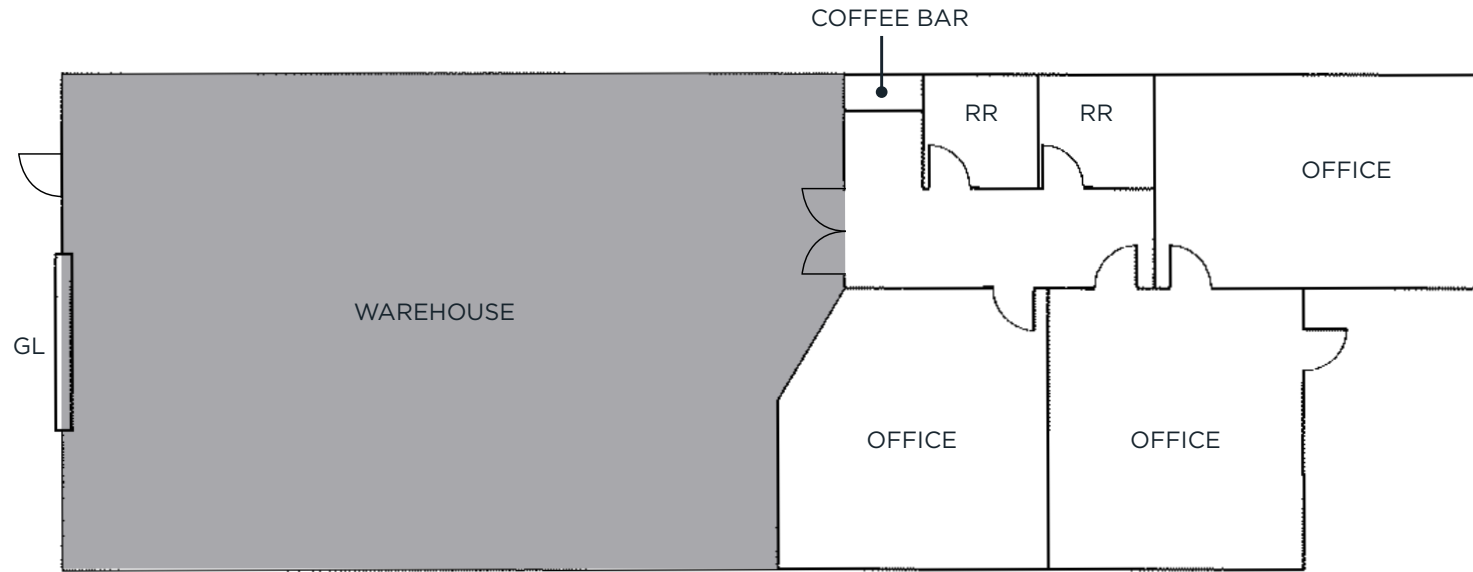

2958 SCOTT BOULEVARD | ±1,918 SF

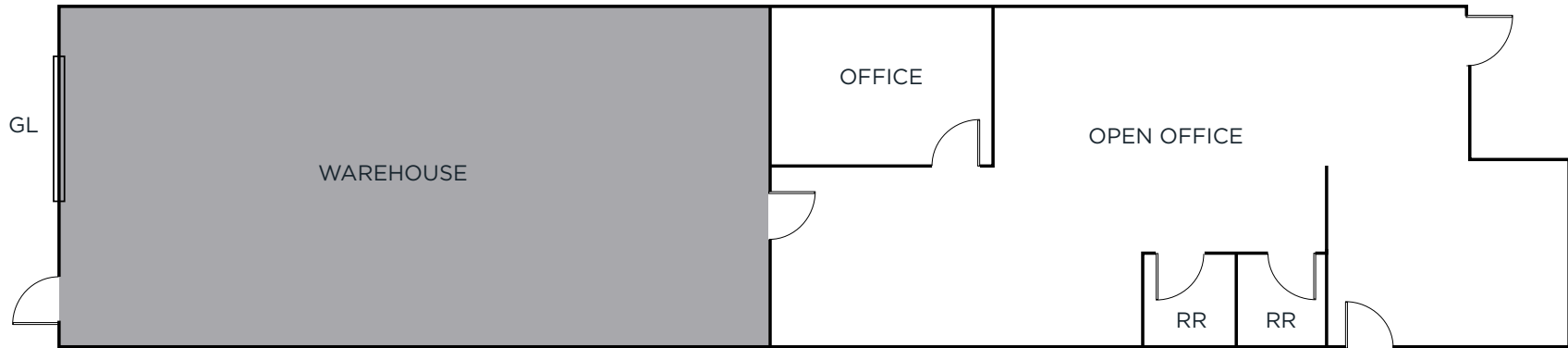

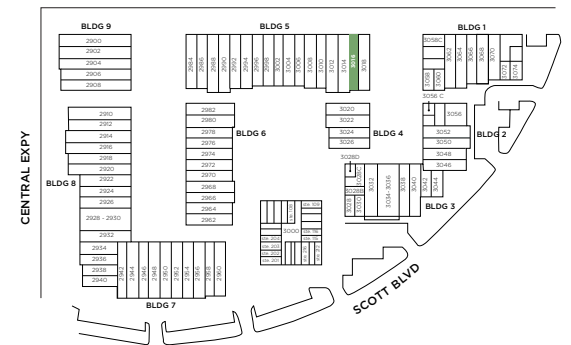
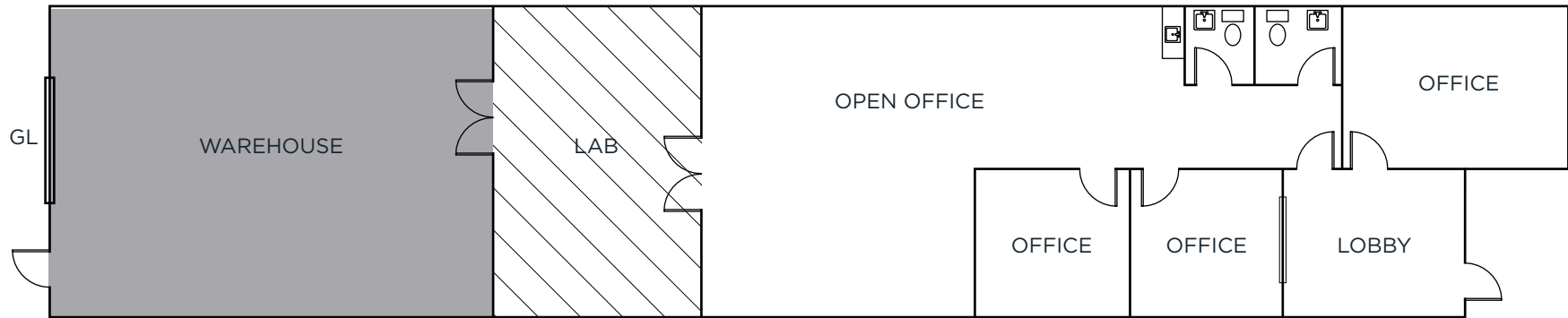

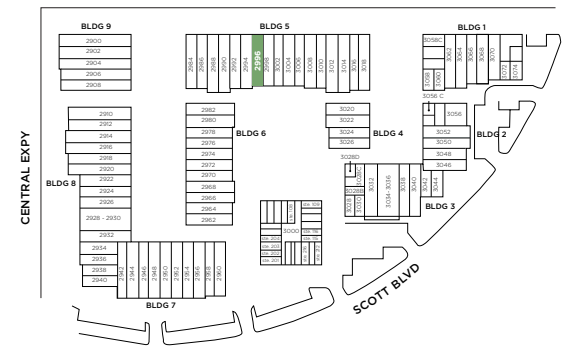
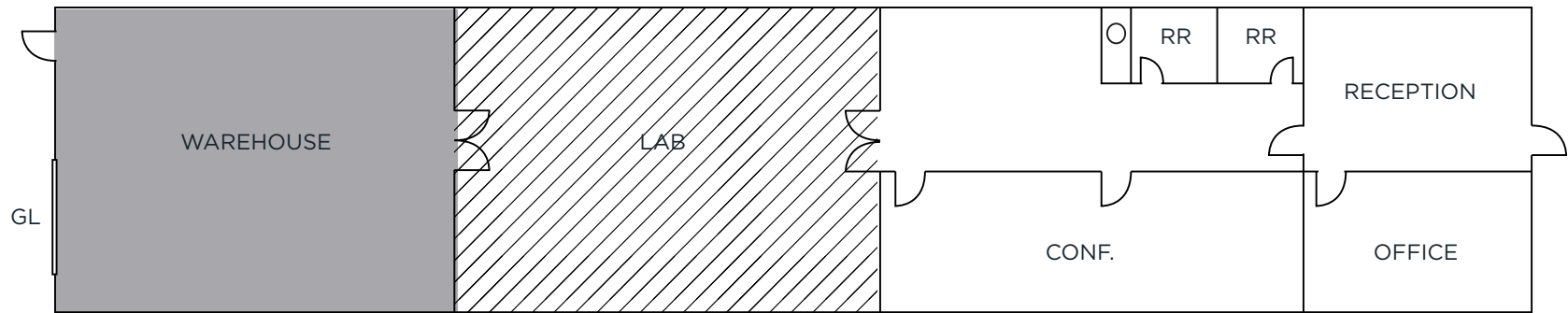

2996 SCOTT BOULEVARD | ±1,980 SF

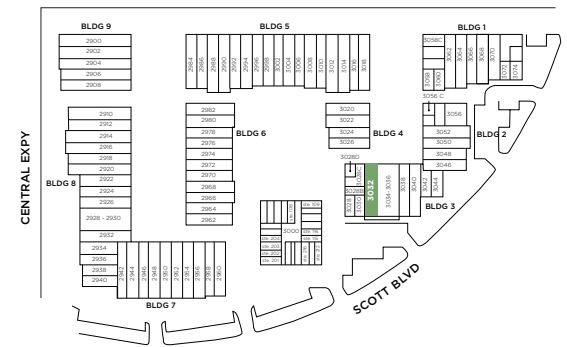
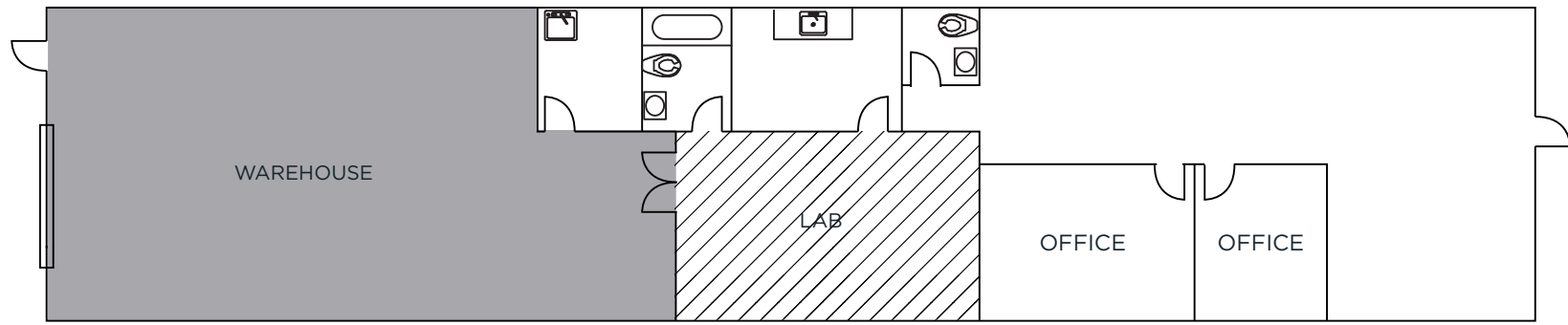

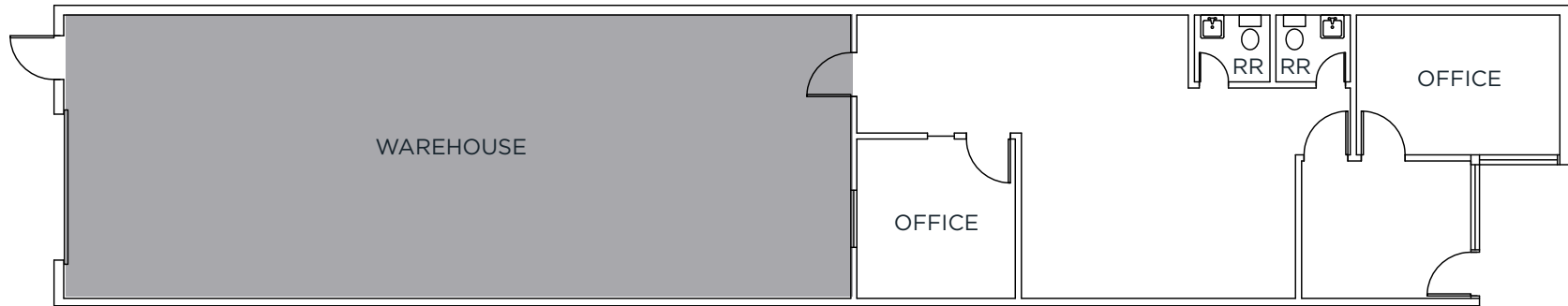

3012 SCOTT BOULEVARD | ±2,060 SF

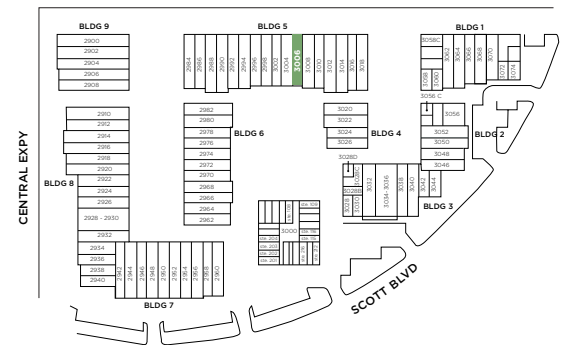

WAREHOUSE
 VCT / DROPPED CEILING

3006 SCOTT BOULEVARD | ±2,063 SF

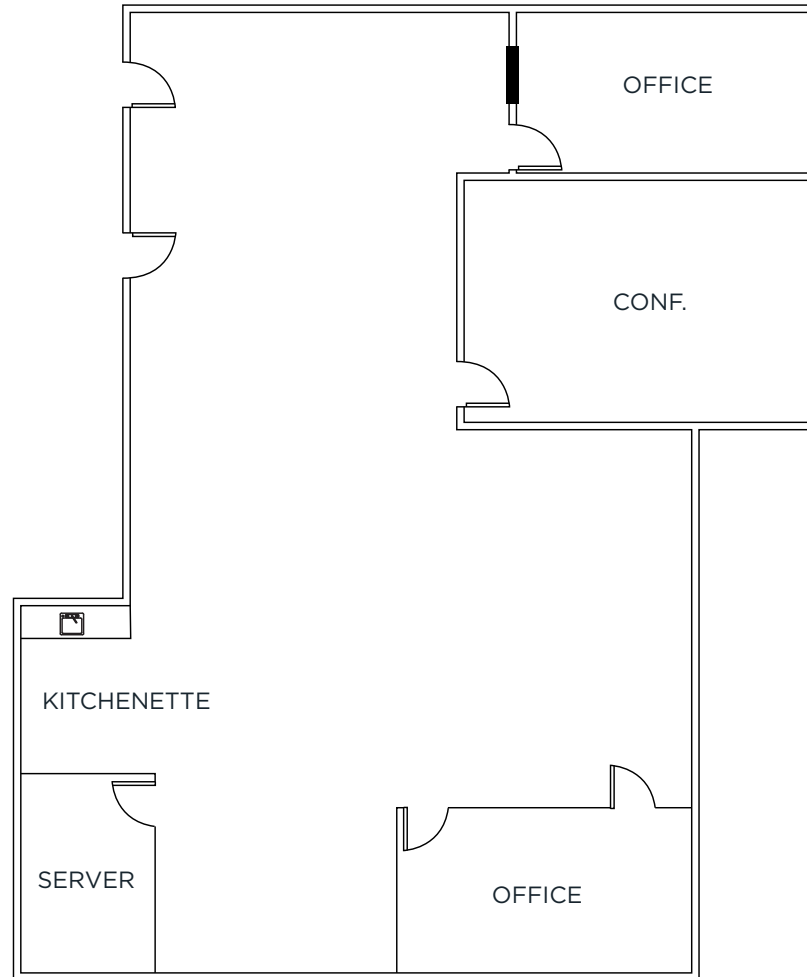

WAREHOUSE
 VCT / DROPPED CEILING

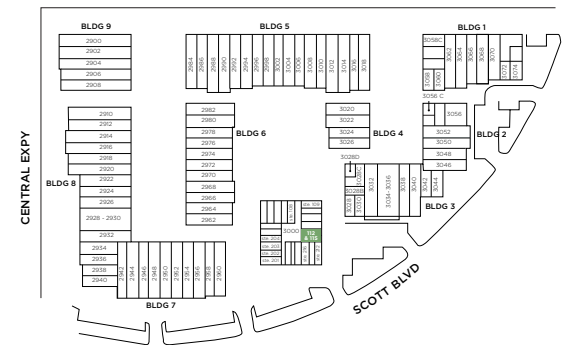

3000 SCOTT BOULEVARD, SUITES 112 & 115 | ±2,314 SF

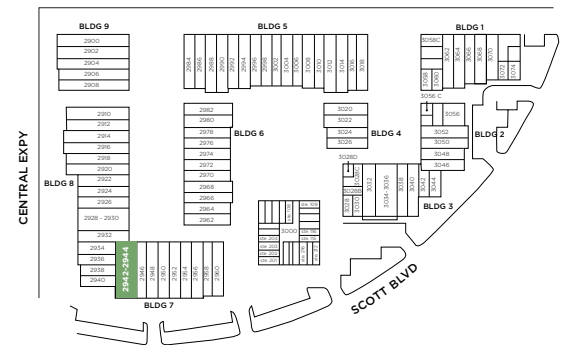
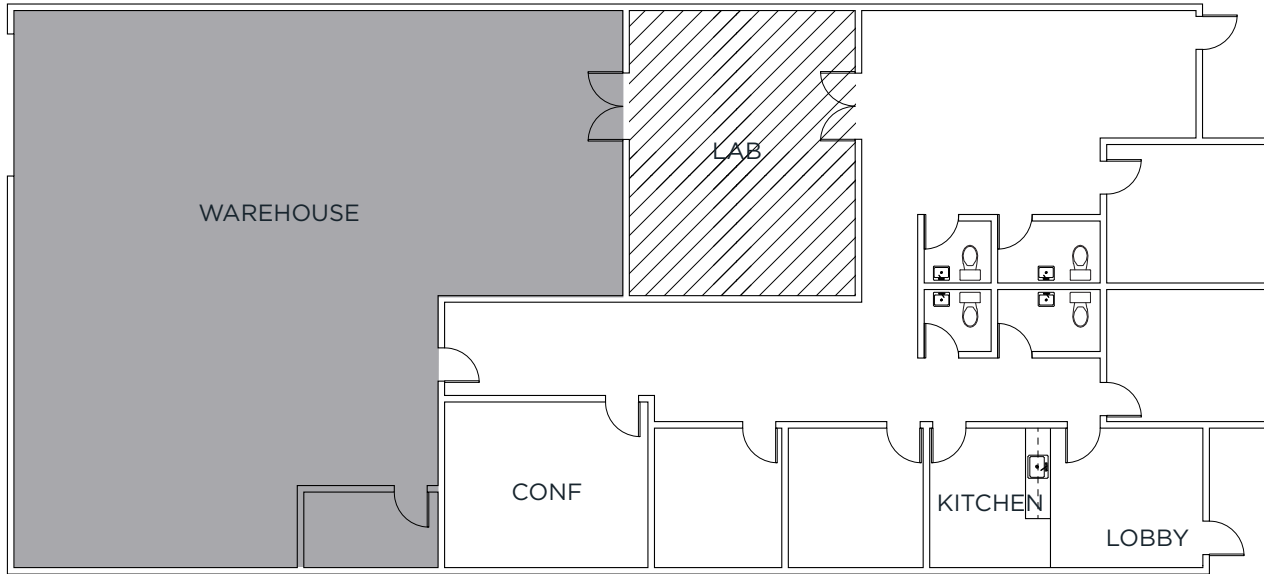

2942-2944 SCOTT BOULEVARD | ±4,040 SF

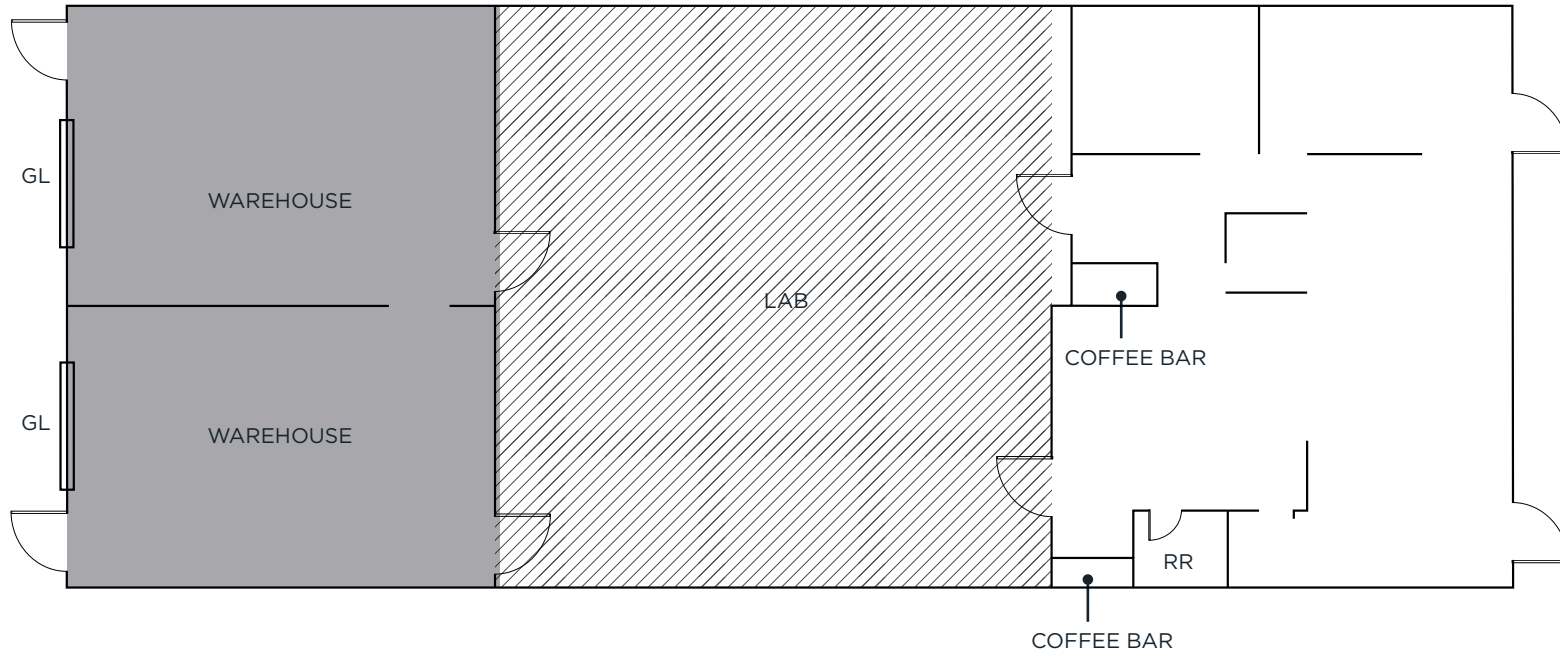

3034-3036 SCOTT BOULEVARD | ±4,110 SF

2928/2930: ±4,060 SF

2932: ±2,120 SF

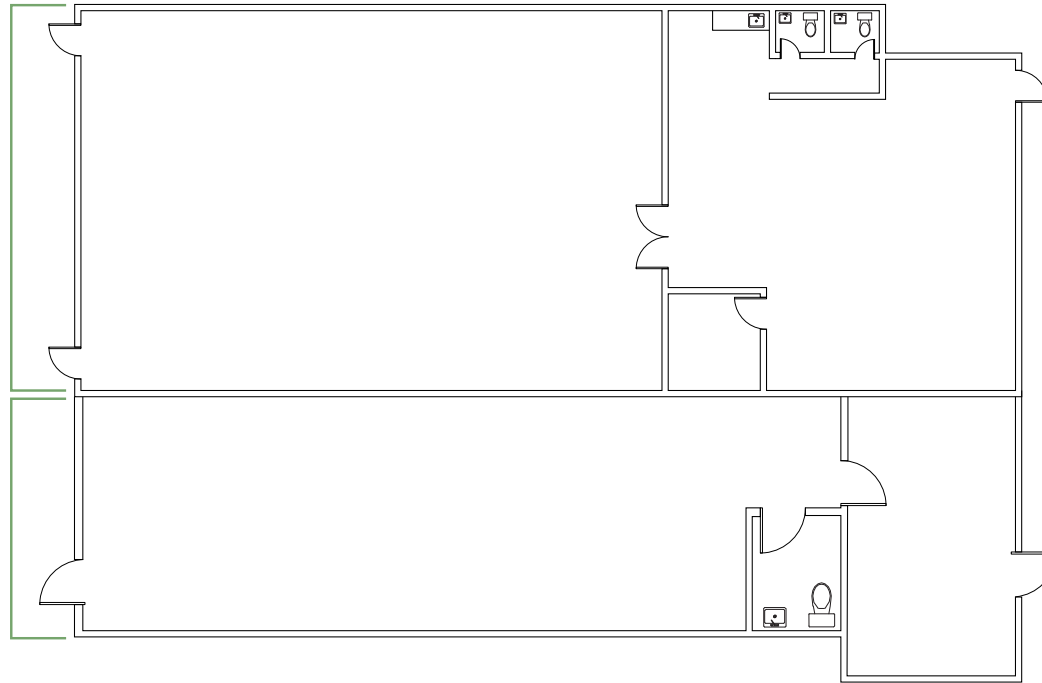

WAREHOUSE
 VCT / DROPPED CEILING

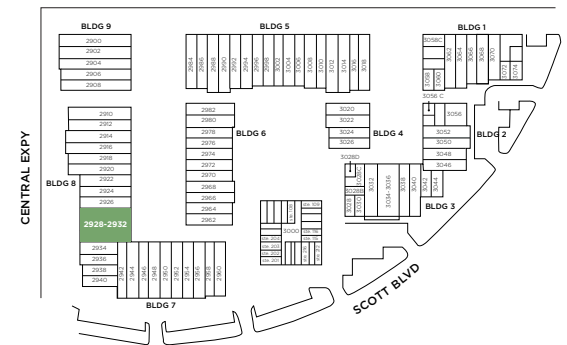

2928-2932 SCOTT BOULEVARD | ±6,180 SF

2914/2916: ±4,860 SF

2912: ±2,369 SF

2910: ±2,370 SF

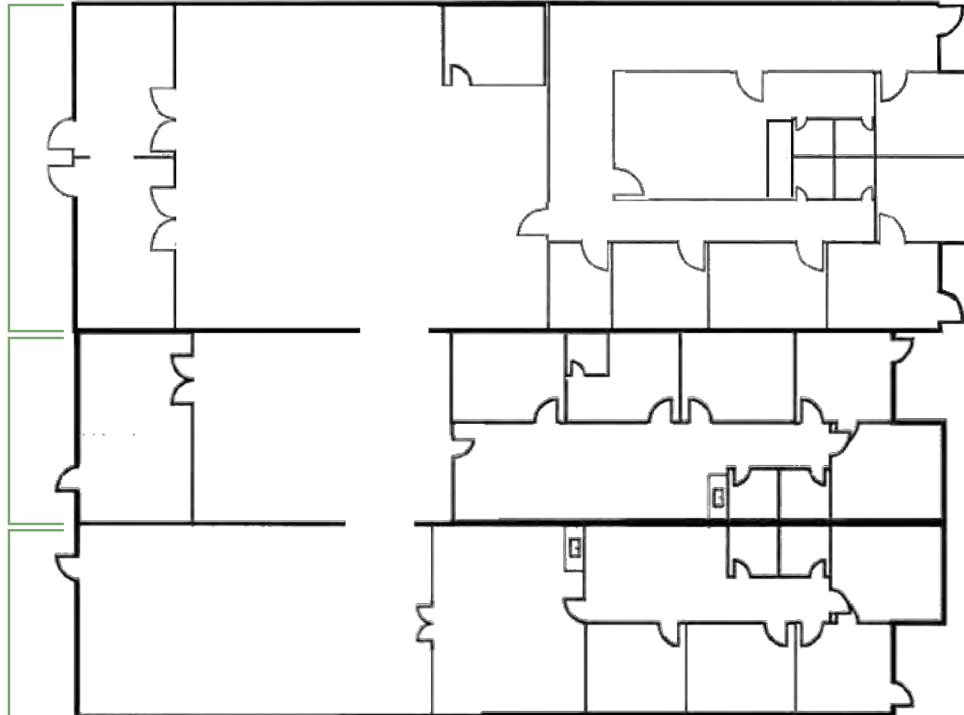

WAREHOUSE
 VCT / DROPPED CEILING

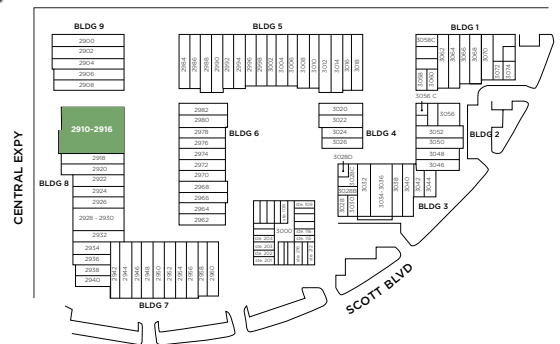

2910-2916 SCOTT BOULEVARD | ±9,599 SF

AMENITIES MAP



RESTAURANTS

- 1 BAMBOO LEAF
- 2 CRESCENT CUISINE
- 3 ATHENA GRILL
- 4 PHO VAN REST & DELI
- 5 MONTAGUE'S CAFE
- 6 SUBWAY
- 7 DELI PLACE 01
- 8 PEDRO'S
- 9 BIRK'S
- 10 SPECIALTY'S
- 11 WHOLE FOODS MARKET
- 12 IN-N-OUT BURGER

RETAIL

- 1 7-ELEVEN
- 2 VILLA MARKET
- 3 WALMART MARKET

BANKING

- 1 BANK OF AMERICA
- 2 US BANK
- 3 COMERICA BANK

GAS STATIONS

- 1 VALERO
- 2 SHELL
- 3 ROTTEN ROBBIE
- 4 SHELL



LOCATION MAP



SANTOMAS

COMMERCE PARK

Santa Clara, California

MIKE BAKER | +1 408 615 3406 | mike.baker@cushwake.com | LIC #01884037

WALT STEPHENSON | +1 408 615 3458 | walt.stephenson@cushwake.com | LIC #01793438



LINK
INDUSTRIAL



**CUSHMAN &
WAKEFIELD**

VIEW SITE SPECIFIC COVID-19 PREVENTION PLAN

Cushman & Wakefield Copyright 2020. No warranty or representation, express or implied, is made to the accuracy or completeness of the information contained herein, and same is submitted subject to errors, omissions, change of price, rental or other conditions, withdrawal without notice, and to any special listing conditions imposed by the property owner(s). As applicable, we make no representation as to the condition of the property (or properties) in question.