



3,290 SF First Floor Retail/Restaurant Space
Lease Rate: \$17.50 PSF NNN

Looking for restaurant/entertainment users who are looking to take advantage of this downtown Old Market location. Premises includes a small mezzanine and outdoor patio. Daytime population of approximately 40,000.

Kurt Weeder
Senior Associate
(402) 548 4001
kweeder@lundco.com

Martin J. Patzner, CMP, RPA
Vice President, Office Specialist
(402) 548 4033
mpatzner@lundco.com

450 Regency Parkway, Suite 200
Omaha, NE 68114
+1 402 393 8811
lundco.com

Independently Owned and Operated / A Member of the Cushman & Wakefield Alliance

Cushman & Wakefield Copyright 2018. No warranty or representation, express or implied, is made to the accuracy or completeness of the information contained herein, and same is submitted subject to errors, omissions, change of price, rental or other conditions, withdrawal without notice, and to any special listing conditions imposed by the property owner(s). As applicable, we make no representation as to the condition of the property (or properties) in question.



Property Highlights

Lease Rate	\$17.50 SF
Total Available	3,290 SF
Total Contiguous	3,290 SF
Building Size	273,400 SF
Year Built	1990
Total Site Area	67,591 AC
Parking	1.4/1,000 SFv
Parking Type	Street
On-Site Management	Yes
Traffic Counts	11,635 EADT
Operating Expenses	\$5.80



Independently Owned and Operated / A Member of the Cushman & Wakefield Alliance

Cushman & Wakefield Copyright 2018. No warranty or representation, express or implied, is made to the accuracy or completeness of the information contained herein, and same is submitted subject to errors, omissions, change of price, rental or other conditions, withdrawal without notice, and to any special listing conditions imposed by the property owner(s). As applicable, we make no representation as to the condition of the property (or properties) in question.

First Floor Plan

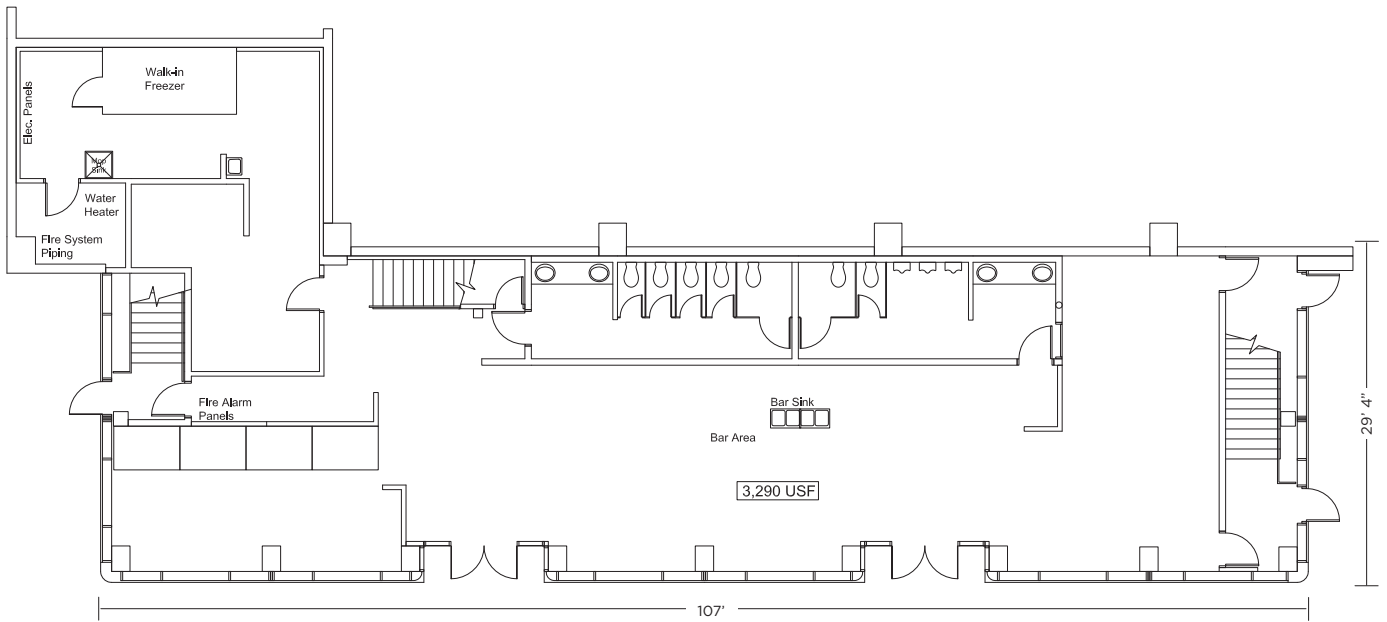

** Floor plan measurements are approximate and are for illustration purposes only.

Mezzanine Floor Plan

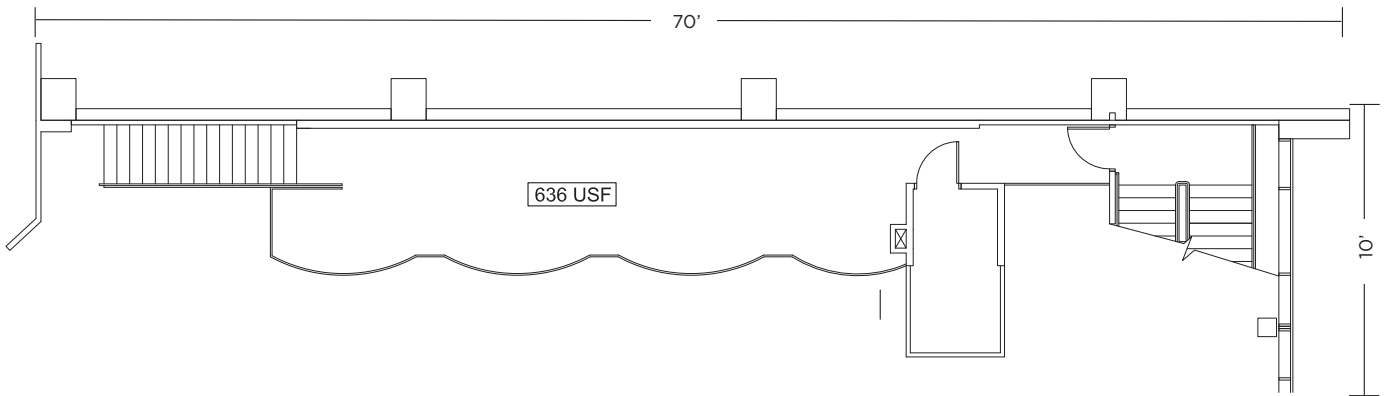

** Floor plan measurements are approximate and are for illustration purposes only.

FOR LEASE

1200 Landmark Center
302 S. 11th Street / Omaha, NE

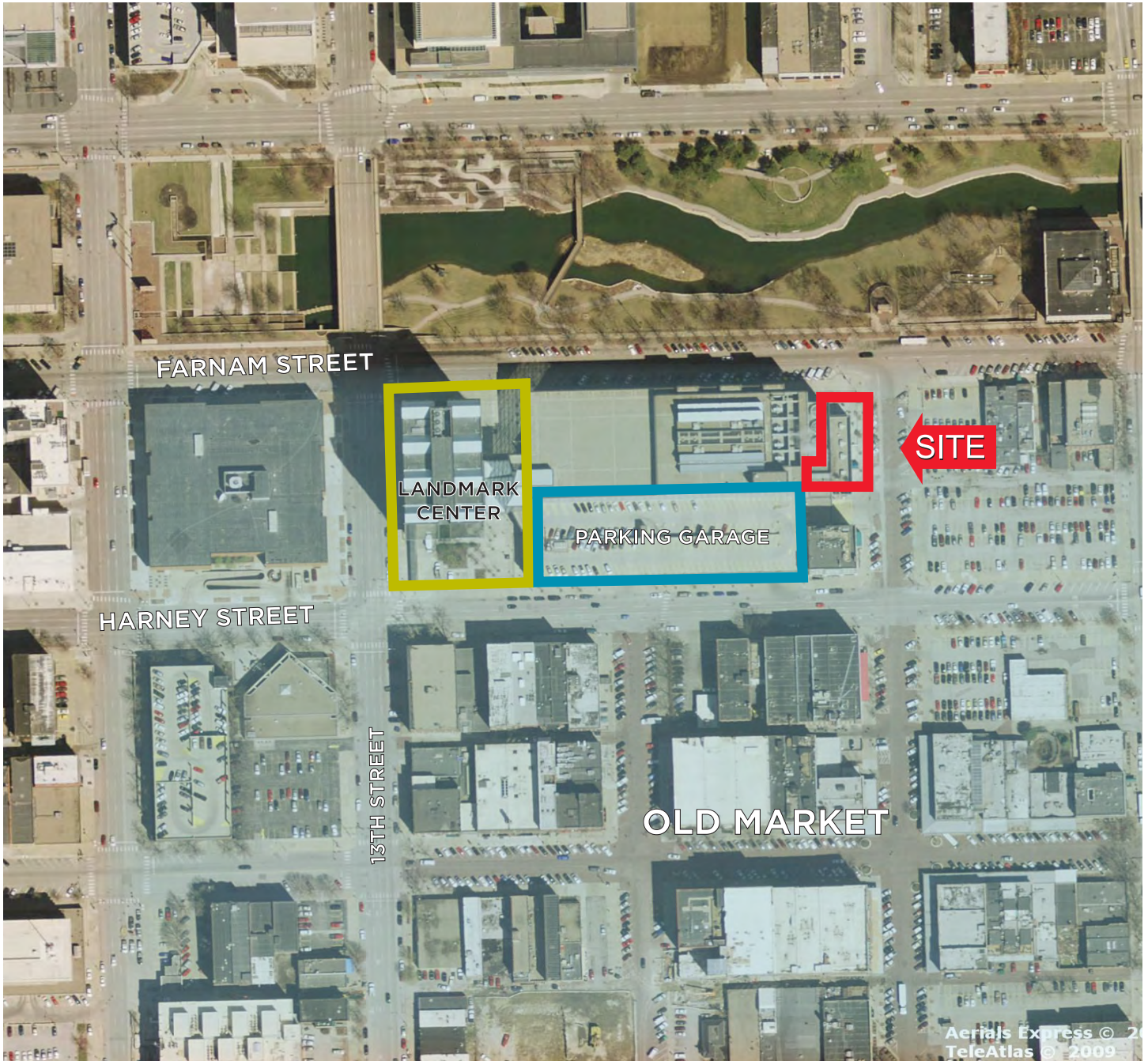

Independently Owned and Operated / A Member of the Cushman & Wakefield Alliance

Cushman & Wakefield Copyright 2018. No warranty or representation, express or implied, is made to the accuracy or completeness of the information contained herein, and same is submitted subject to errors, omissions, change of price, rental or other conditions, withdrawal without notice, and to any special listing conditions imposed by the property owner(s). As applicable, we make no representation as to the condition of the property (or properties) in question.