

40 WEST ACORN LANE

Lake In The Hills, IL 60156



NEWLY REMODELED TURN KEY DAYCARE

HIGHLIGHTS:

- **FOR LEASE:** 7,700 SF Available
- Originally Built in 1992 and Expanded in 2002
- Built on a 1.77 Acre Lot with 48 Surface Parking Spaces
- Building Zoned B-3 Business District

OPPORTUNITY IDENTIFICATION:

- Excellent Location for Medical, Services, or Office Users
- Prime Opportunity for Child-Related Retailers and Services to be Adjacent to a Little Minds Learning Center

TRAFFIC COUNTS:

- Randall Road: 37,600 VPD
- Algonquin Road: 35,200 VPD

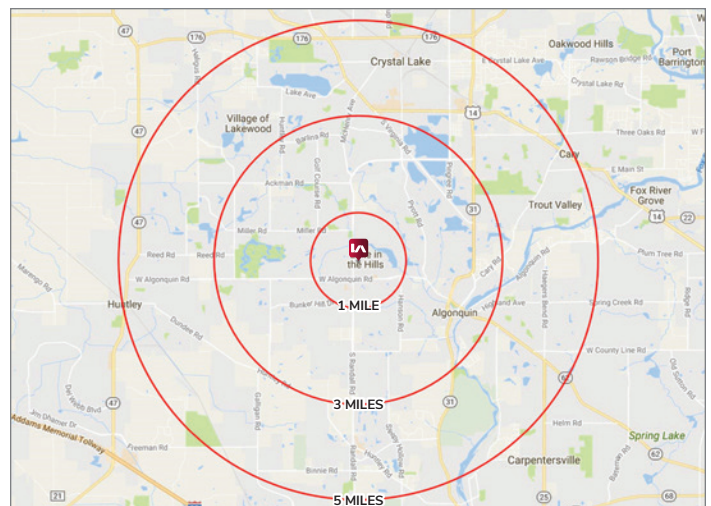

	1 MILE	3 MILES	5 MILES
Estimated Population	10,787	69,051	150,970
Number of Households	3,961	24,627	53,222
Household Income (AVG)	\$109,121	\$120,087	\$118,253
Daytime Population	8,586	35,541	91,272

A. RICK SCARDINO
Principal
rscardino@lee-associates.com
773.355.3040

40 WEST ACORN LANE

Lake In The Hills, IL 60156

RETAILER AERIAL



40 WEST ACORN LANE

Lake In The Hills, IL 60156

SITE PLAN

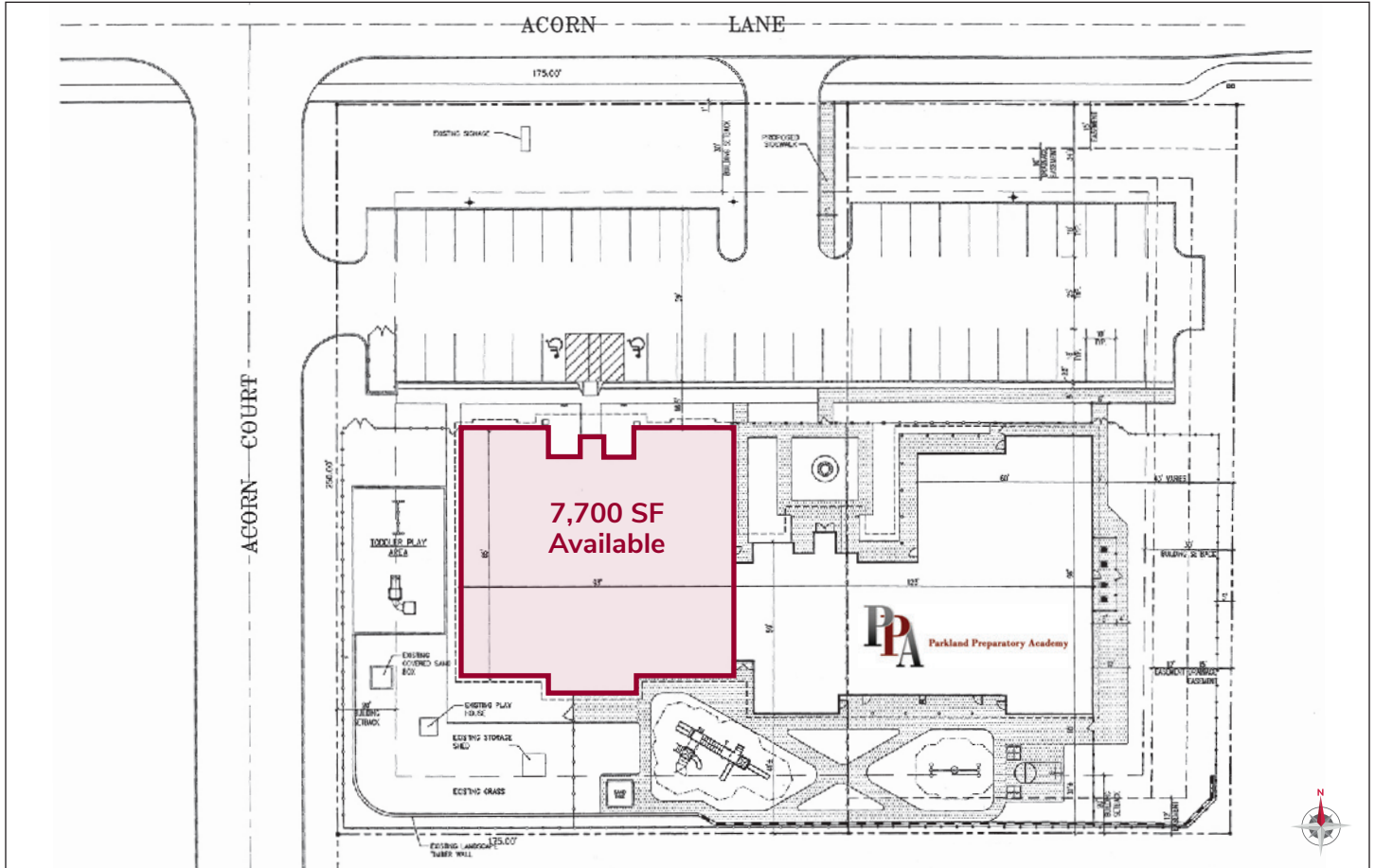

EXISTING FLOOR PLAN

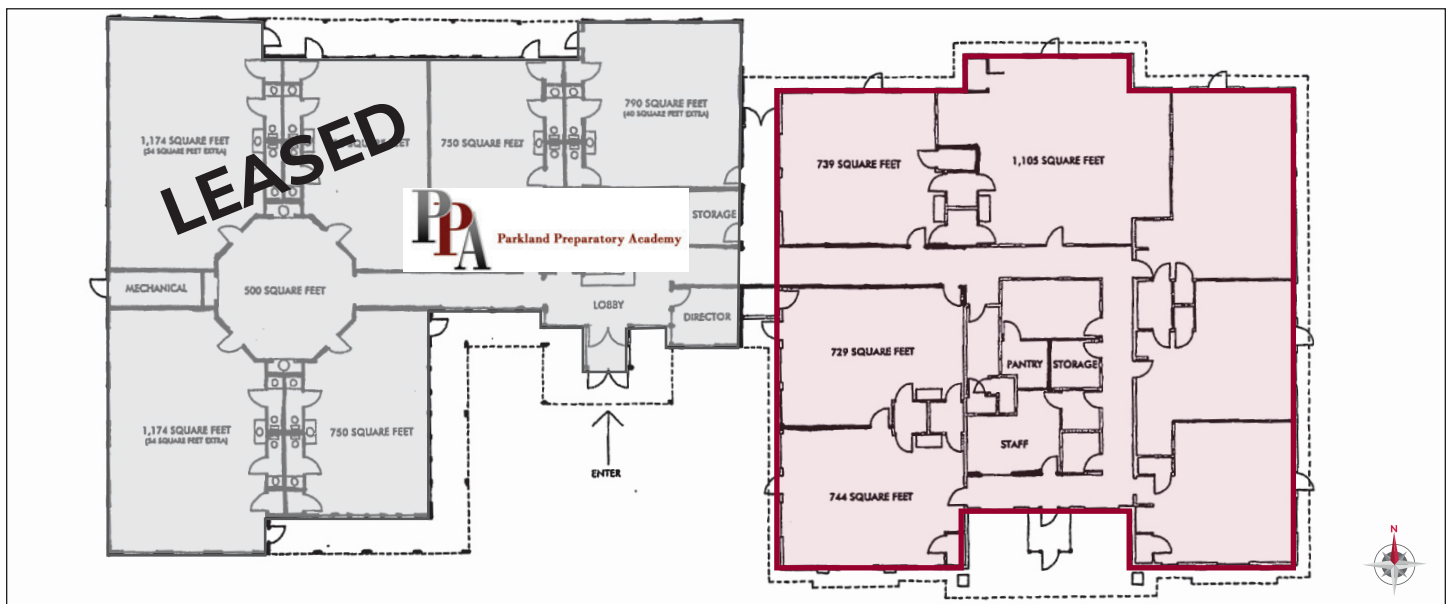

40 WEST ACORN LANE

Lake In The Hills, IL 60156

FLOOR PLAN

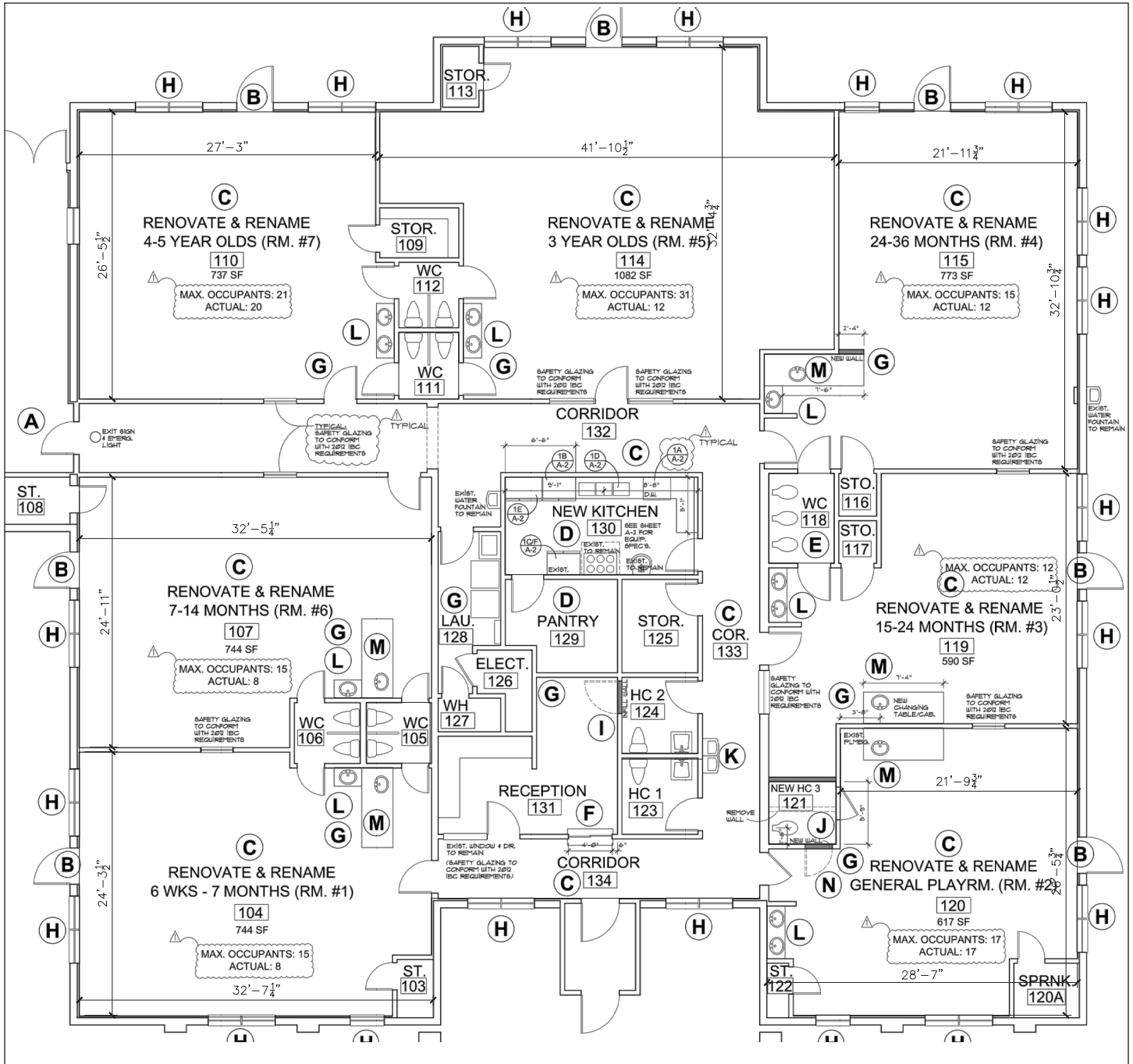

40 WEST ACORN LANE

Lake In The Hills, IL 60156



40 WEST ACORN LANE

Lake In The Hills, IL 60156

