

FOR LEASE- Industrial Office / Warehouse + Yard

5676 N Pecos Street, Denver, CO 80221 (Unincorporated Adams)



PROPERTY OVERVIEW:

City:	Denver
County:	Adams
Zoning:	I-3
Available SF:	12,745 SF
Total Bldg SF:	21,600 SF
Site SF:	1.73 Acres
YOC:	1972
Ceiling Height:	16' Clear
Power:	600A/115V-220V-240V/ 3P*
Construction:	Twin "T" Tilt up
Signage:	Facade
Parking:	Ample
HVAC:	GFA/Comp/ GFA Hanging
Drive-In Doors:	1 - 10' x 20', 1- 12' x 14'
Taxes:	\$28,318.92 (\$1.31/ SF) <small>*to be verified</small>

LEASE INFORMATION:

**\$5.50/SF/Year NNN (2011 NNN Est,
\$1.76/SF/Yr)**

PROPERTY FEATURES:

- **Heavy zoning allows multiple uses.**
- **Unincorporated Adams County.**
- **Enterprise Zone.**
- **Easy Access via Pecos and I-70.**
- **Fenced yard area available for outside storage.**
- **Excellent office finish, break room and conference room.**
- **Heavy power, large doors, bridge crane.**

EXCLUSIVELY LISTED BY:

Mark Goodman & Paul Schneider
1 Broadway, Suite 300A
Denver, CO 80203
Phone: (303) 962-9545
Fax: (303) 962-9984
mgoodman@pinnaclearea.com
pschneider@pinnaclearea.com

FOR LEASE - 5676 Pecos Street, Denver, CO 80221

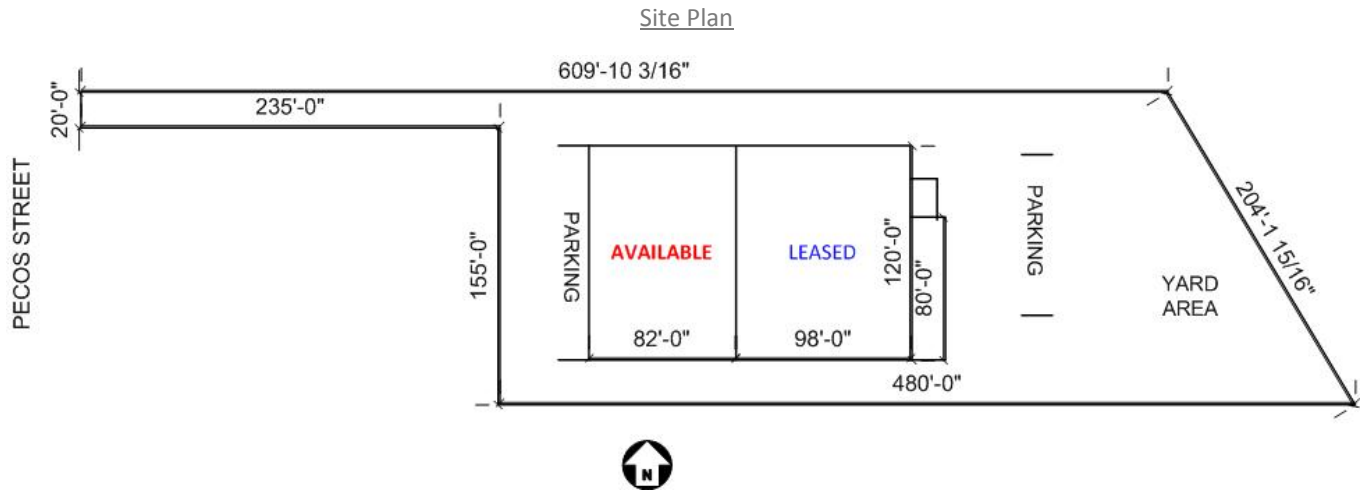

**All measurements are for visualization purposes and are approximate.*

Aerial View

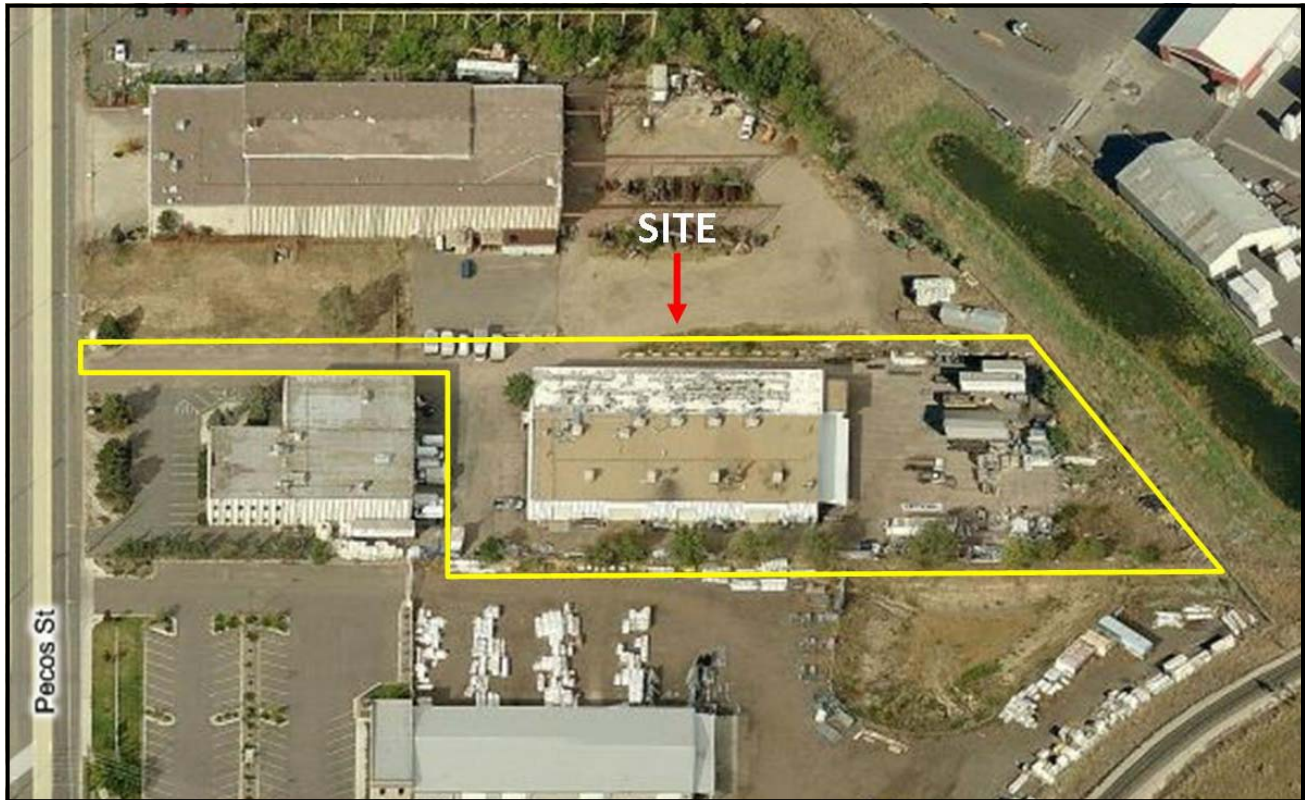

Please note, all information furnished in this presentation regarding this property for sale has been secured from sources we believe to be reliable. However, we accept no responsibility for its correctness and encourage the verification of all numbers prior to making any financial decisions. We owe duties to the seller, which include utmost good faith. We negotiate on behalf of and act as advocate for the seller. Please do not tell us any information that you do not want shared with the seller. You are not legally responsible for our actions. Although we do not represent you, we will disclose to you all adverse material facts about the property actually known to us. We will assist you without regard to race, creed, sex, religion, national origin, familial status or handicap.



FOR LEASE - 5676 Pecos Street, Denver, CO 80221

Floor Plan

Upstairs

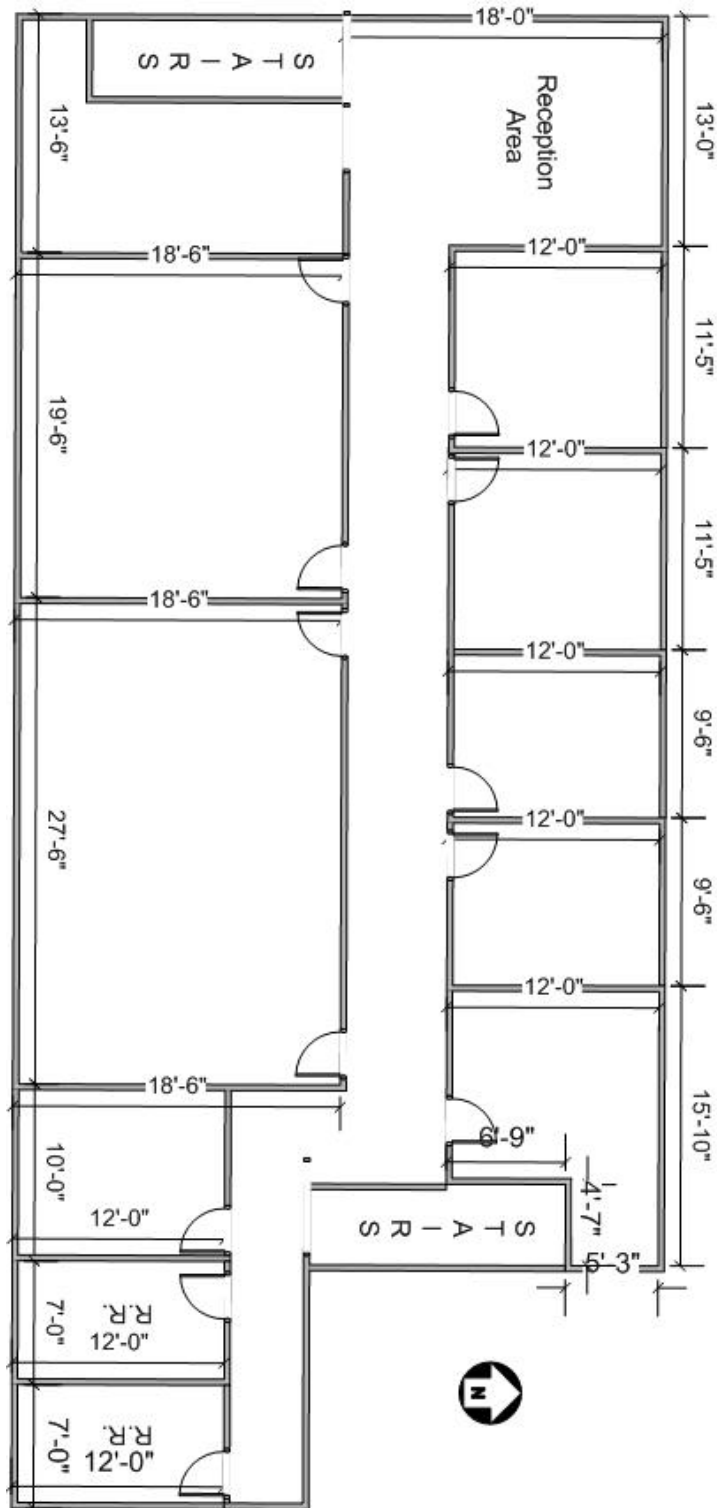

**All measurements are for visualization purposes and are approximate.*

Please note, all information furnished in this presentation regarding this property for sale has been secured from sources we believe to be reliable. However, we accept no responsibility for its correctness and encourage the verification of all numbers prior to making any financial decisions. We owe duties to the seller, which include utmost good faith. We negotiate on behalf of and act as advocate for the seller. Please do not tell us any information that you do not want shared with the seller. You are not legally responsible for our actions. Although we do not represent you, we will disclose to you all adverse material facts about the property actually known to us. We will assist you without regard to race, creed, sex, religion, national origin, familial status or handicap.

FOR LEASE - 5676 Pecos Street, Denver, CO 80221

Floor Plan

Downstairs

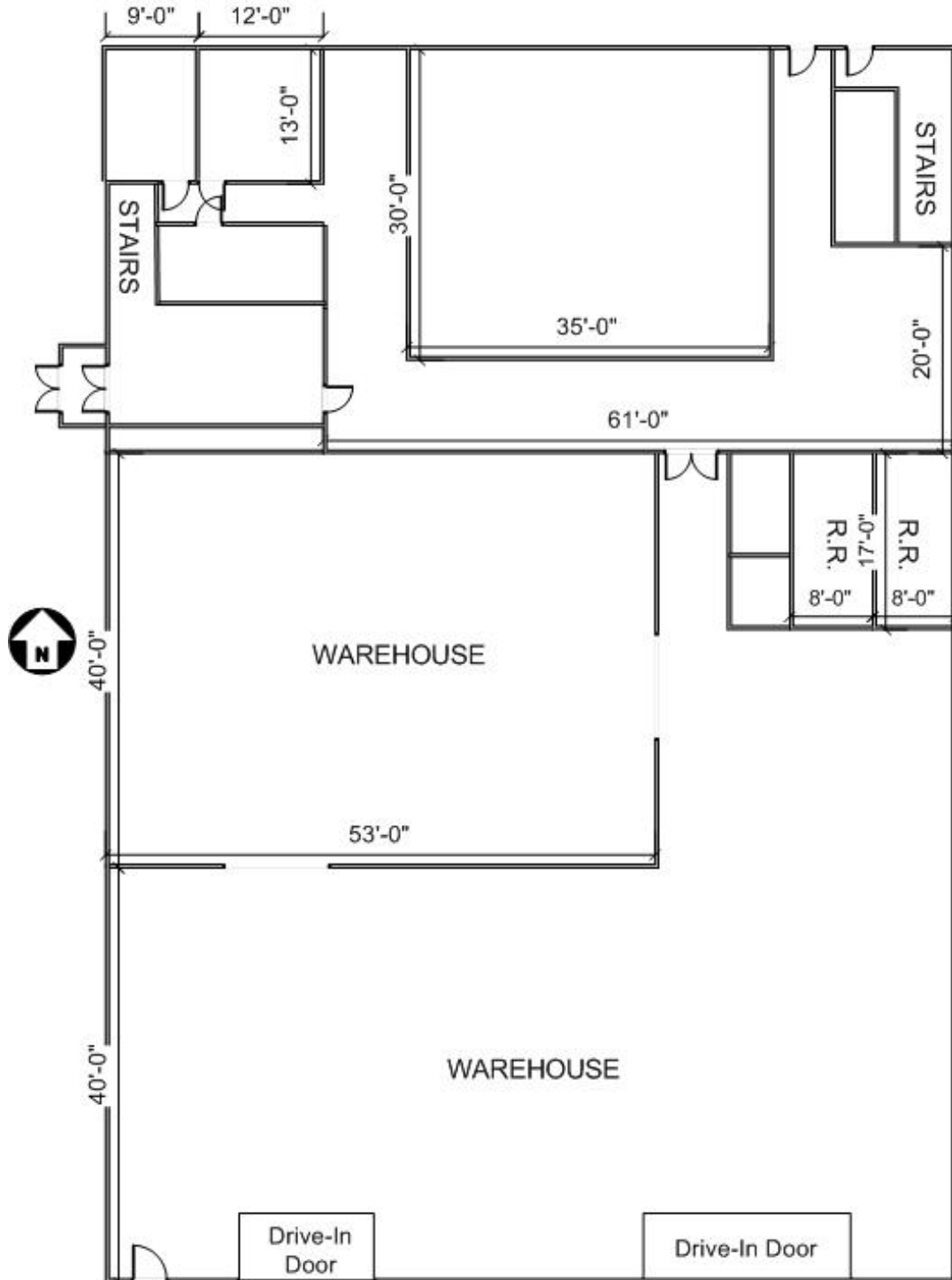

**All measurements are for visualization purposes and are approximate.*

Please note, all information furnished in this presentation regarding this property for sale has been secured from sources we believe to be reliable. However, we accept no responsibility for its correctness and encourage the verification of all numbers prior to making any financial decisions. We owe duties to the seller, which include utmost good faith. We negotiate on behalf of and act as advocate for the seller. Please do not tell us any information that you do not want shared with the seller. You are not legally responsible for our actions. Although we do not represent you, we will disclose to you all adverse material facts about the property actually known to us. We will assist you without regard to race, creed, sex, religion, national origin, familial status or handicap.