

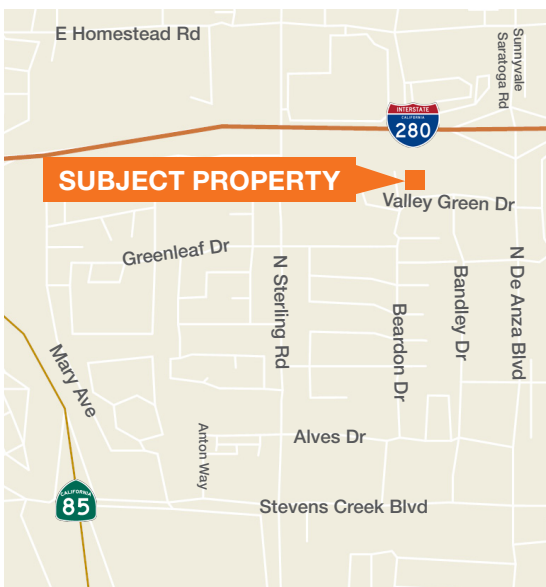

Available For Lease



Entire ground floor - ±2,050 SF

±3/1,000 parking with additional overflow and street parking

Glass interior finishes

Building upgrades in 2015

Potential future expansion in full building (±3,350 SF)

Monument signage

\$3.50 NNN

Call to tour

Contact

Derik Benson

408.588.2332

dbenson@kiddermathews.com

LIC #01182654

kiddermathews.com

Available For Lease

20725 Valley Green Drive, Cupertino, CA

First Floor - Available in 30 Days

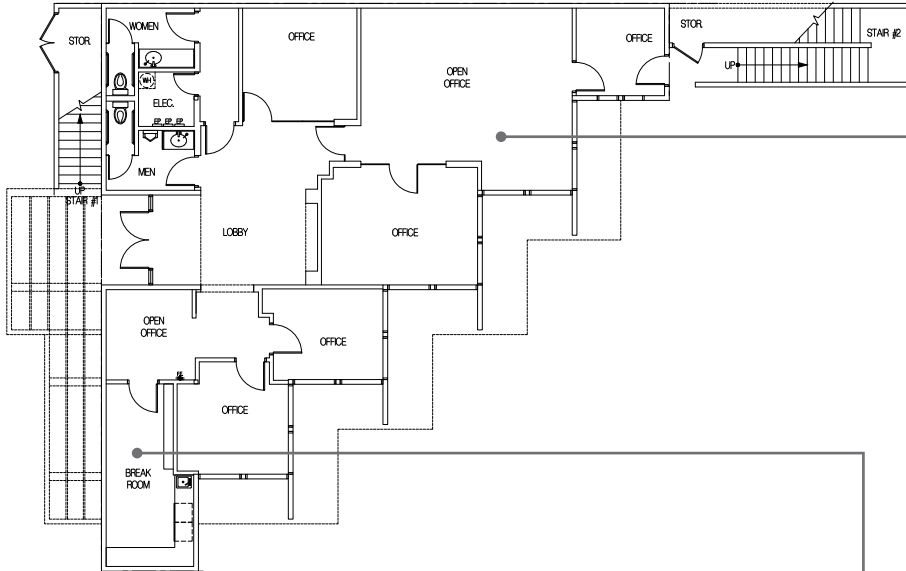

Second Floor - Potential Future Expansion Space

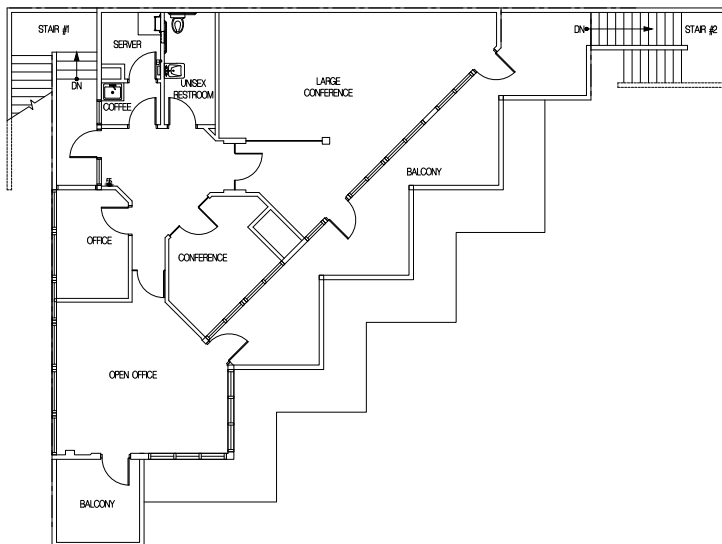

Contact

Derik Benson

408.588.2332

dbenson@kiddermathews.com

LIC #01182654

kiddermathews.com

This information supplied herein is from sources we deem reliable. It is provided without any representation, warranty or guarantee, expressed or implied as to its accuracy. Prospective Buyer or Tenant should conduct an independent investigation and verification of all matters deemed to be material, including, but not limited to, statements of income and expenses. Consult your attorney, accountant, or other professional advisor.

