

AustinOaks

a green office park

Leasing Availabilities



Matt Frizzell

E matt.frizzell@cushwake.com
T +1 512 814 3404

Tom Rhea

E tom.rhea@cushwake.com
T +1 512 814 3416

Austin Oaks is Austin's largest infill office park consisting of 12 buildings totaling 445,332 square feet. Nestled amongst 38 acres along MoPac Expressway (Loop 1) in Northwest Austin, the campus was acquired by The Luzzatto Company in August of 2018. The low profile design of the buildings are scaled to integrate seamlessly into the surrounding ecology. Plans are currently in progress to bring an enhanced creative perspective to Austin Oaks and emphasize the site's unique green spaces through incorporation of artwork, health and wellness amenities, increased connectivity and preservation of the natural serenity.

Matt Frizzell

E matt.frizzell@cushwake.com
T +1 512 814 3404

Tom Rhea

E tom.rhea@cushwake.com
T +1 512 814 3416

AustinOaks



Matt Frizzell
E matt.frizzell@cushwake.com
T +1 512 814 3404

Tom Rhea
E tom.rhea@cushwake.com
T +1 512 814 3416

AustinOaks

Conceptual Renderings



Matt Frizzell
E matt.frizzell@cushwake.com
T +1 512 814 3404

Tom Rhea
E tom.rhea@cushwake.com
T +1 512 814 3416

AVAILABILITY BY SIZE

Buchanan, Suite 203	429 SF	Bridgeport, Suite 209	1,063 SF
Buchanan, Suite 209	461 SF (Avail. 1.1.20)	Proctor, Suite 200	1,077 SF
Buchanan, Suite 210	463 SF	Meredith, Suite 108	1,099 SF
Whitney, Suite 105	485 SF	Medina, Suite 120	1,127 SF
Proctor, Suite 159	496 SF	Buchanan, Suite 215	1,251 SF
Bridgeport, Suite 150	500 SF	Colorado, Suite G22	1,277 SF
Bridgeport, Suite 152	504 SF	Bridgeport, Suite 100	1,390 SF
Benbrook, Suite 120	513 SF	Medina, Suite 100	1,423 SF
Bridgeport, Suite 158	624 SF	Benbrook, Suite 260	1,446 SF
Benbrook, Suite 108	740 SF	Proctor, Suite 215	1,527 SF
Colorado, Suite 207	761 SF	Meredith, Suite 201B	1,600 SF
Colorado, Suite G50	799 SF	Buchanan, Suite 202	1,688 SF
Whitney, Suite 225	865 SF	Cross, Suite 205	1,717 SF (Avail. 2.1.20)
Buchanan, Suite 216	883 SF	Buchanan, Suite 110	1,725 SF
Buchanan, Suite 104	949 SF	Benbrook, Suite 150	1,812 SF
Colorado, Suite 201	1,033 SF	Colorado, Suite 158	1,816 SF

Matt Frizzell

E matt.frizzell@cushwake.com
T +1 512 814 3404

Tom Rhea

E tom.rhea@cushwake.com
T +1 512 814 3416

AVAILABILITY BY SIZE

Whitney, Suite 211	1,841 SF	Livingston, Suite 160	3,216 SF
Proctor, Suite 152	2,008 SF	Colorado, Suite 165	3,325 SF
Proctor, Suite 150	2,064 SF	Travis, Suite 300	3,891 SF
Livingston, Suite 205	2,078 SF	Hubbard, Suite 200	9,254 SF (Avail. in 90 days)
Travis, Suite 159	2,117 SF		
Livingston, Suite 114	2,128 SF		
Proctor, Suite 250	2,135 SF		
Benbrook, Suite 151	2,215 SF		
Meredith, Suite 205	2,223 SF		
Colorado, Suite G10	2,375 SF		
Meredith, Suite 215	2,449 SF		
Bridgeport, Suite 201	2,496 SF		
Proctor, Suite 210	2,546 SF		
Bridgeport, Suite 110	2,634 SF		
Travis, Suite 150	2,669 SF		
Medina, Suite 151	3,018 SF		

Matt Frizzell

E matt.frizzell@cushwake.com
 T +1 512 814 3404

Tom Rhea

E tom.rhea@cushwake.com
 T +1 512 814 3416

AustinOaks

Features & Availabilities



FEATURES

Recent common area renovations

New landscaping and paint in all buildings

Minutes from Anderson Lane Retail, The Domain, Arboretum, Downtown Austin and neighboring shopping centers

Austin Oaks consists of 12 buildings on 38 beautiful acres

Less than a mile from 50 locally owned retail shops and restaurants

TOTAL SF

445,322

PARKING

4.08 : 1,000

OWNED BY

The Luzzatto Company

MANAGEMENT & LEASING CENTER

Cross Building
7718 Wood Hollow Dr, G10
Austin, TX 78731

Matt Frizzell

E matt.frizzell@cushwake.com
T +1 512 814 3404

Tom Rhea

E tom.rhea@cushwake.com
T +1 512 814 3416

AustinOaks

Location Map

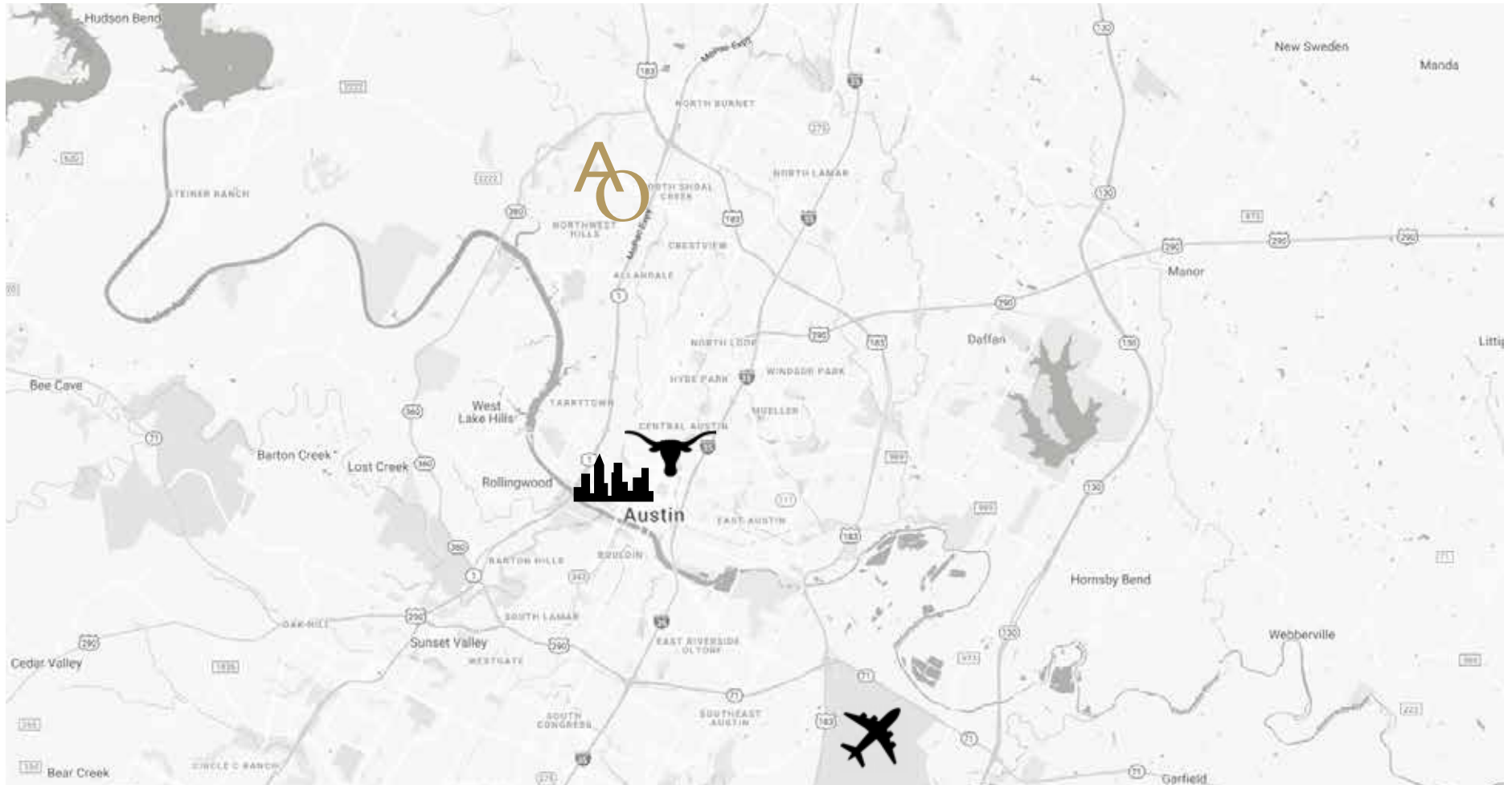

AUSTIN BERGSTROM INTERNATIONAL AIRPORT

20 miles, 23 minutes driving

DOWNTOWN AUSTIN

7 miles, 12 minutes driving

UNIVERSITY OF TEXAS

6 miles, 10 minutes

Matt Frizzell

E matt.frizzell@cushwake.com
T +1 512 814 3404

Tom Rhea

E tom.rhea@cushwake.com
T +1 512 814 3416

AustinOaks

Nearby Amenities & Destinations



ANDERSON LANE

1 mile, 4 minutes driving, 6 minutes cycling

SHOPS AT ARBOR WALK

2 miles, 6 minutes driving

GATEWAY SHOPPING CENTER

2 miles, 6 minutes driving

ARBORETUM AT GREAT HILLS

2 miles, 4 minutes driving

THE DOMAIN

3 miles, 5 minutes driving

HEALTH & WELLNESS

Within 2.5 miles of Austin Oaks are more than 8 yoga and pilates studios, 5 gym and training facilities, 5 fresh food and produce providers as well as multiple options for physical, dental, optical and mental health treatments and therapy.

Matt Frizzell

E matt.frizzell@cushwake.com

T +1 512 814 3404

Tom Rhea

E tom.rhea@cushwake.com

T +1 512 814 3416



1 BUCHANAN
3409 Executive Center Dr
28,011 sf

4 LIVINGSTON
3420 Executive Center Dr
51,216 sf

7 CROSS
7718 Wood Hollow Dr
43,719 sf

10 BRIDGEPORT
3701 Executive Center Dr
31,855 sft

2 HUBBARD
3429 Executive Center Dr
30,672 sf

5 TRAVIS
3520 Executive Center Dr
50,509 sf

8 COLORADO
3636 Executive Center Dr
38,030 sf

11 MEREDITH
3721 Executive Center Dr
42,728 sf

3 MEDINA
3445 Executive Center Dr
29,154 sf

6 WHITNEY
7719 Wood Hollow Dr
28,587 sf

9 PROCTOR
3724 Executive Center Dr
39,486 sf

12 BENBROOK
3737 Executive Center Dr
31,310 sf

Matt Frizzell
E matt.frizzell@cushwake.com
T +1 512 814 3404

Tom Rhea
E tom.rhea@cushwake.com
T +1 512 814 3416

AustinOaks

Project Amenity & Art Installation Map



1 BUCHANAN
3409 Executive Center Dr
28,011 sf

4 LIVINGSTON
3420 Executive Center Dr
51,216 sf

7 CROSS
7718 Wood Hollow Dr
43,719 sf

10 BRIDGEPORT
3701 Executive Center Dr
31,855 sft

2 HUBBARD
3429 Executive Center Dr
30,672 sf

5 TRAVIS
3520 Executive Center Dr
50,509 sf

8 COLORADO
3636 Executive Center Dr
38,030 sf

11 MEREDITH
3721 Executive Center Dr
42,728 sf

3 MEDINA
3445 Executive Center Dr
29,154 sf

6 WHITNEY
7719 Wood Hollow Dr
28,587 sf

9 PROCTOR
3724 Executive Center Dr
39,486 sf

12 BENBROOK
3737 Executive Center Dr
31,310 sf

Matt Frizzell
E matt.frizzell@cushwake.com
T +1 512 814 3404

Tom Rhea
E tom.rhea@cushwake.com
T +1 512 814 3416

AustinOaks

Suite 203
Second floor
429 sf

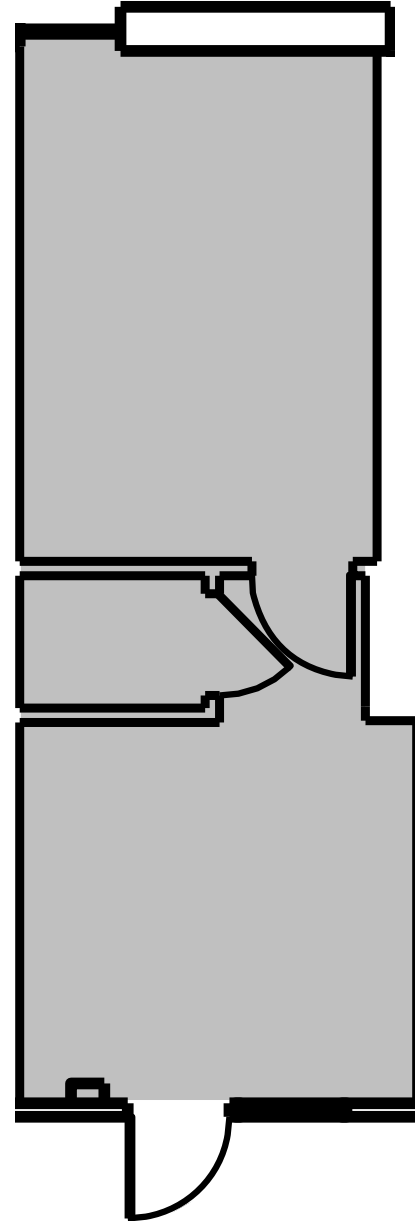
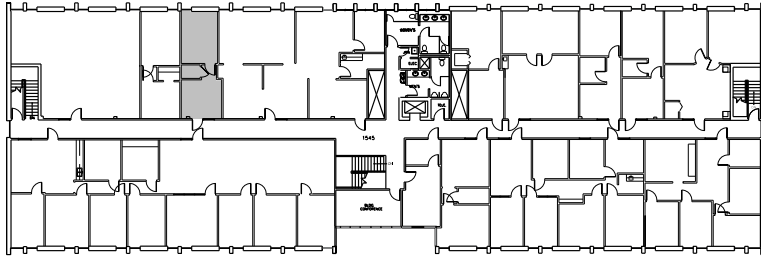

Building

1

Matt Frizzell

E matt.frizzell@cushwake.com

T +1 512 814 3404

Tom Rhea

E tom.rhea@cushwake.com

T +1 512 814 3416

AustinOaks

Suite 209
Second floor
461 sf

Available 1.1.20

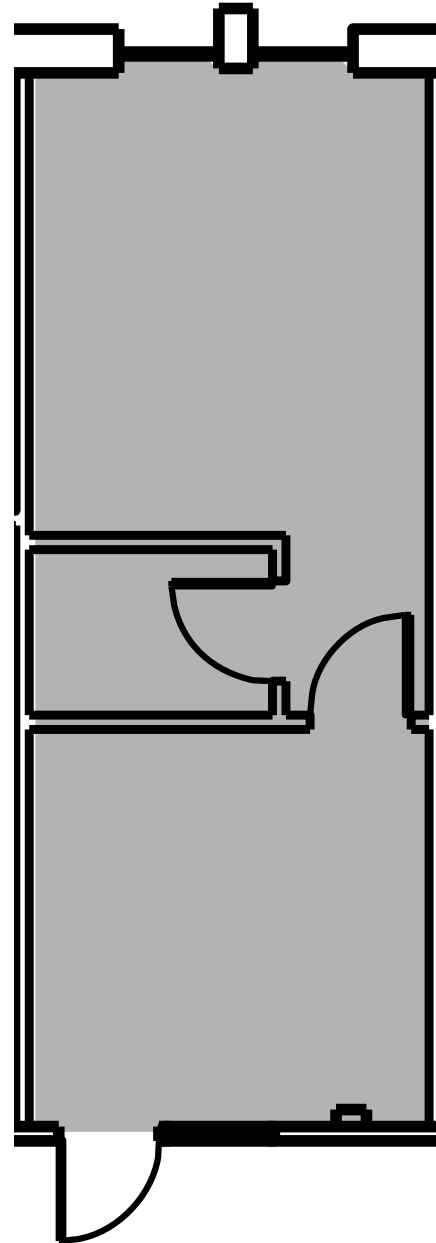
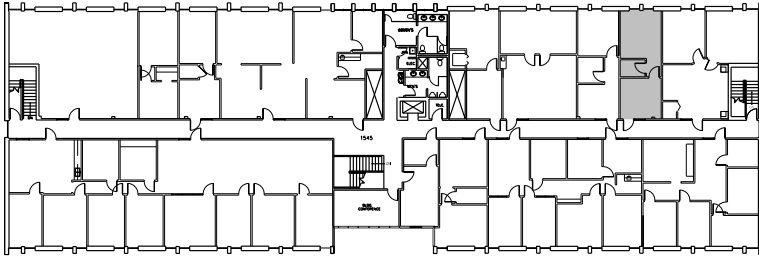

Building

1

Matt Frizzell

E matt.frizzell@cushwake.com

T +1 512 814 3404

Tom Rhea

E tom.rhea@cushwake.com

T +1 512 814 3416

AustinOaks

Suite 210
Second floor
463 sf

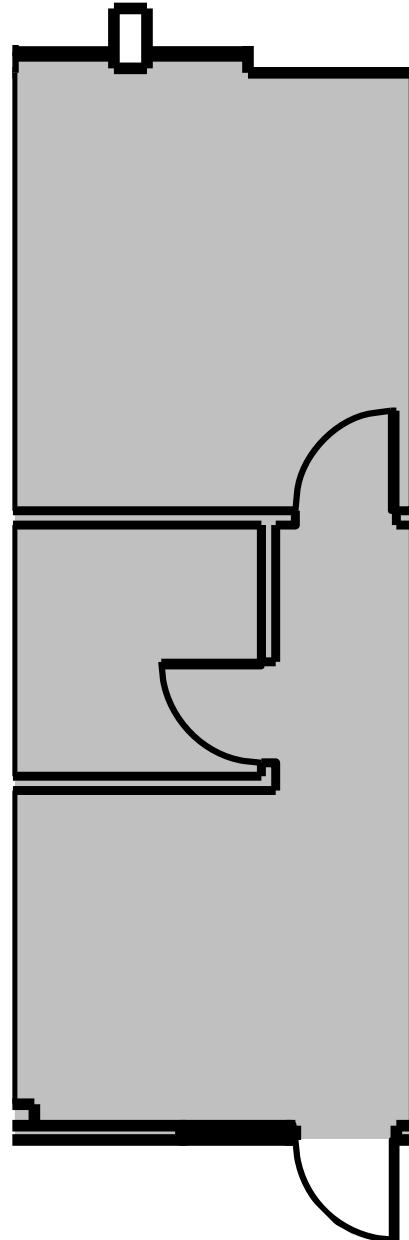
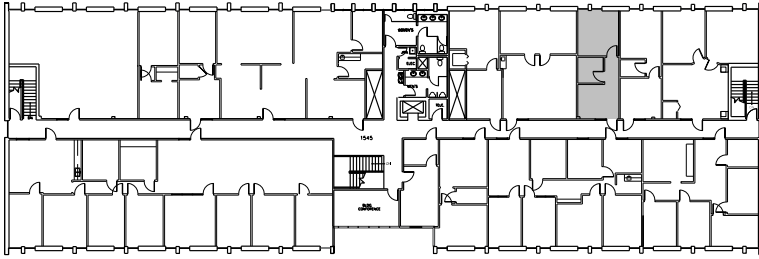

Building

1

Matt Frizzell
E matt.frizzell@cushwake.com
T +1 512 814 3404

Tom Rhea
E tom.rhea@cushwake.com
T +1 512 814 3416

AustinOaks

Suite 105
First floor
485 sf

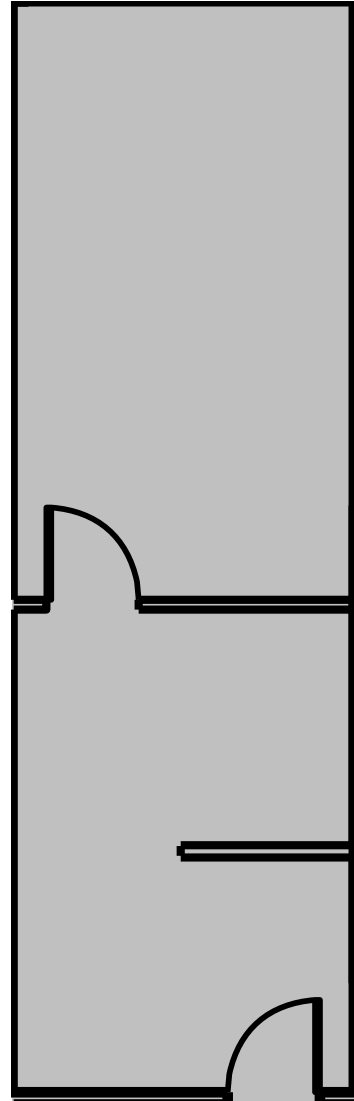
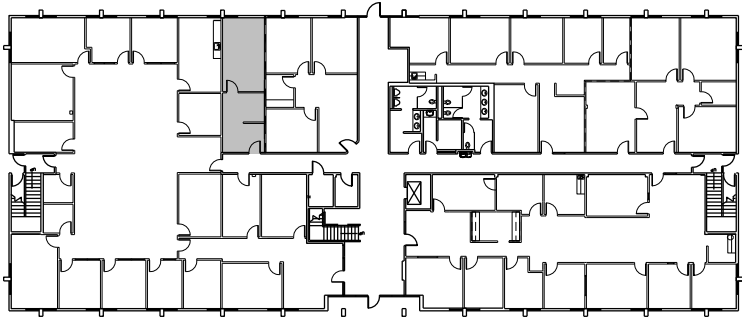

Building

6

Matt Frizzell

E matt.frizzell@cushwake.com

T +1 512 814 3404

Tom Rhea

E tom.rhea@cushwake.com

T +1 512 814 3416

AustinOaks

Suite 159
First floor
496 sf

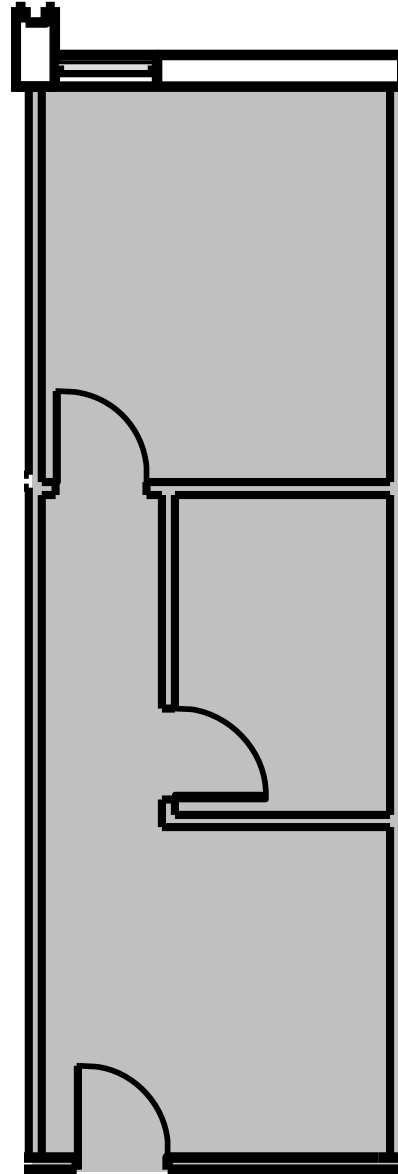
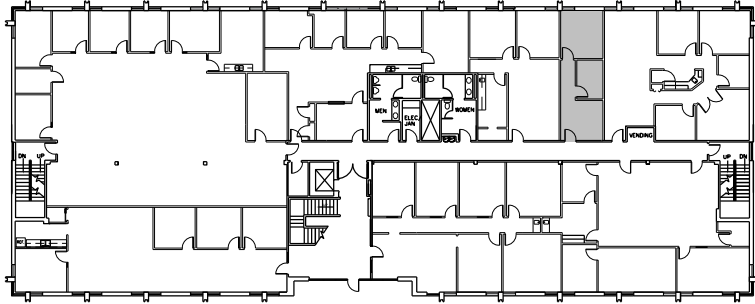

Matt Frizzell

E matt.frizzell@cushwake.com

T +1 512 814 3404

Tom Rhea

E tom.rhea@cushwake.com

T +1 512 814 3416

AustinOaks

Suite 150
First floor
500 sf

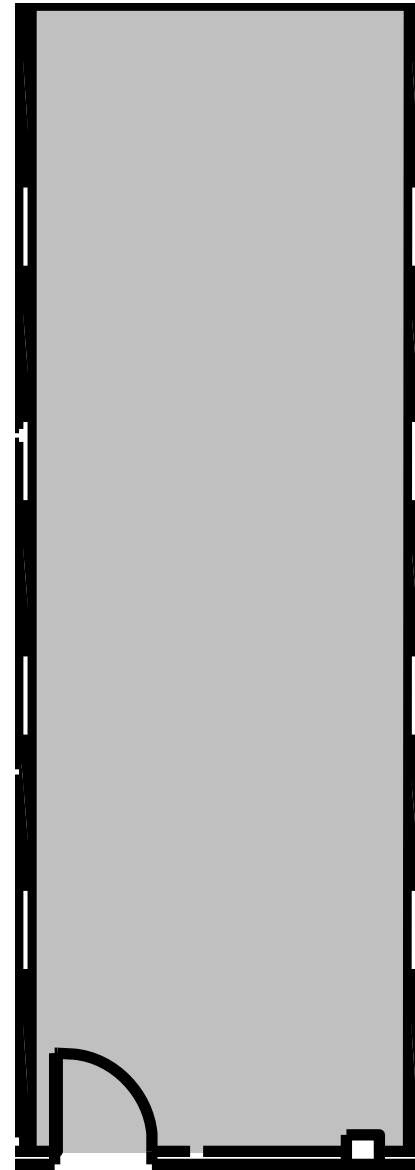
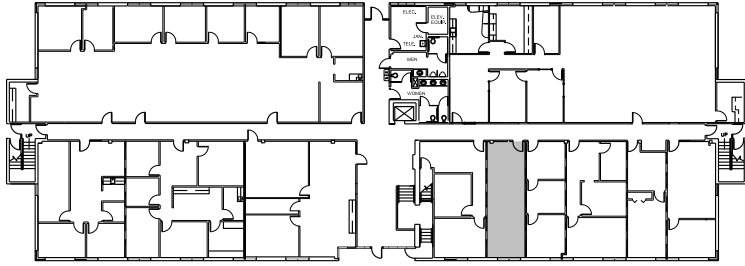

Building
10

Matt Frizzell
E matt.frizzell@cushwake.com
T +1 512 814 3404

Tom Rhea
E tom.rhea@cushwake.com
T +1 512 814 3416

AustinOaks

Suite 152
First floor
504 sf

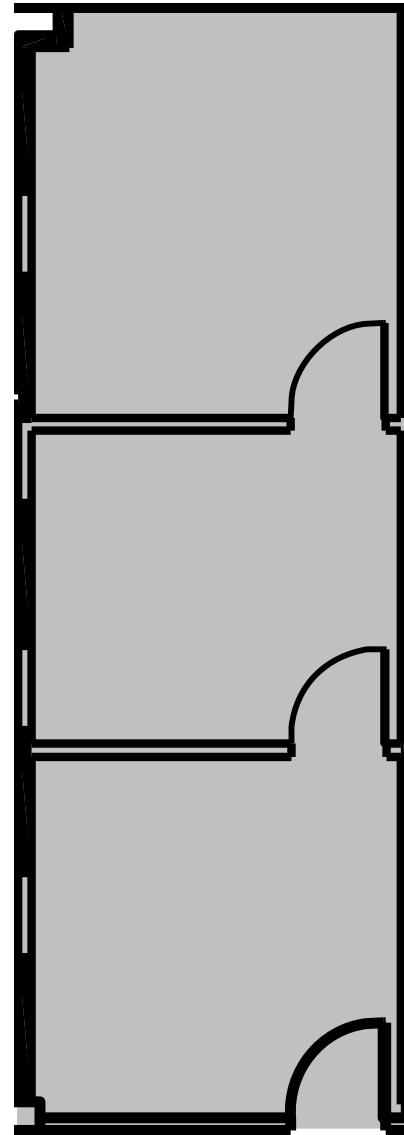
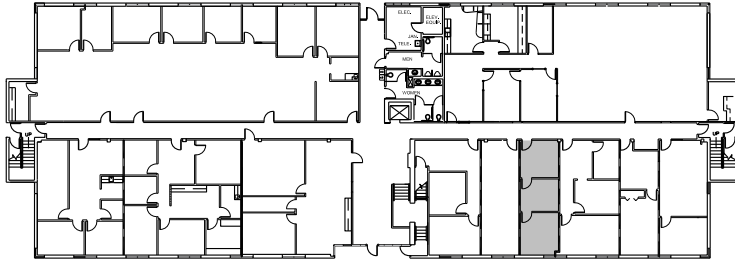

Building
10

Matt Frizzell
E matt.frizzell@cushwake.com
T +1 512 814 3404

Tom Rhea
E tom.rhea@cushwake.com
T +1 512 814 3416

AustinOaks

Suite 120
First floor
513 sf

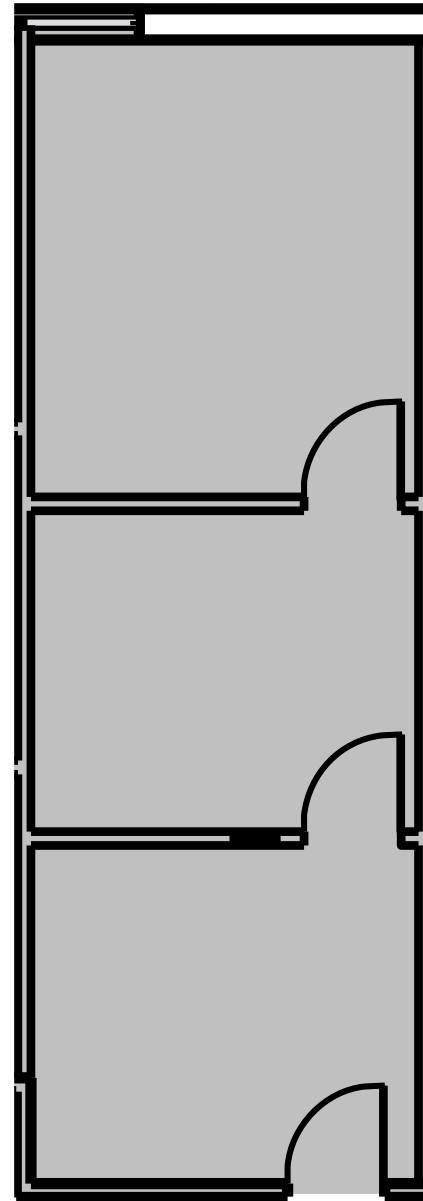
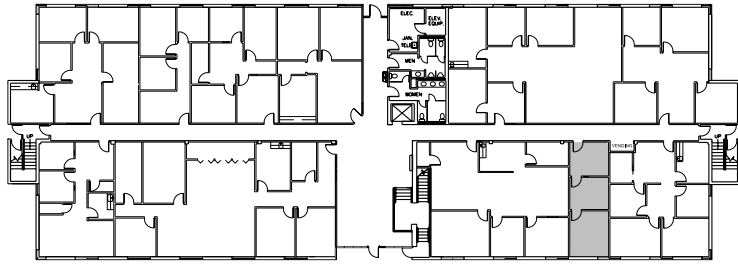

Building
12

Matt Frizzell
E matt.frizzell@cushwake.com
T +1 512 814 3404

Tom Rhea
E tom.rhea@cushwake.com
T +1 512 814 3416

AustinOaks

Suite 158
First floor
624 sf

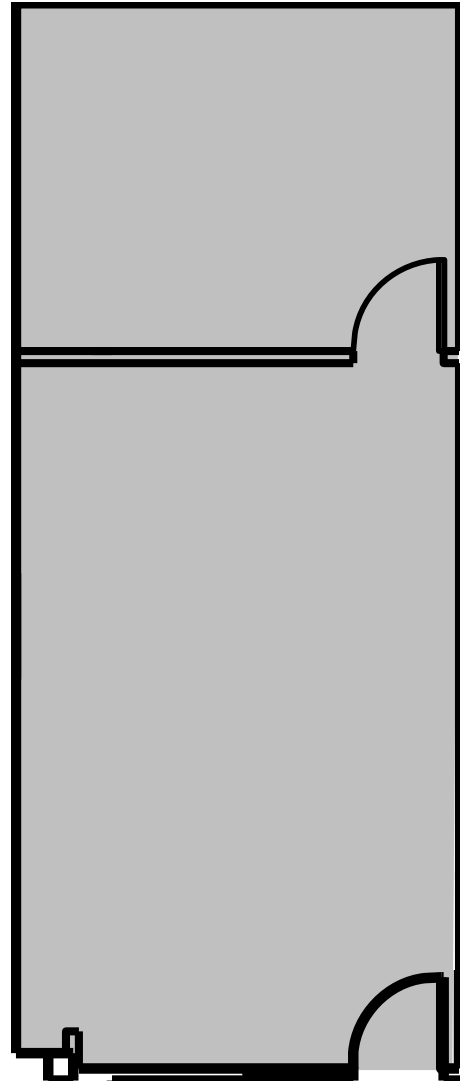
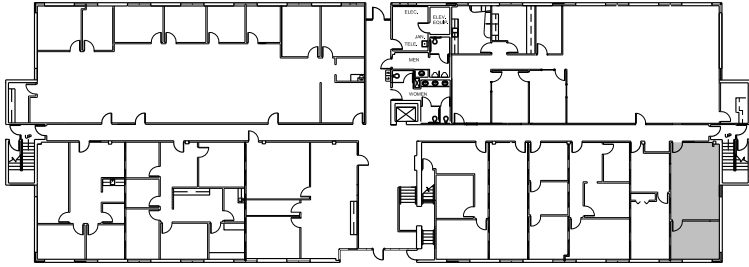

Building

10

Matt Frizzell

E matt.frizzell@cushwake.com

T +1 512 814 3404

Tom Rhea

E tom.rhea@cushwake.com

T +1 512 814 3416

AustinOaks

Suite 108
First floor
740 sf

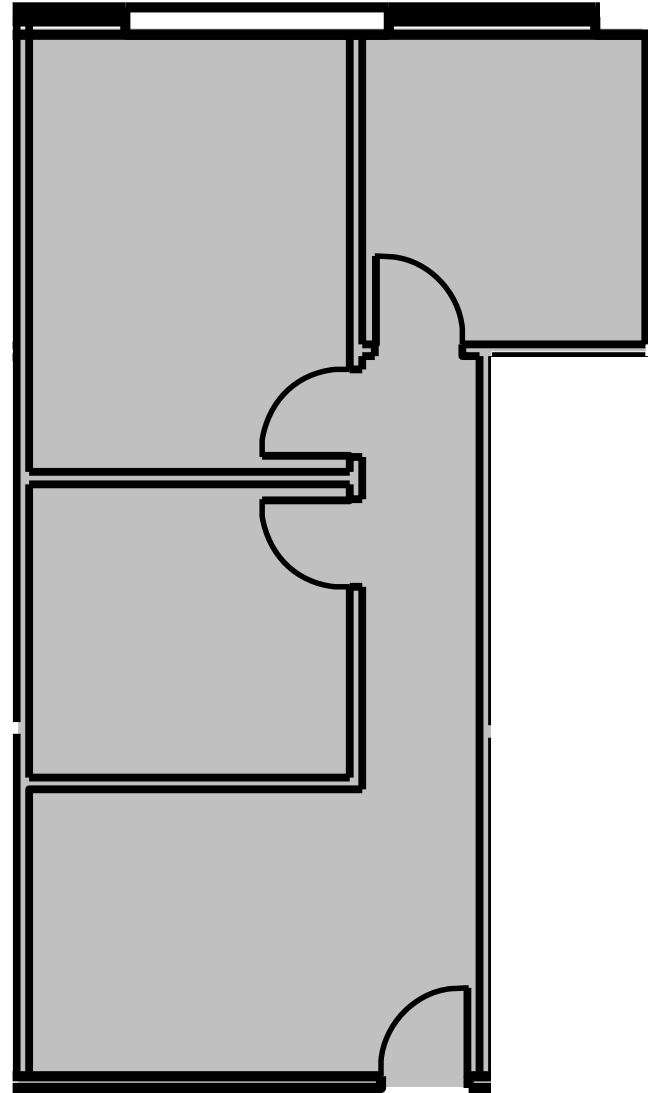
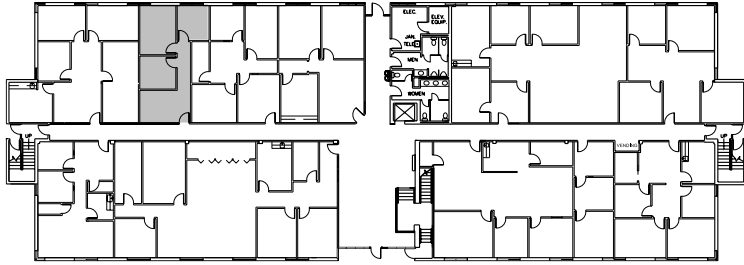

Building
12

Matt Frizzell
E matt.frizzell@cushwake.com
T +1 512 814 3404

Tom Rhea
E tom.rhea@cushwake.com
T +1 512 814 3416

AustinOaks

Suite 207
Second floor
761 sf

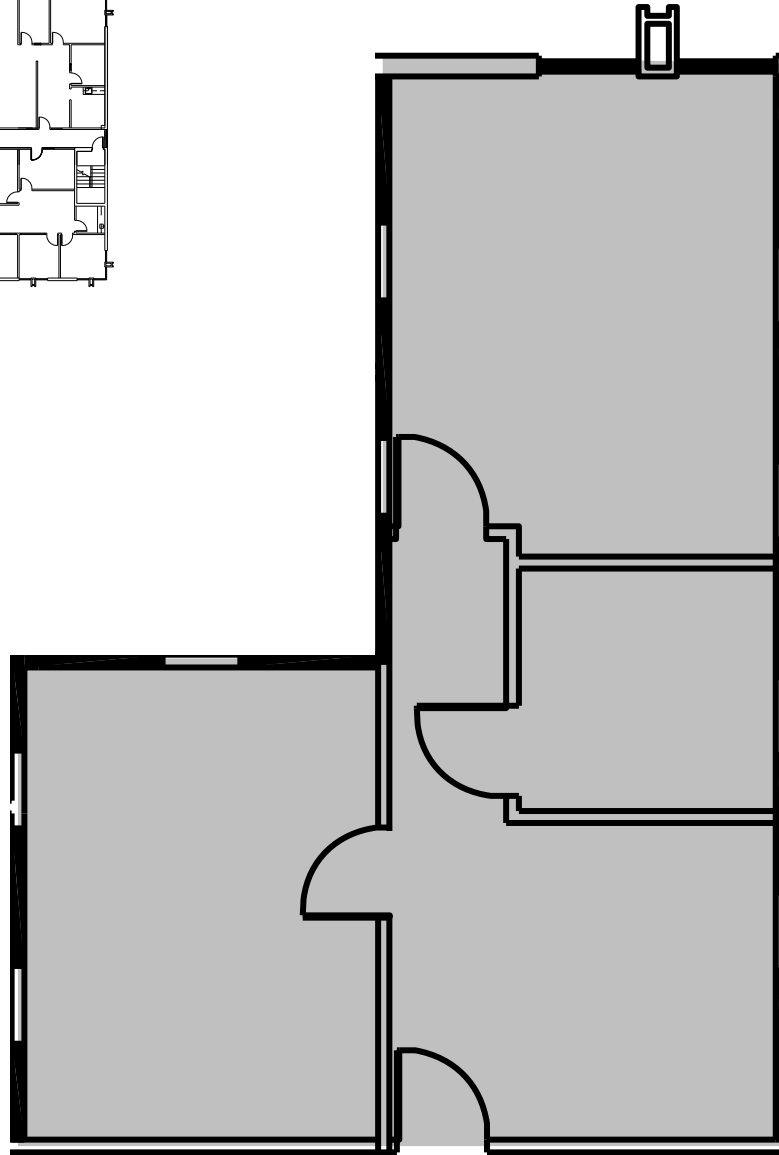
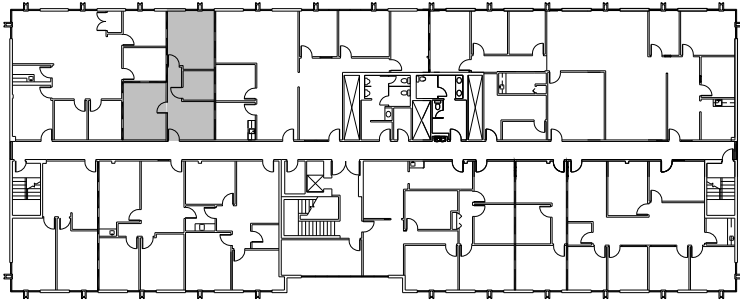

Matt Frizzell

E matt.frizzell@cushwake.com

T +1 512 814 3404

Tom Rhea

E tom.rhea@cushwake.com

T +1 512 814 3416

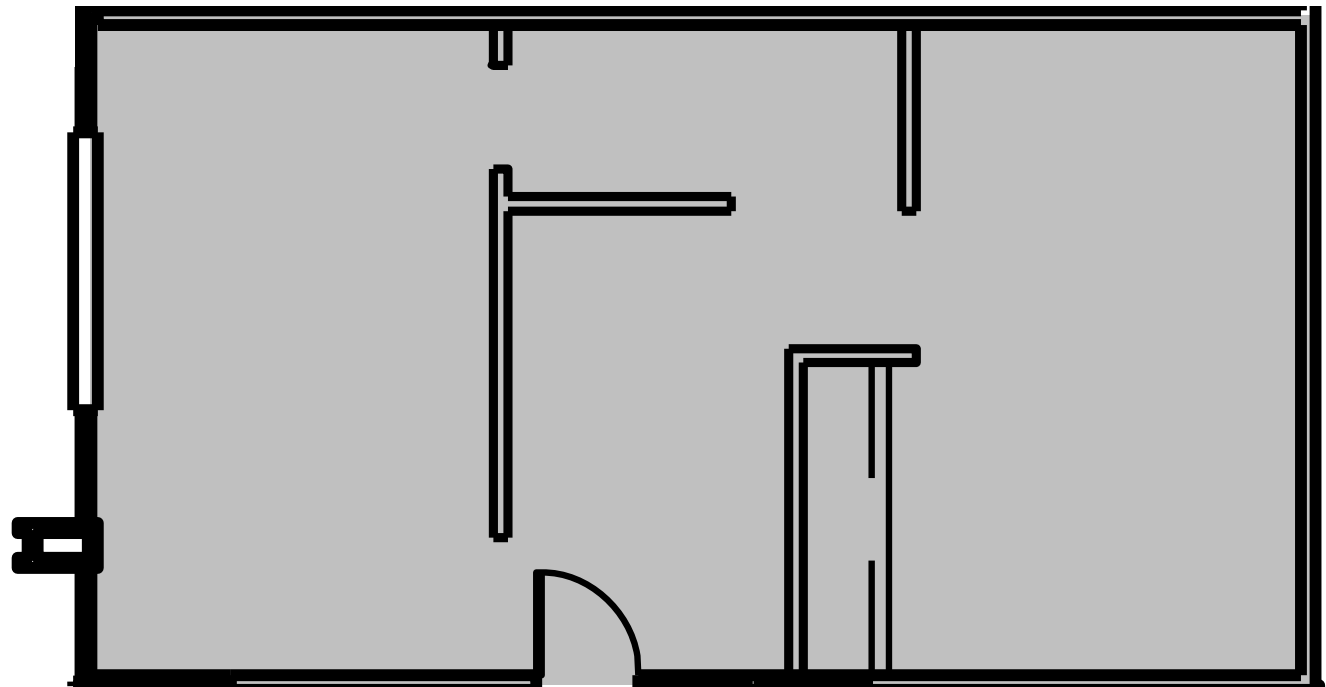
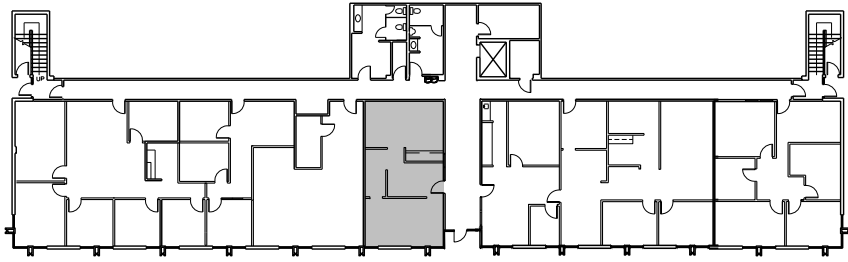

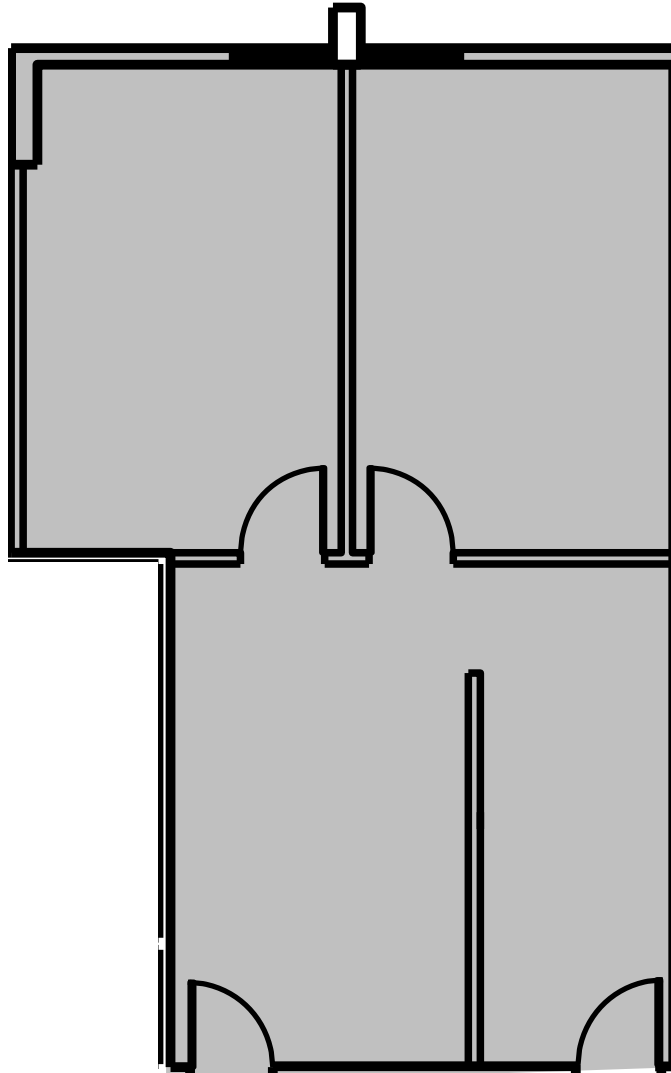
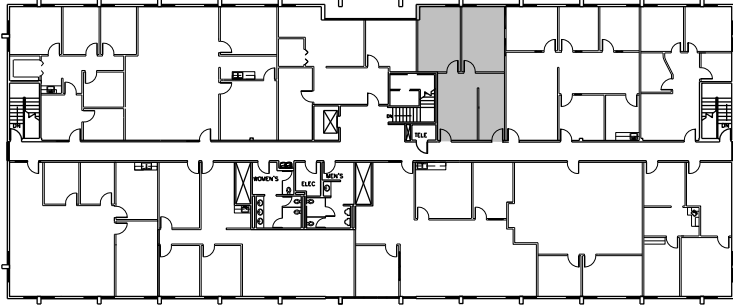

AustinOaks

Suite 216
Second floor
883 sf

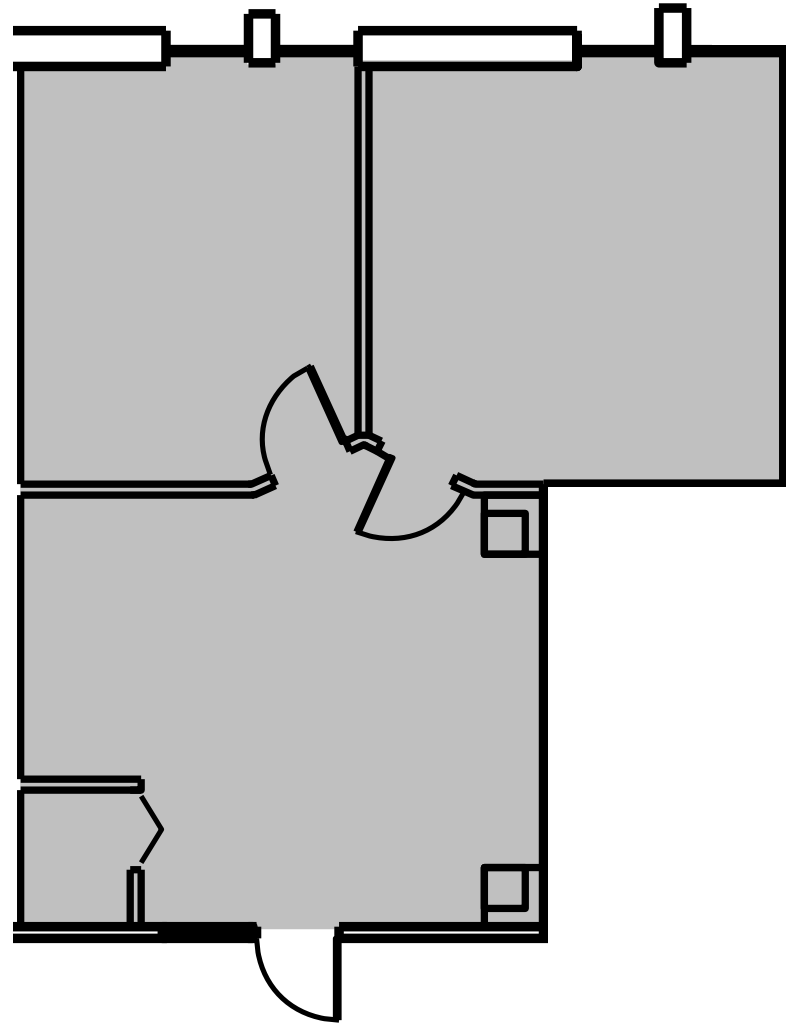
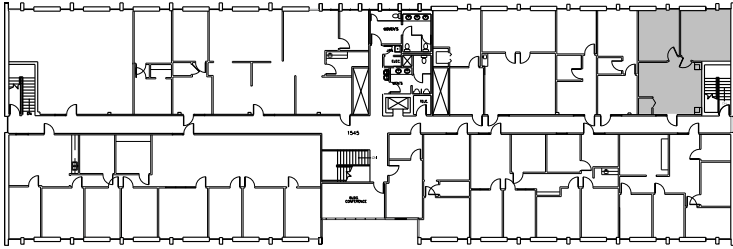

Building

1

Matt Frizzell

E matt.frizzell@cushwake.com

T +1 512 814 3404

Tom Rhea

E tom.rhea@cushwake.com

T +1 512 814 3416

AustinOaks

Suite 104
First floor
949 sf

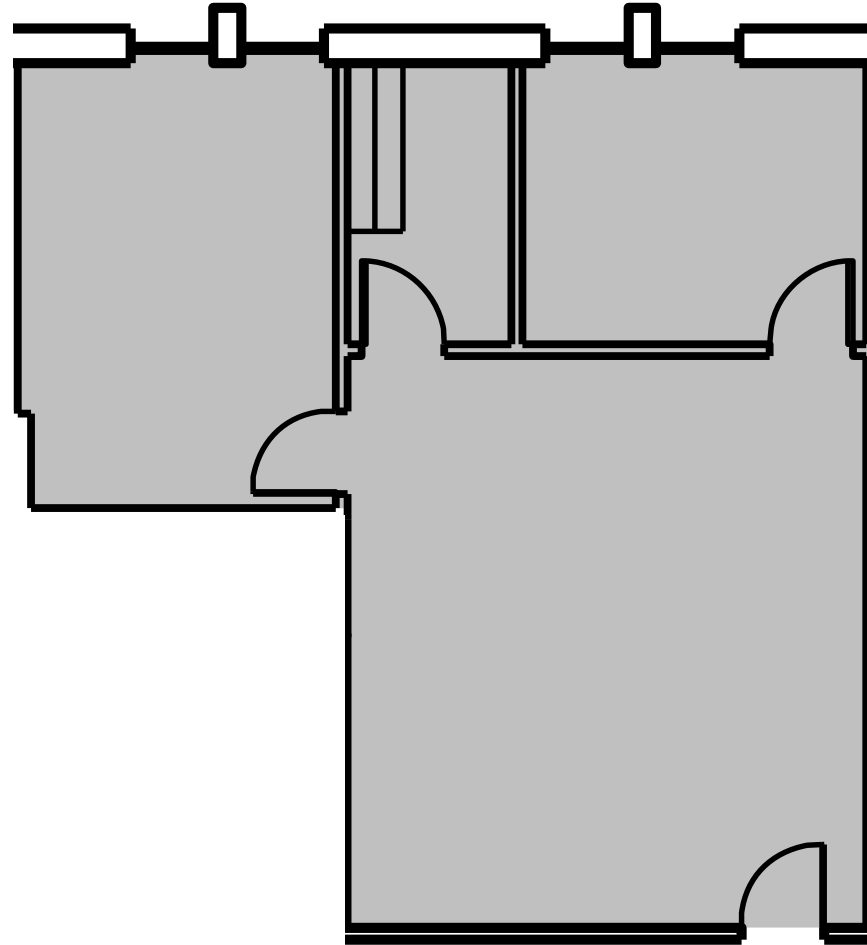
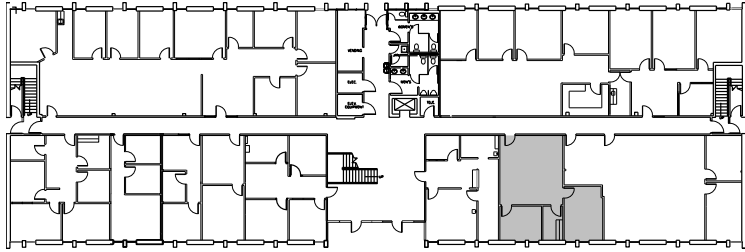

Matt Frizzell
E matt.frizzell@cushwake.com
T +1 512 814 3404

Tom Rhea
E tom.rhea@cushwake.com
T +1 512 814 3416

AustinOaks

Suite 201
Second floor
1,033 sf

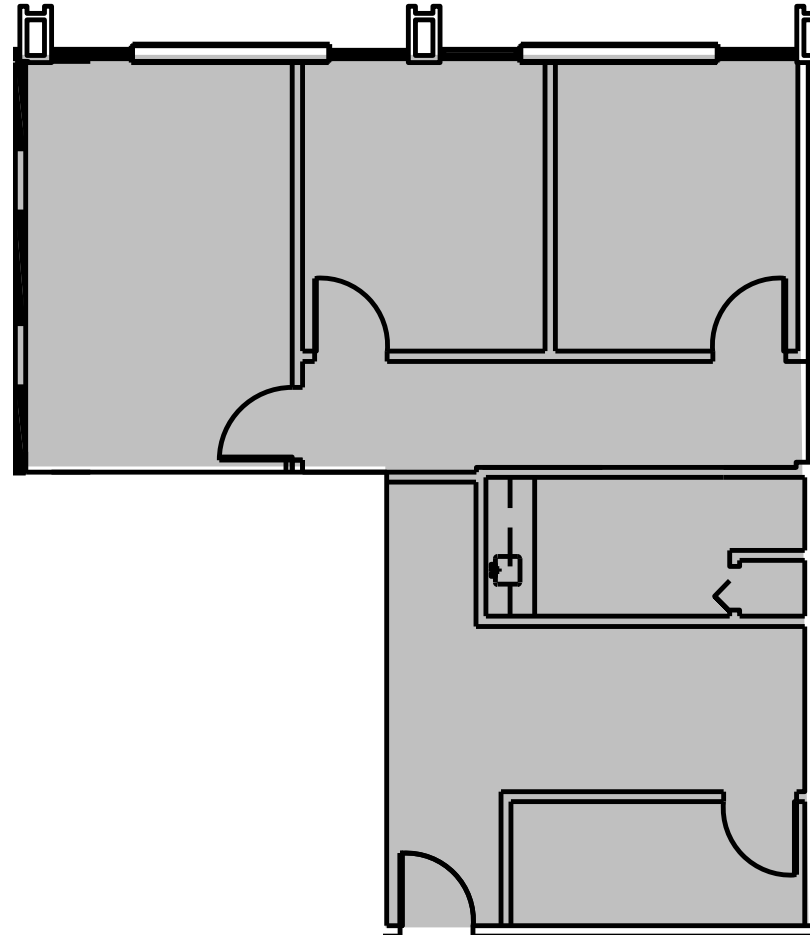

Matt Frizzell

E matt.frizzell@cushwake.com

T +1 512 814 3404

Tom Rhea

E tom.rhea@cushwake.com

T +1 512 814 3416

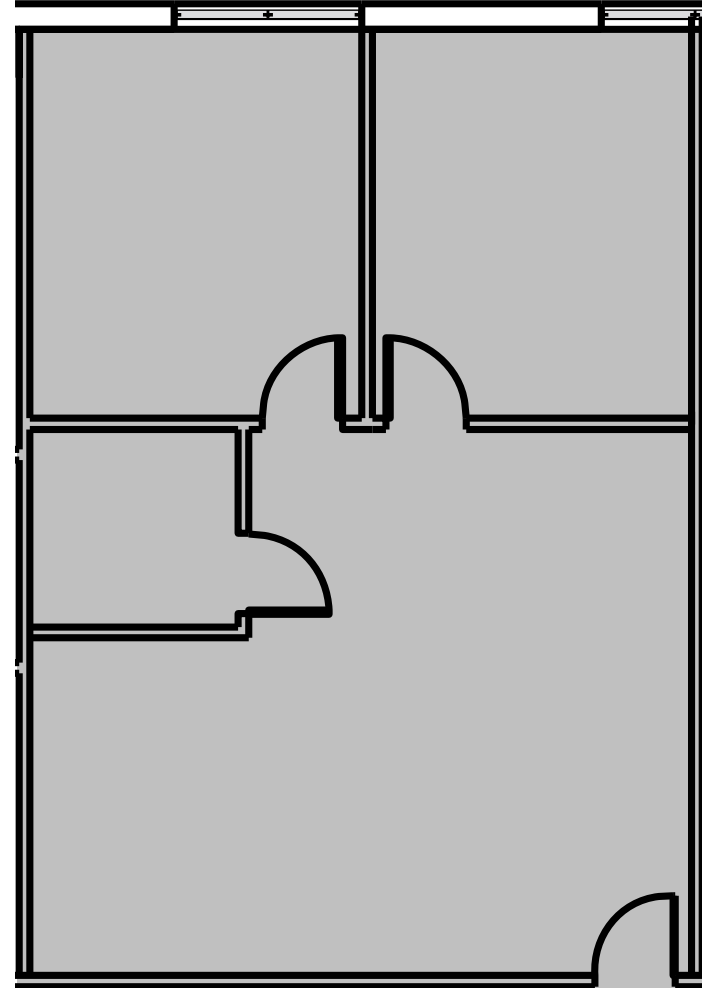
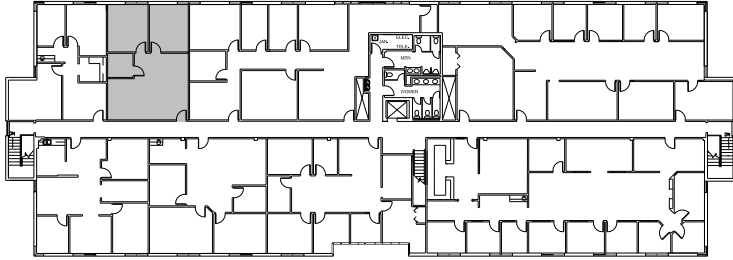

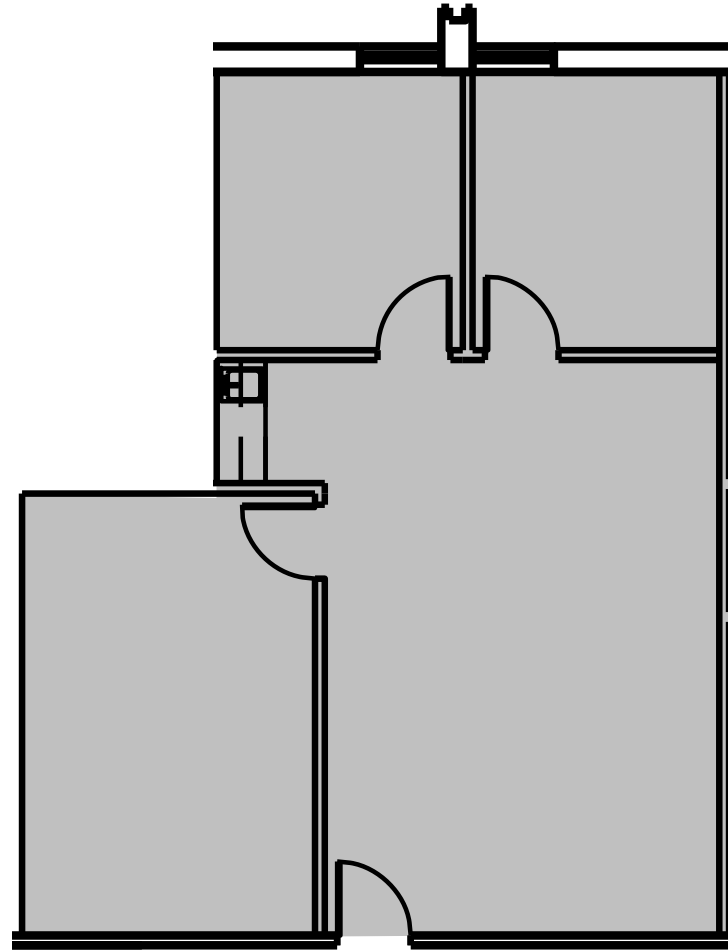
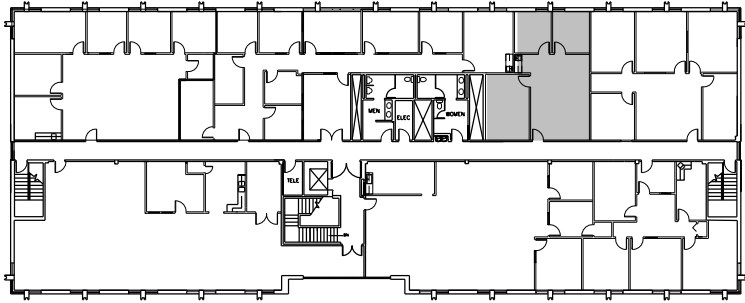

Matt Frizzell

E matt.frizzell@cushwake.com

T +1 512 814 3404

Tom Rhea

E tom.rhea@cushwake.com

T +1 512 814 3416

AustinOaks

Suite 108
First floor
1,099 sf

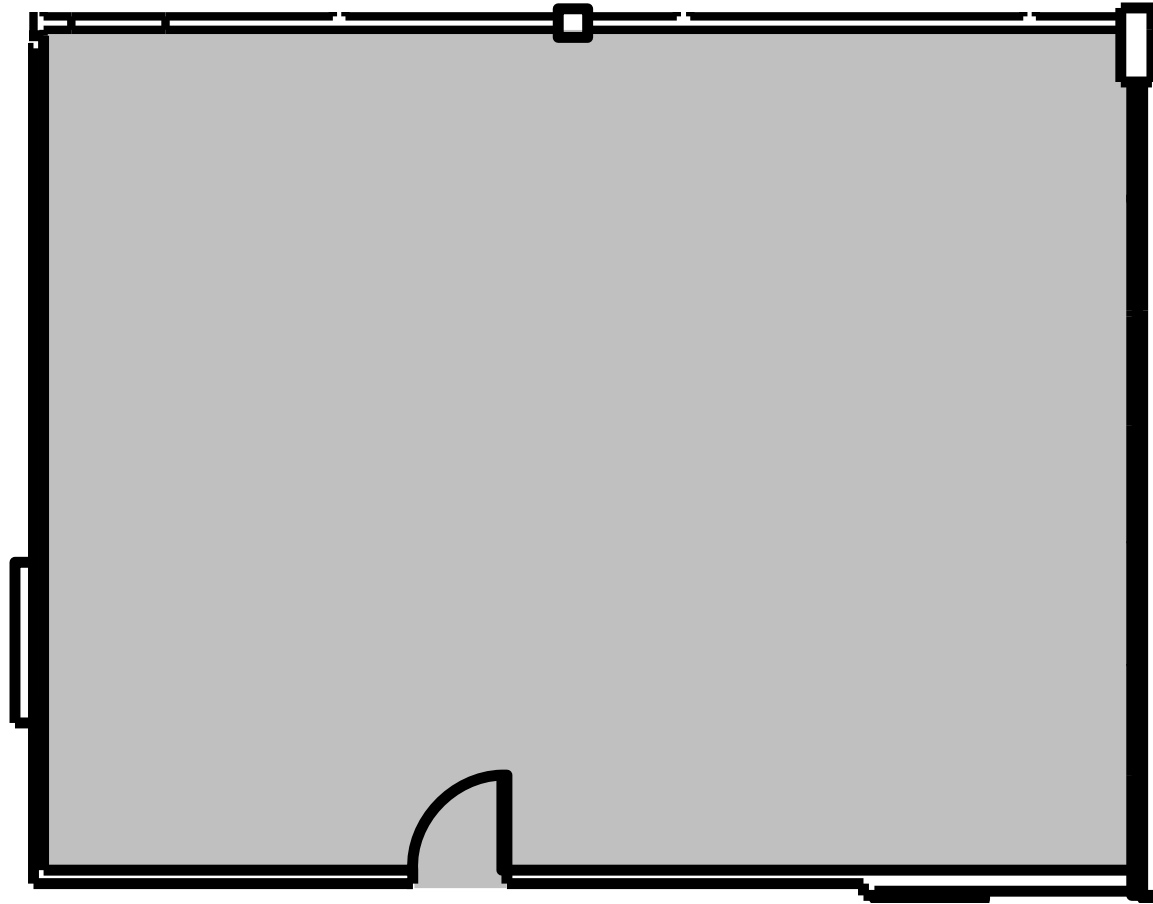
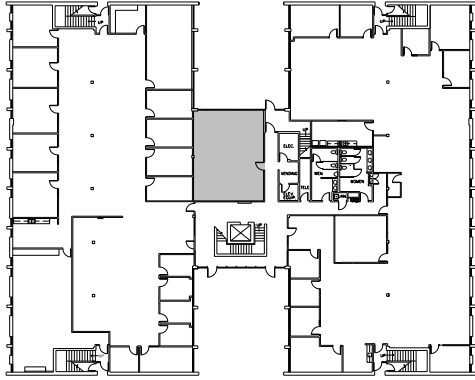

Matt Frizzell
E matt.frizzell@cushwake.com
T +1 512 814 3404

Tom Rhea
E tom.rhea@cushwake.com
T +1 512 814 3416

AustinOaks

Suite 120
First floor
1,127 sf

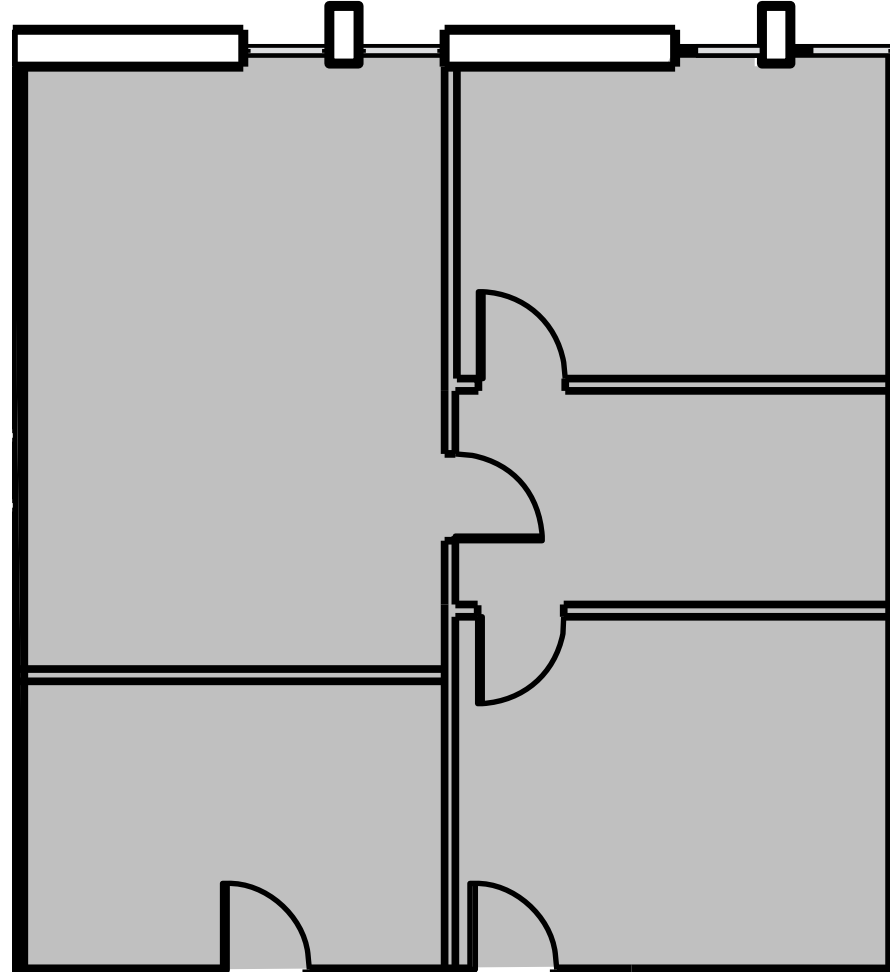
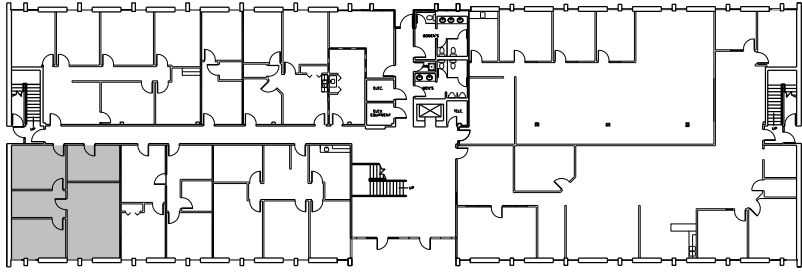

Matt Frizzell
E matt.frizzell@cushwake.com
T +1 512 814 3404

Tom Rhea
E tom.rhea@cushwake.com
T +1 512 814 3416

AustinOaks

Suite 215
Second floor
1,251 sf

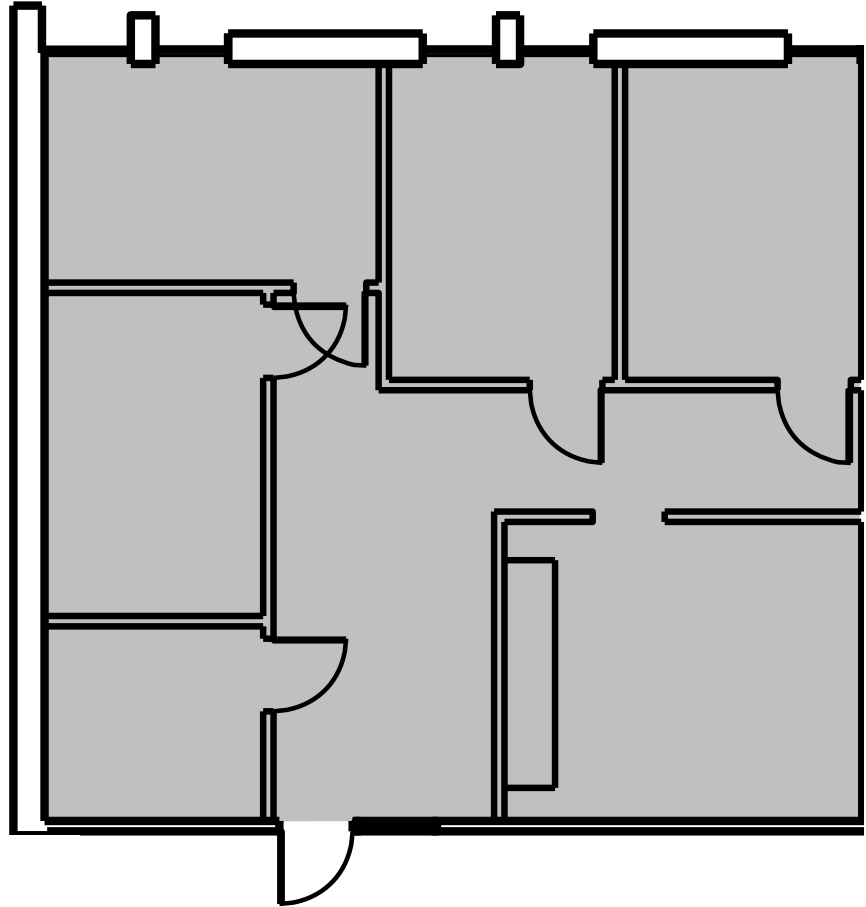
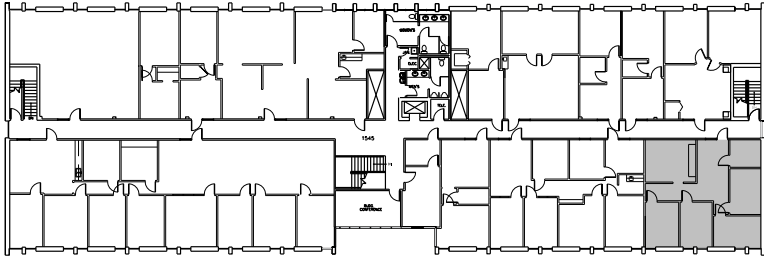

Matt Frizzell

E matt.frizzell@cushwake.com

T +1 512 814 3404

Tom Rhea

E tom.rhea@cushwake.com

T +1 512 814 3416

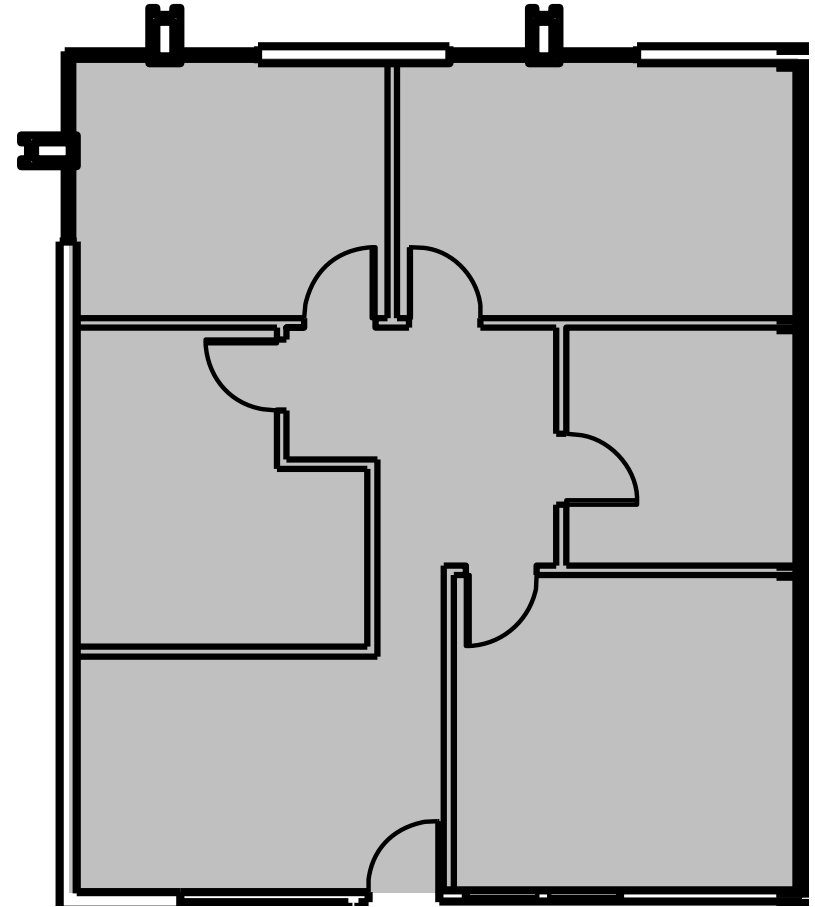
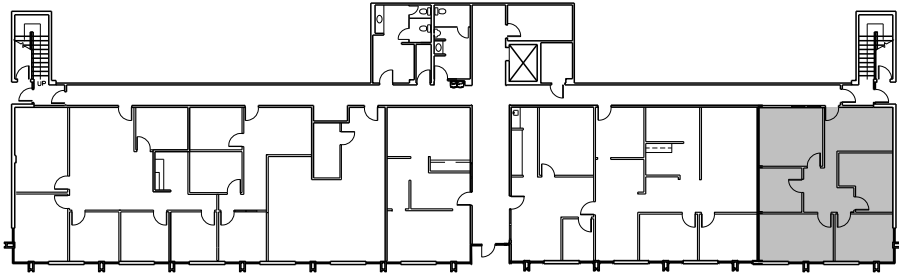

Matt Frizzell

E matt.frizzell@cushwake.com

T +1 512 814 3404

Tom Rhea

E tom.rhea@cushwake.com

T +1 512 814 3416

AustinOaks

Suite 100
First floor
1,390 sf

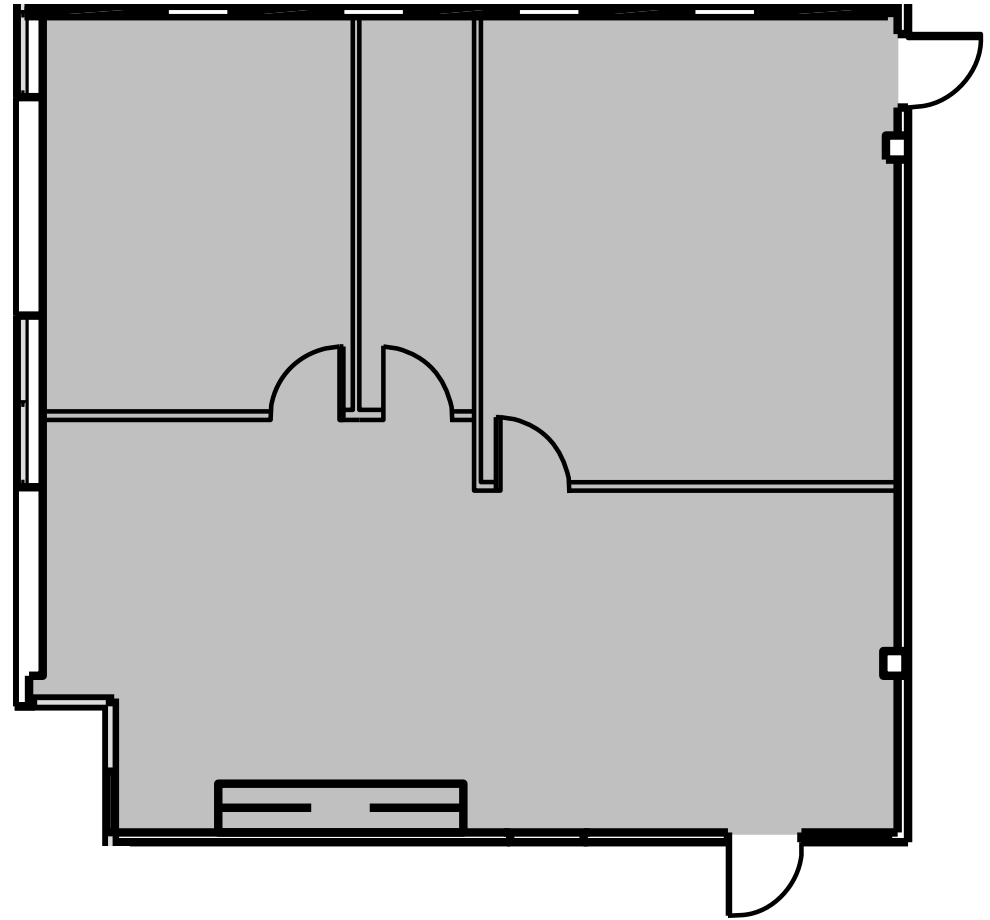
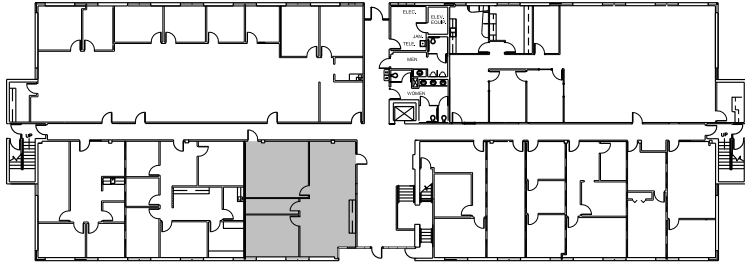

Building
10

Matt Frizzell
E matt.frizzell@cushwake.com
T +1 512 814 3404

Tom Rhea
E tom.rhea@cushwake.com
T +1 512 814 3416

AustinOaks

Suite 100
First floor
1,423 sf

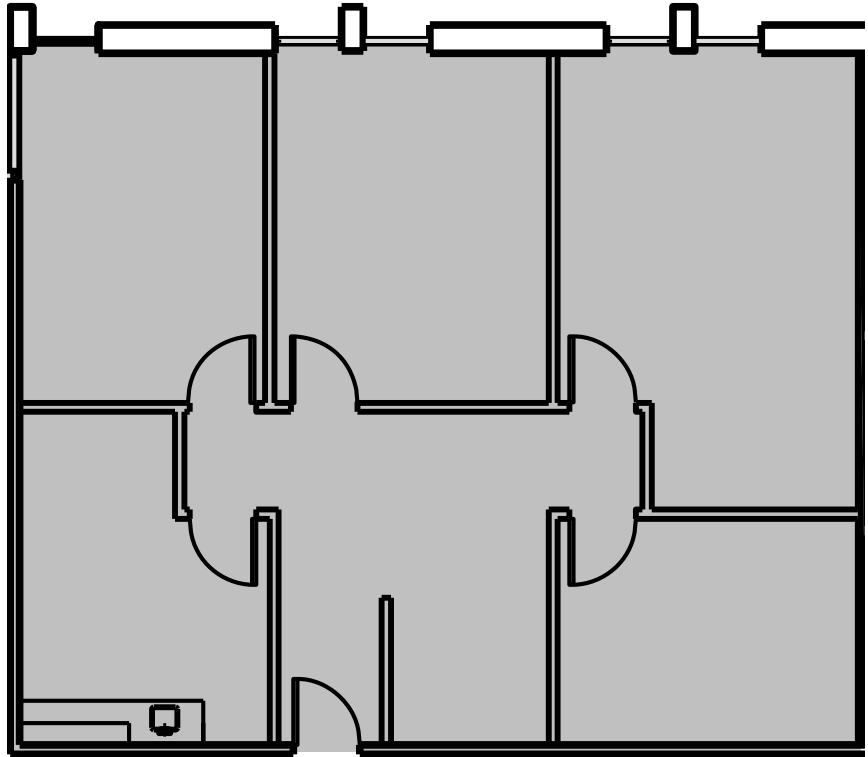
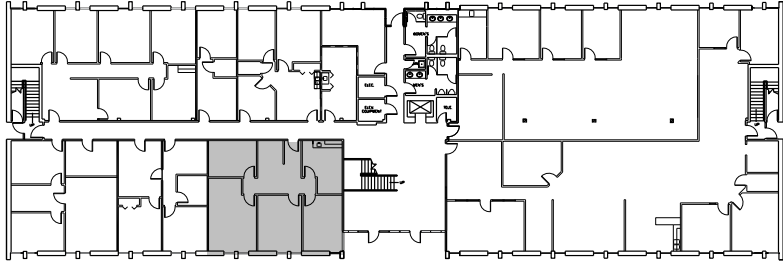

Building

3

Matt Frizzell

E matt.frizzell@cushwake.com

T +1 512 814 3404

Tom Rhea

E tom.rhea@cushwake.com

T +1 512 814 3416

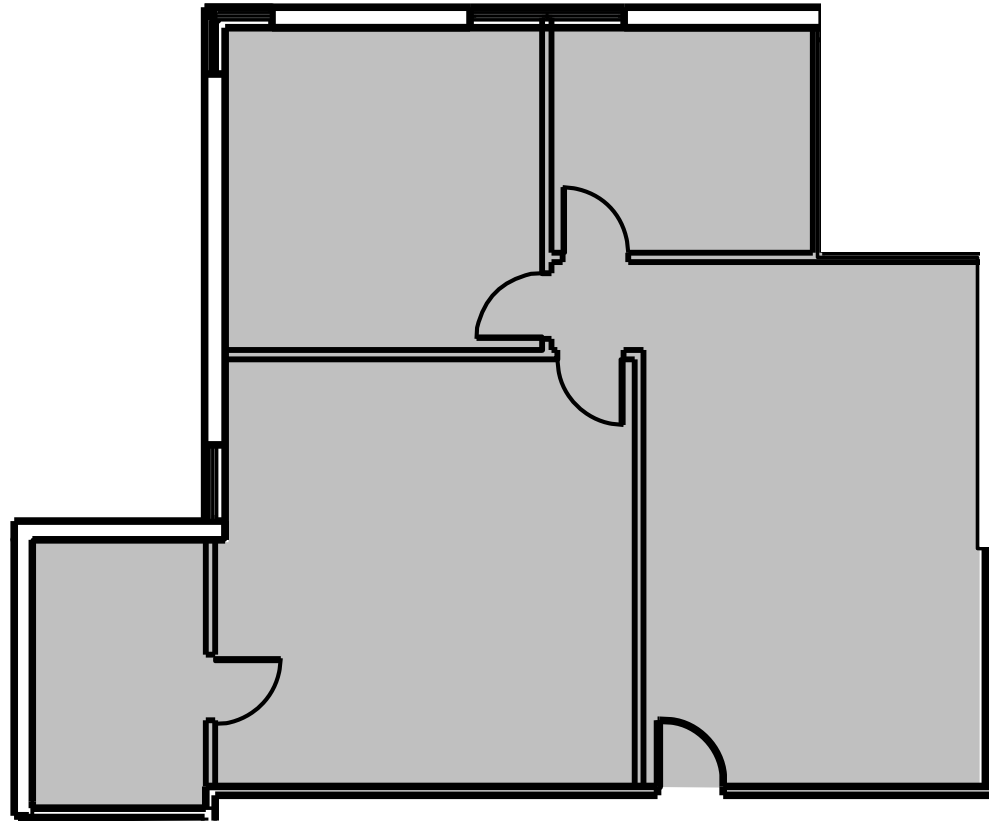
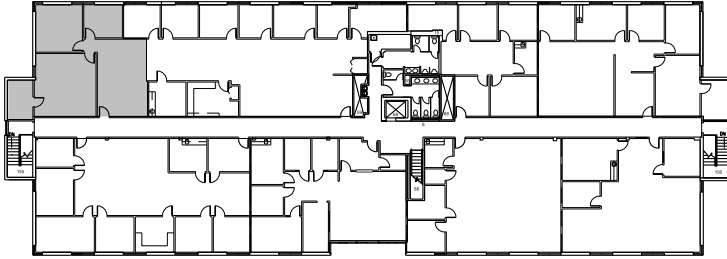

Matt Frizzell

E matt.frizzell@cushwake.com

T +1 512 814 3404

Tom Rhea

E tom.rhea@cushwake.com

T +1 512 814 3416

AustinOaks

Suite 215
Second floor
1,527 sf

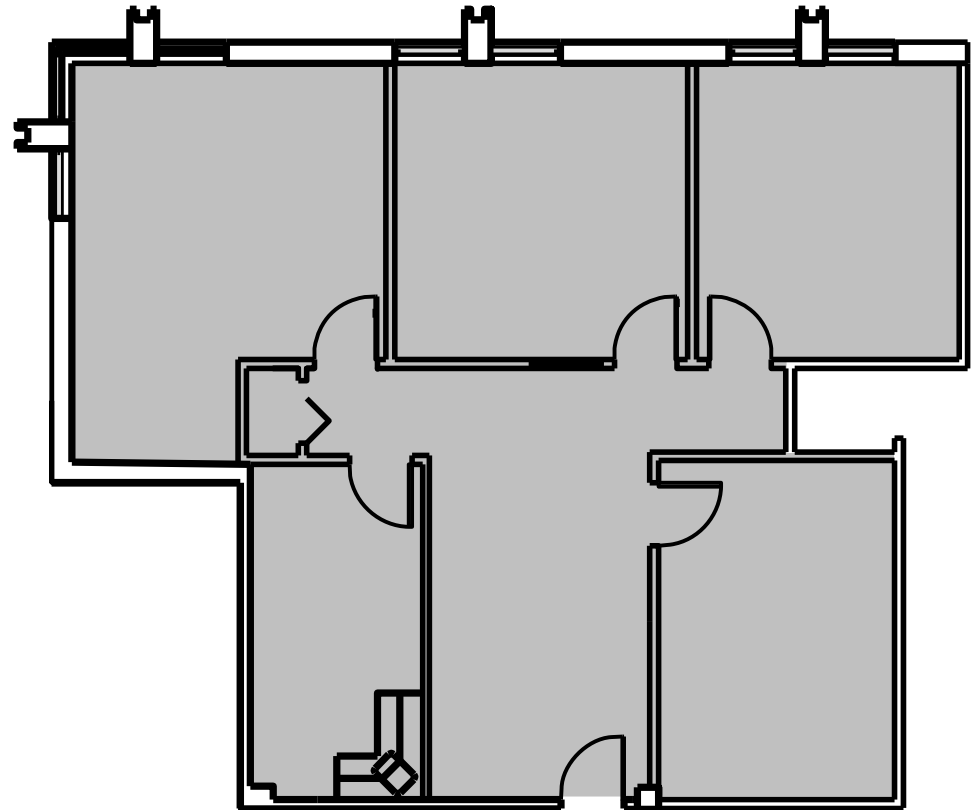
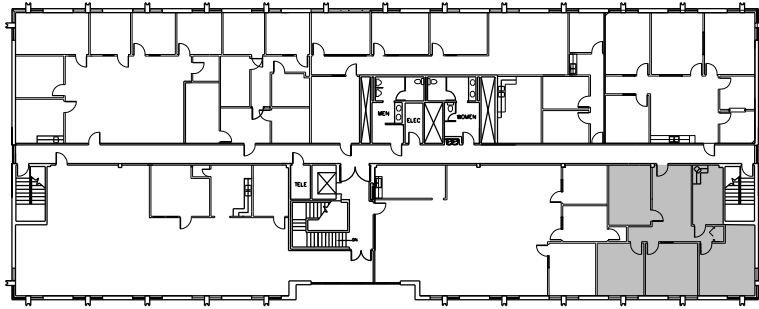

Matt Frizzell
E matt.frizzell@cushwake.com
T +1 512 814 3404

Tom Rhea
E tom.rhea@cushwake.com
T +1 512 814 3416

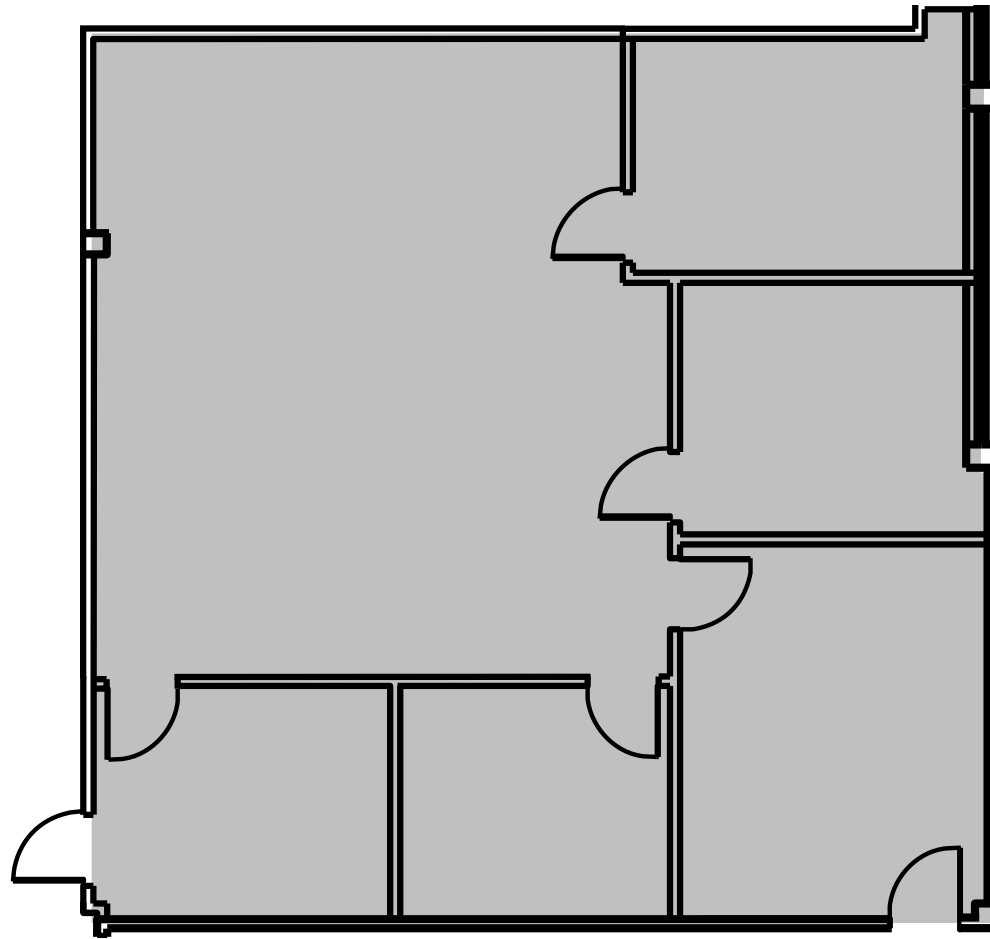
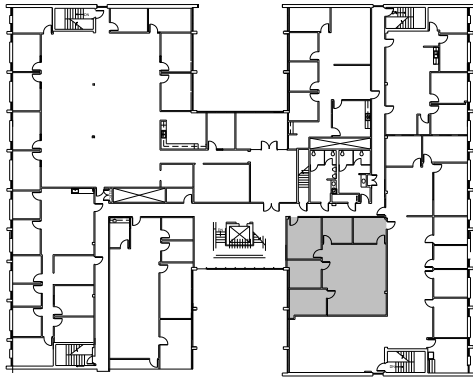

AustinOaks

Suite 202
Second floor
1,688 sf

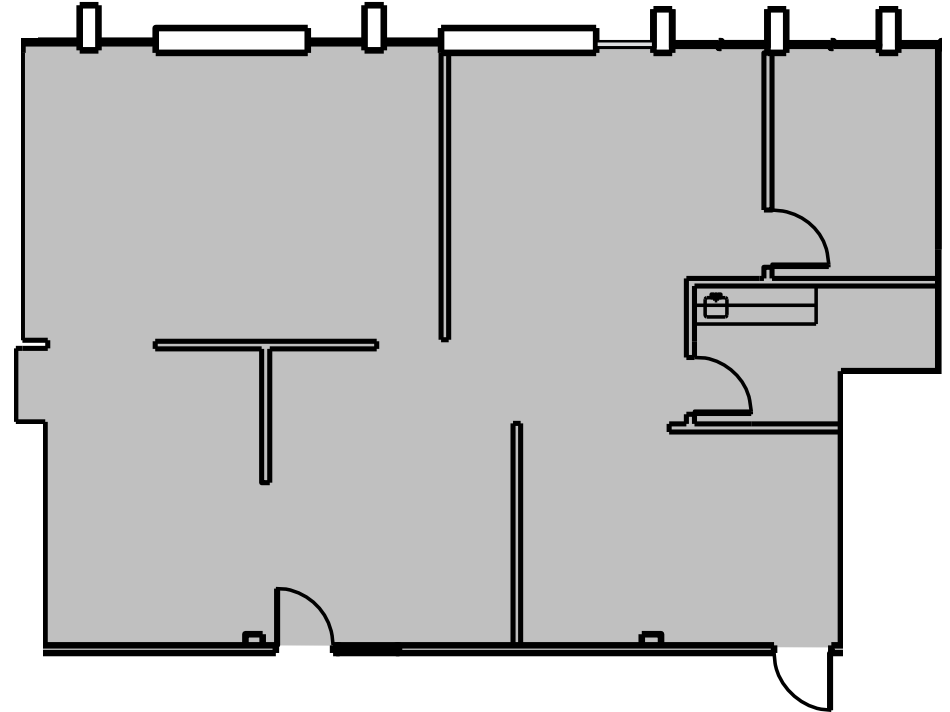
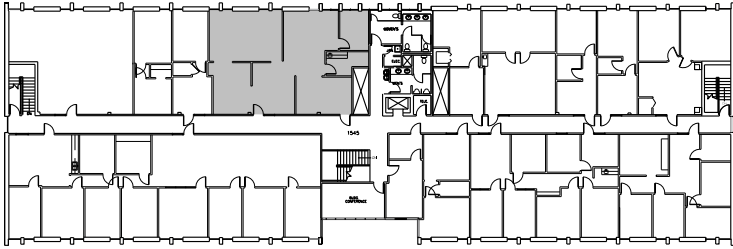

Matt Frizzell

E matt.frizzell@cushwake.com

T +1 512 814 3404

Tom Rhea

E tom.rhea@cushwake.com

T +1 512 814 3416

AustinOaks

Suite 205
Second floor
1,717 sf

Avail. 2.1.20

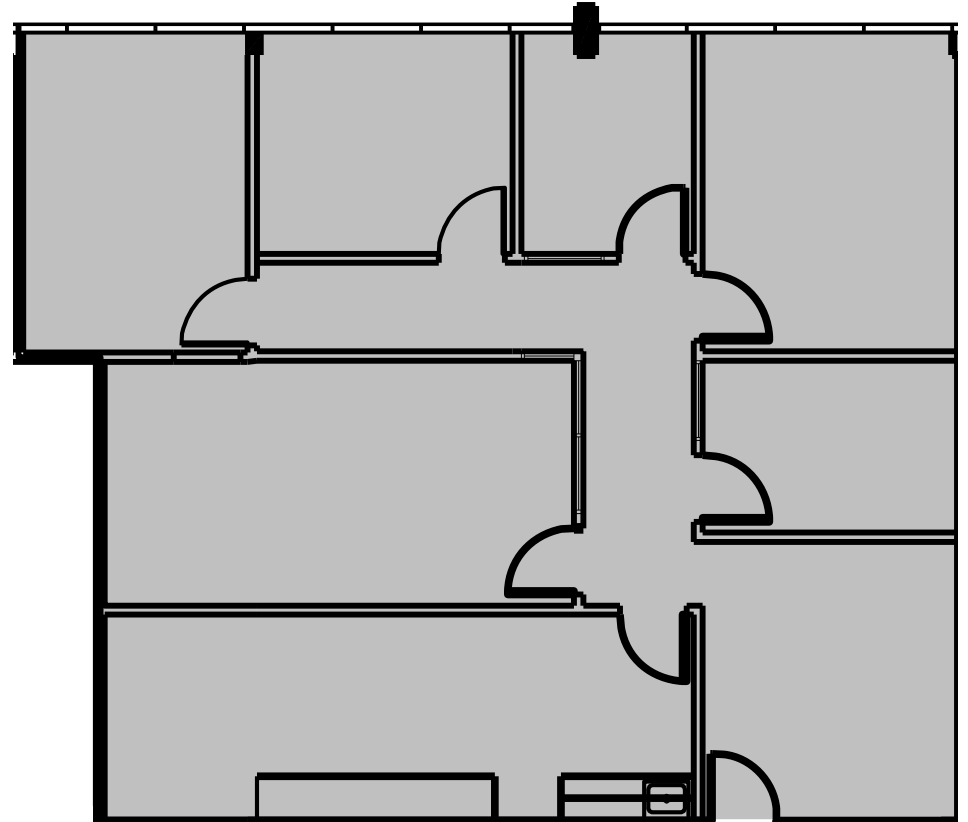
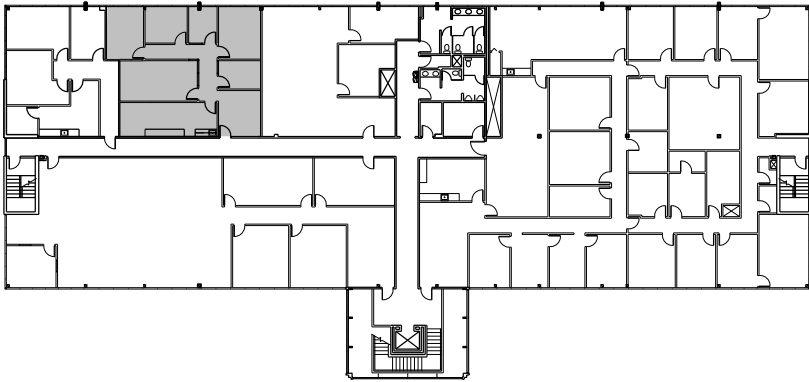

Matt Frizzell

E matt.frizzell@cushwake.com

T +1 512 814 3404

Tom Rhea

E tom.rhea@cushwake.com

T +1 512 814 3416

AustinOaks

Suite 110
First floor
1,725 sf

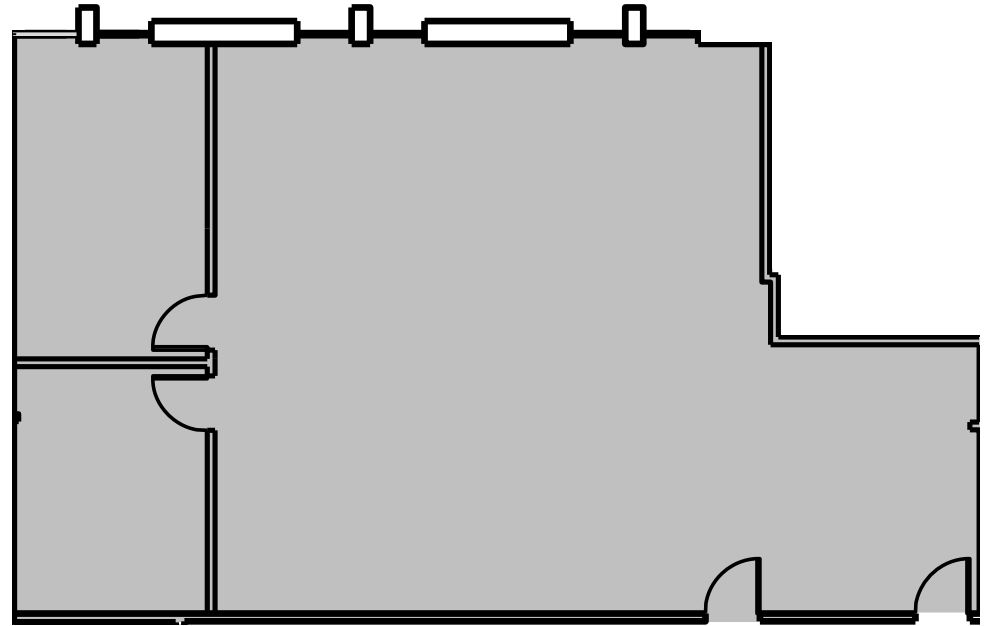
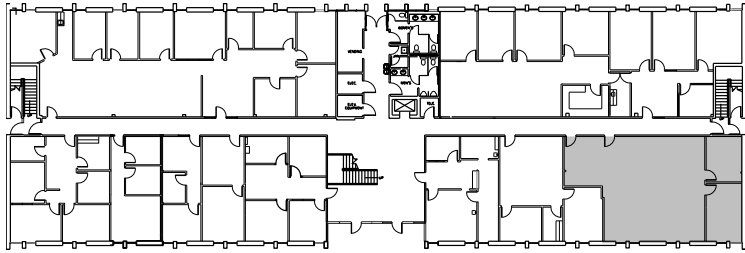

Building

1

Matt Frizzell

E matt.frizzell@cushwake.com

T +1 512 814 3404

Tom Rhea

E tom.rhea@cushwake.com

T +1 512 814 3416

AustinOaks

Suite 150
First floor
1,812 sf

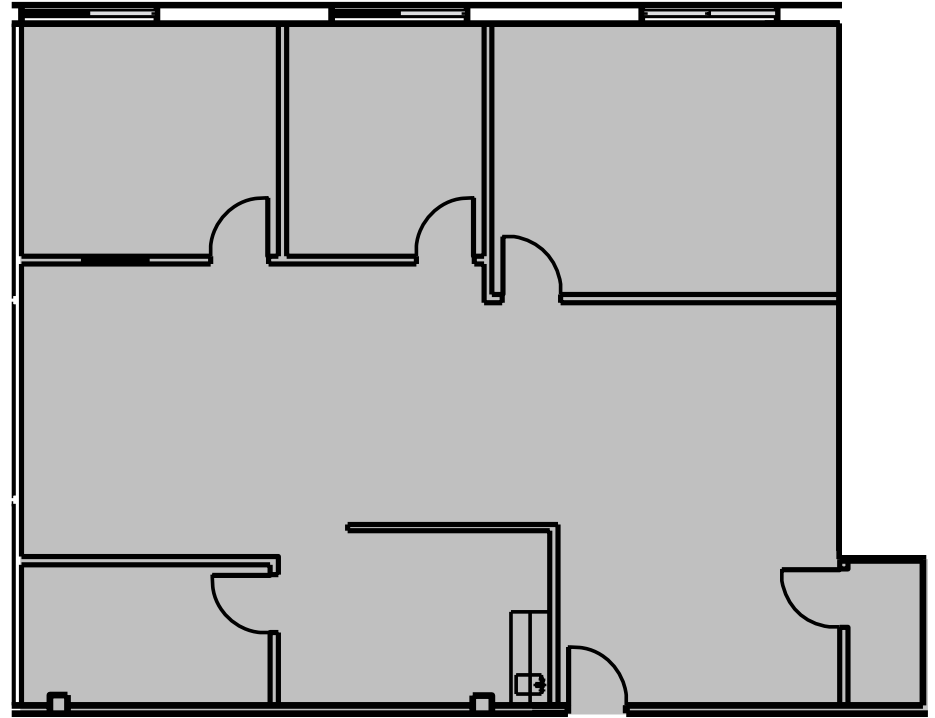
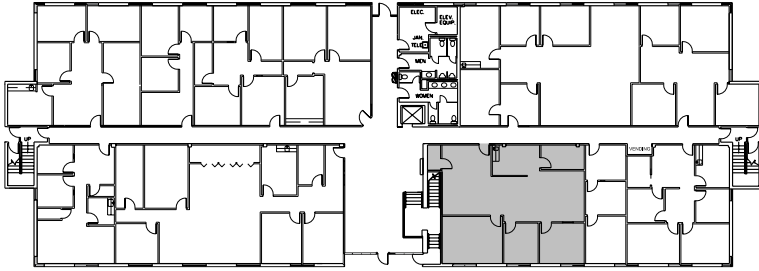

Matt Frizzell
E matt.frizzell@cushwake.com
T +1 512 814 3404

Tom Rhea
E tom.rhea@cushwake.com
T +1 512 814 3416

AustinOaks

Suite 158
First floor
1,816 sf

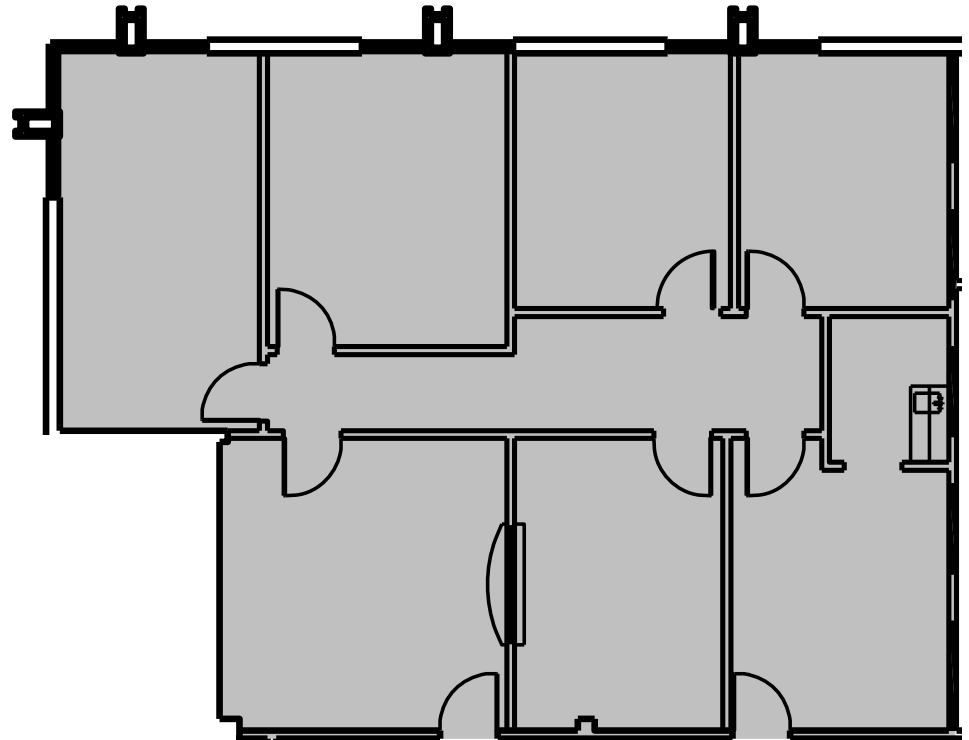
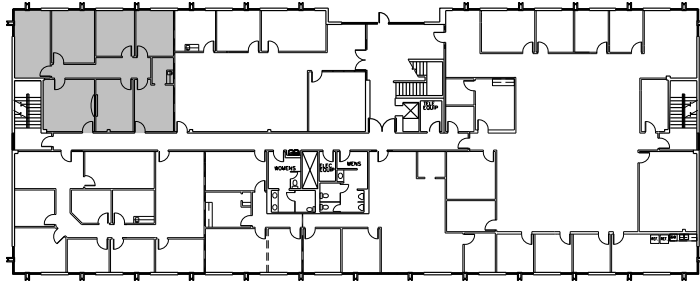

Matt Frizzell
E matt.frizzell@cushwake.com
T +1 512 814 3404

Tom Rhea
E tom.rhea@cushwake.com
T +1 512 814 3416

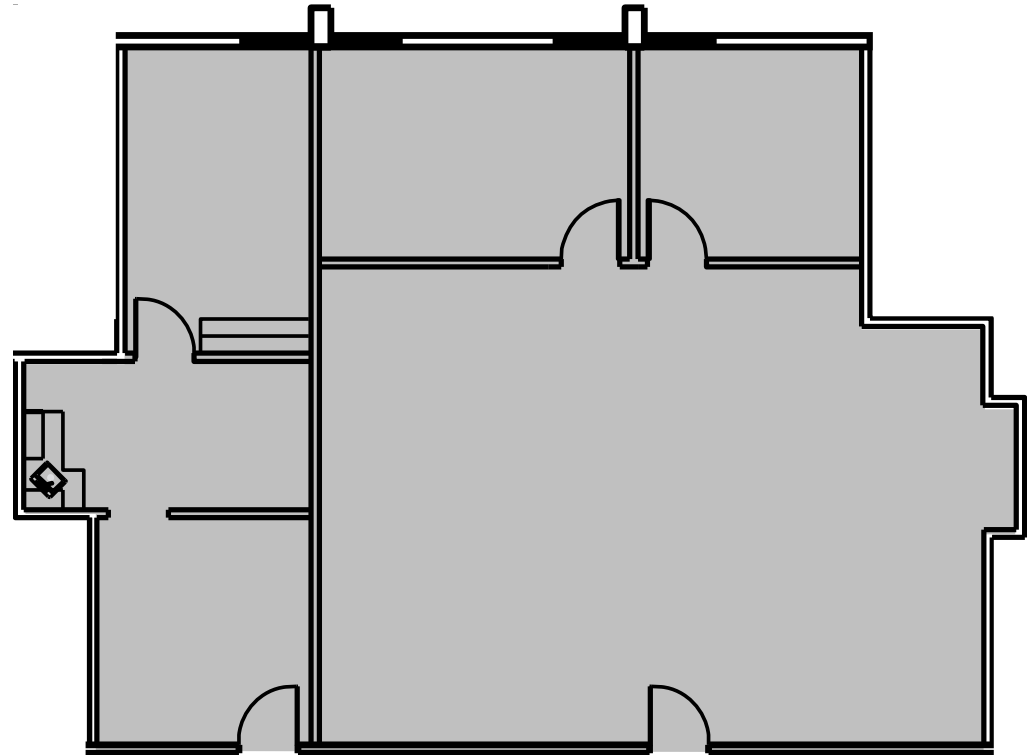
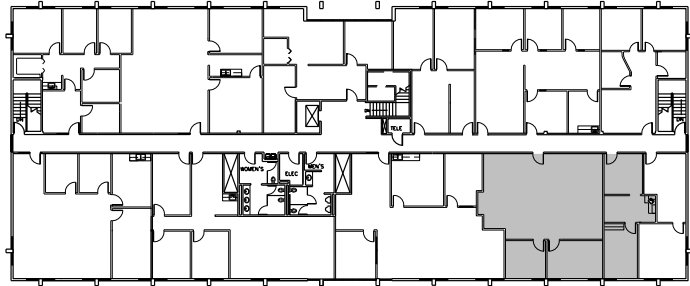

Matt Frizzell

E matt.frizzell@cushwake.com

T +1 512 814 3404

Tom Rhea

E tom.rhea@cushwake.com

T +1 512 814 3416

AustinOaks

Suite 152
First floor
2,008 sf

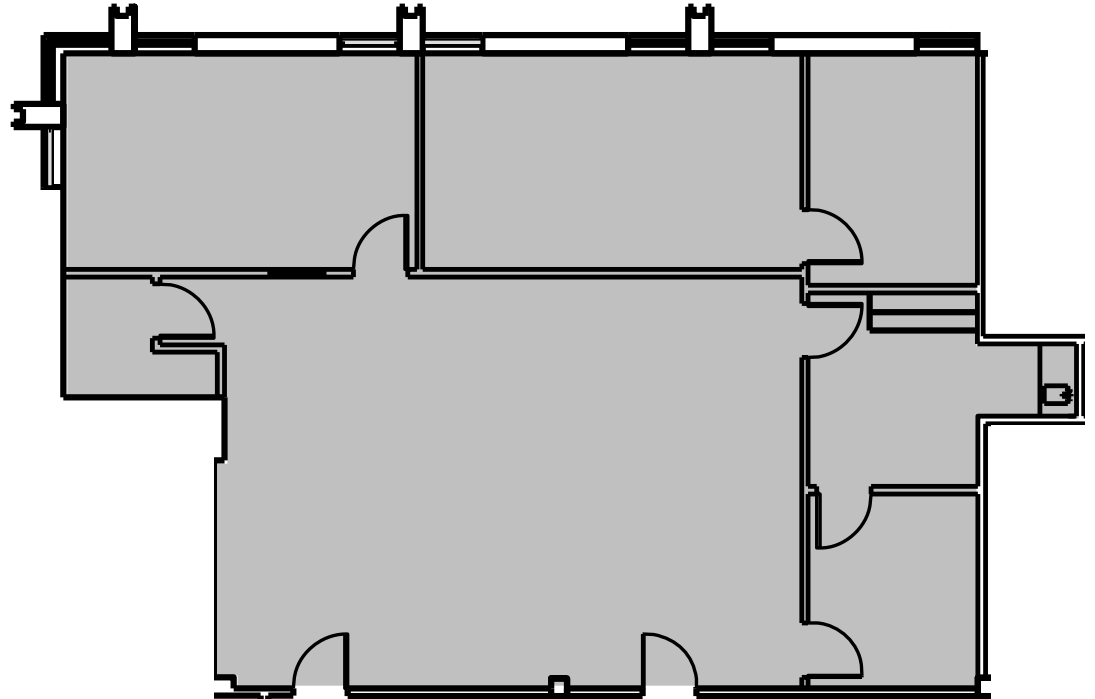
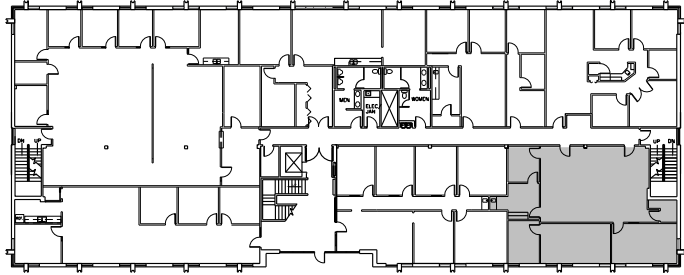

Matt Frizzell
E matt.frizzell@cushwake.com
T +1 512 814 3404

Tom Rhea
E tom.rhea@cushwake.com
T +1 512 814 3416

AustinOaks

Suite 150
First floor
2,064 sf

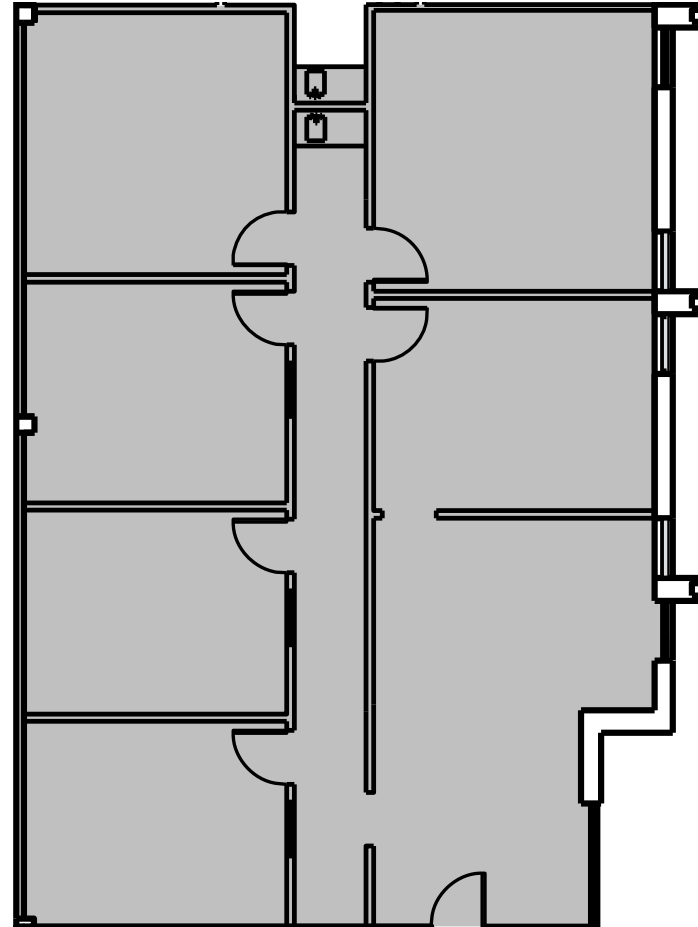
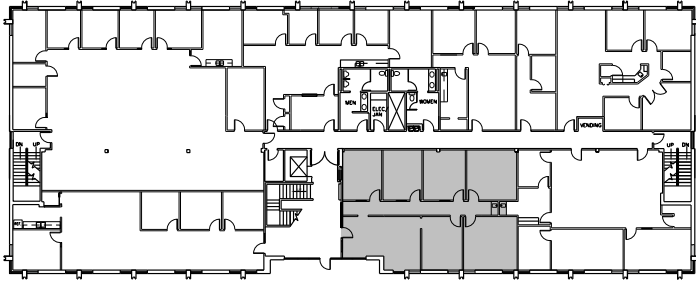

Matt Frizzell
E matt.frizzell@cushwake.com
T +1 512 814 3404

Tom Rhea
E tom.rhea@cushwake.com
T +1 512 814 3416

AustinOaks

Suite 205
Second floor
2,078 sf

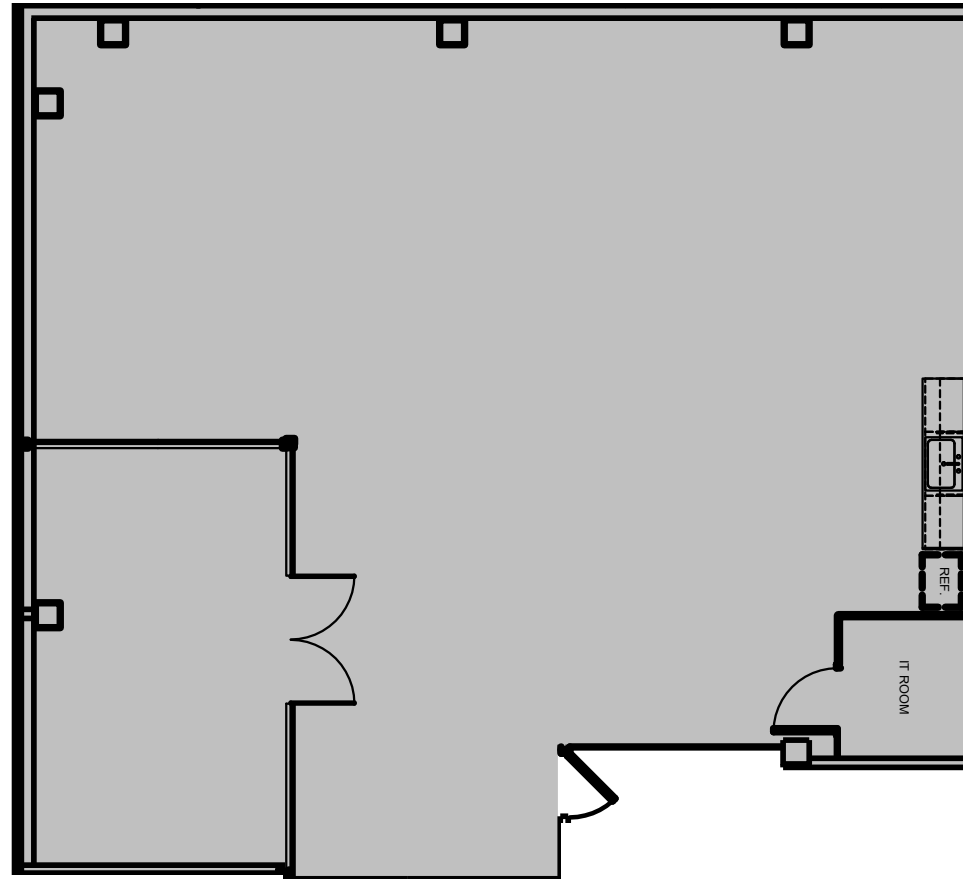
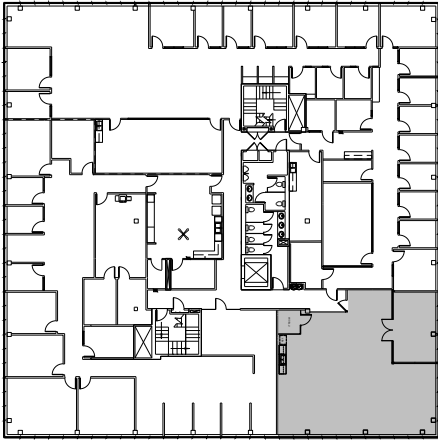

Building

4

Matt Frizzell

E matt.frizzell@cushwake.com

T +1 512 814 3404

Tom Rhea

E tom.rhea@cushwake.com

T +1 512 814 3416

AustinOaks

Suite 159
First floor
2,117 sf

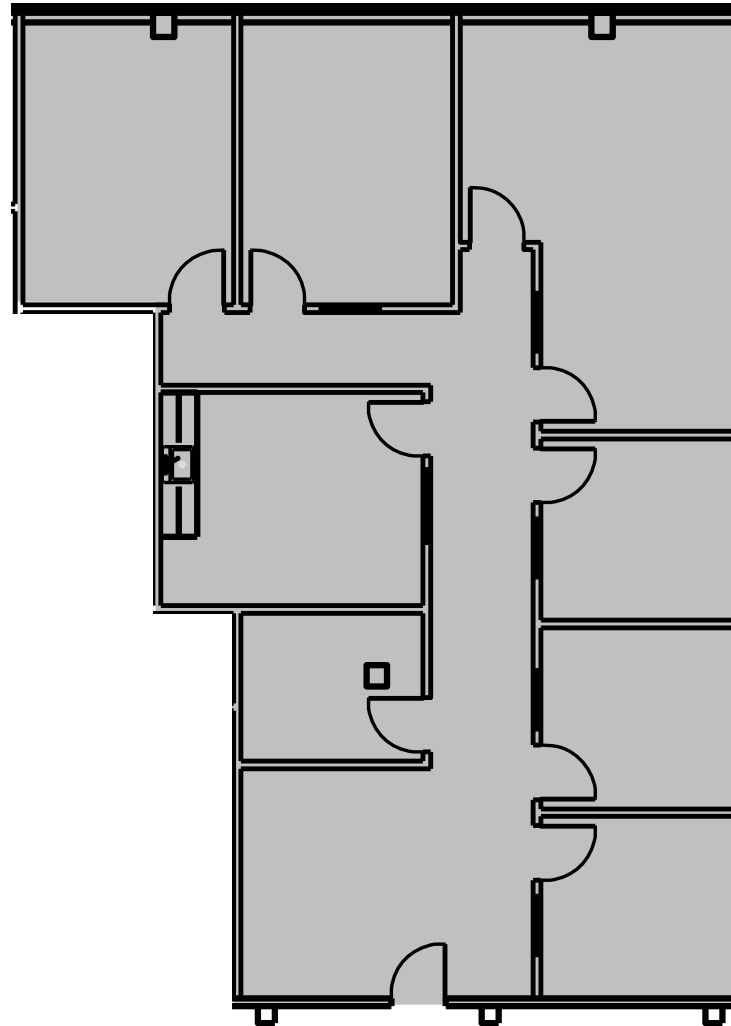
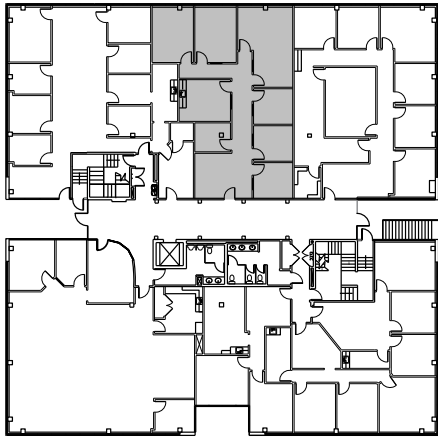

Building

5

Matt Frizzell

E matt.frizzell@cushwake.com

T +1 512 814 3404

Tom Rhea

E tom.rhea@cushwake.com

T +1 512 814 3416

AustinOaks

Suite 114
First floor
2,128 sf

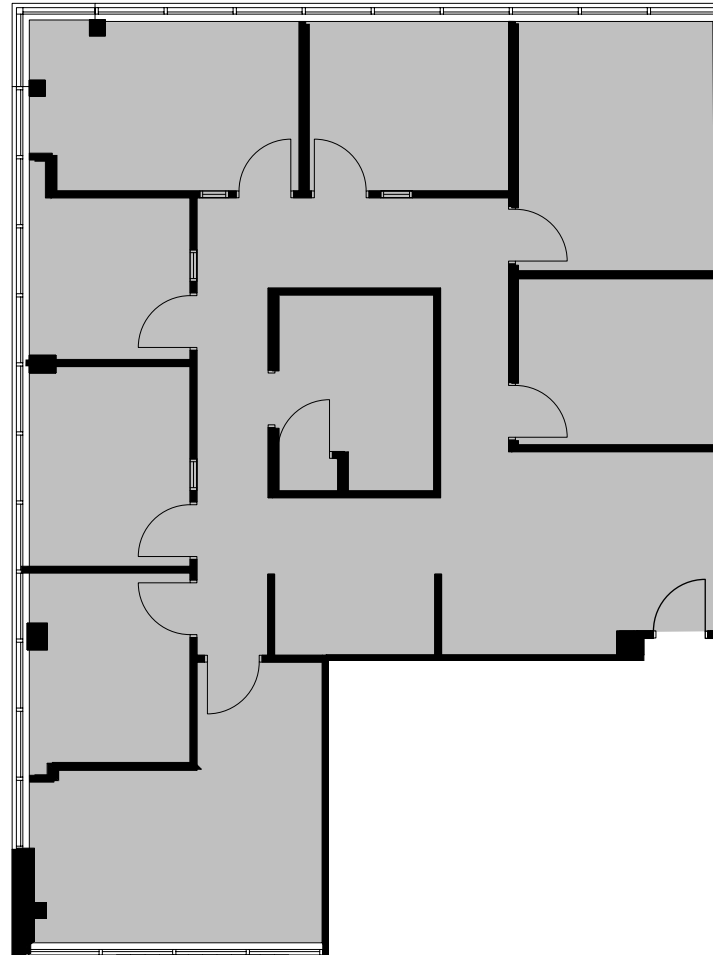
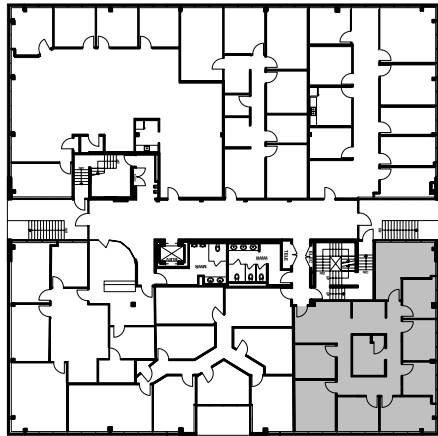

Building

4

Matt Frizzell

E matt.frizzell@cushwake.com

T +1 512 814 3404

Tom Rhea

E tom.rhea@cushwake.com

T +1 512 814 3416

AustinOaks

Suite 250
Second floor
2,135 sf

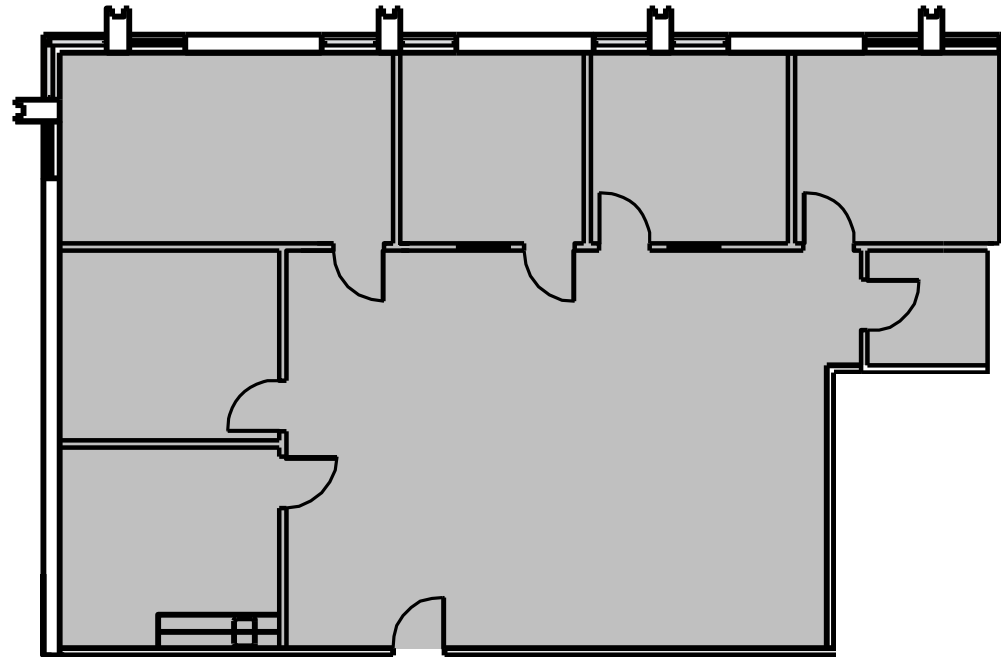
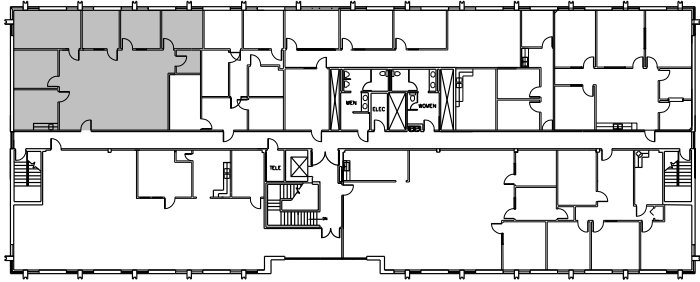

Matt Frizzell
E matt.frizzell@cushwake.com
T +1 512 814 3404

Tom Rhea
E tom.rhea@cushwake.com
T +1 512 814 3416

AustinOaks

Suite 151
First floor
2,215 sf

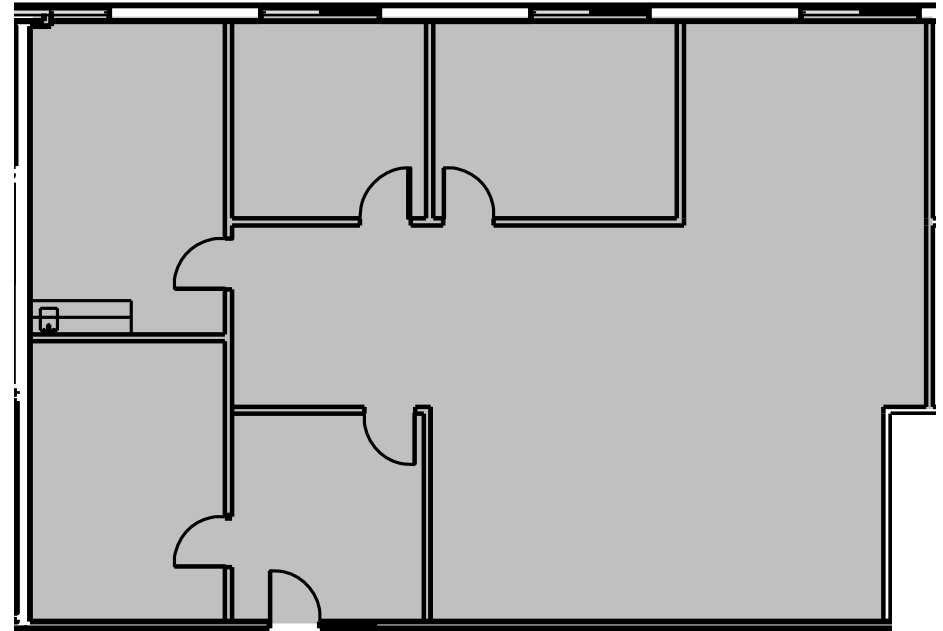
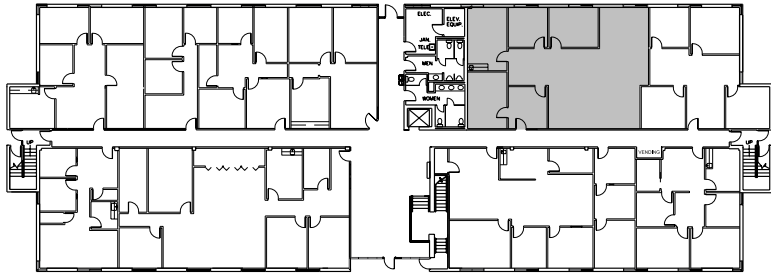

Matt Frizzell

E matt.frizzell@cushwake.com

T +1 512 814 3404

Tom Rhea

E tom.rhea@cushwake.com

T +1 512 814 3416

AustinOaks

Suite 205
Second floor
2,223 sf

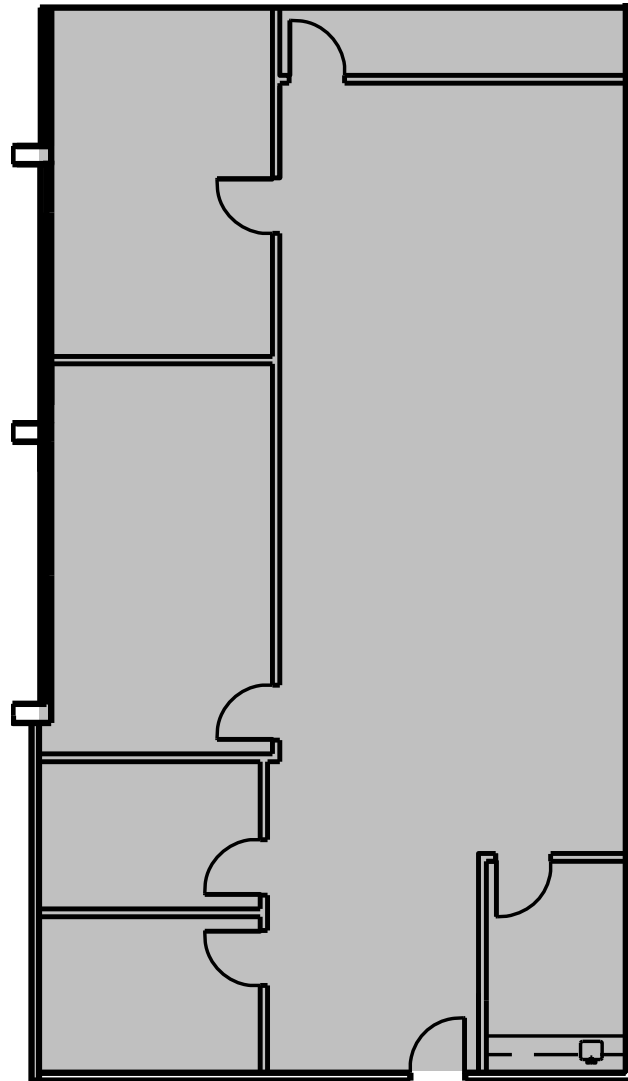
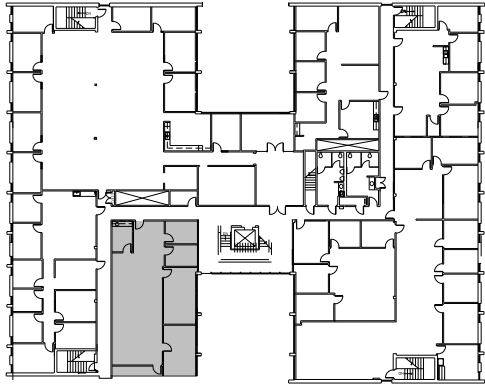

Matt Frizzell

E matt.frizzell@cushwake.com

T +1 512 814 3404

Tom Rhea

E tom.rhea@cushwake.com

T +1 512 814 3416

AustinOaks

Suite G10
Ground floor
2,375 sf

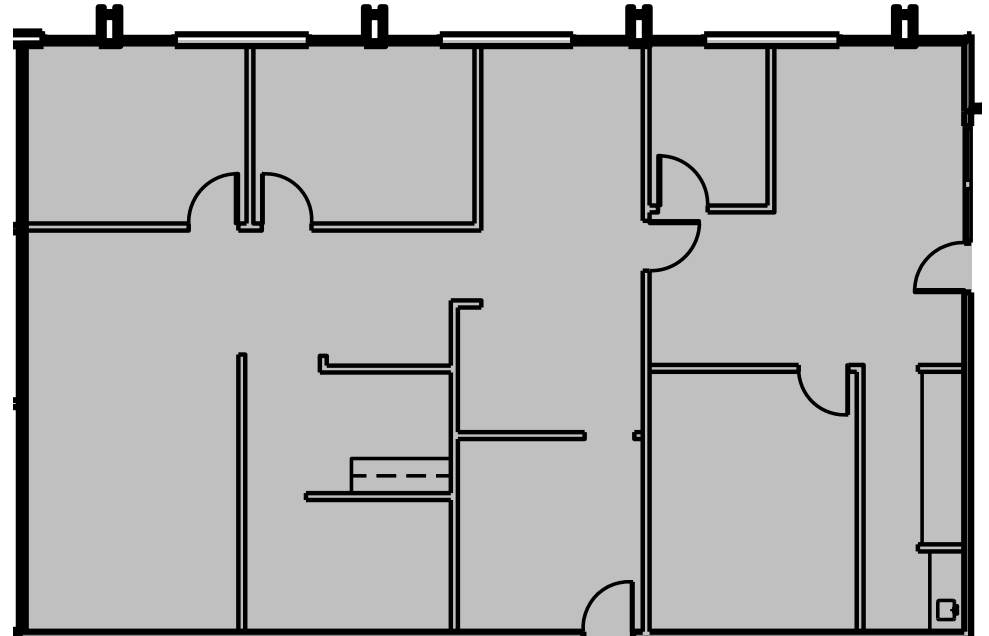
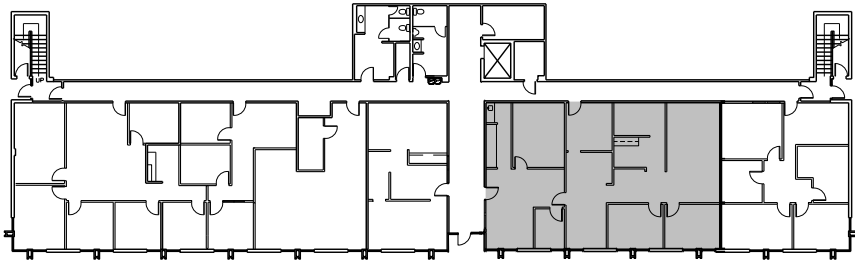

Matt Frizzell
E matt.frizzell@cushwake.com
T +1 512 814 3404

Tom Rhea
E tom.rhea@cushwake.com
T +1 512 814 3416

AustinOaks

Suite 215
Second floor
2,449 sf

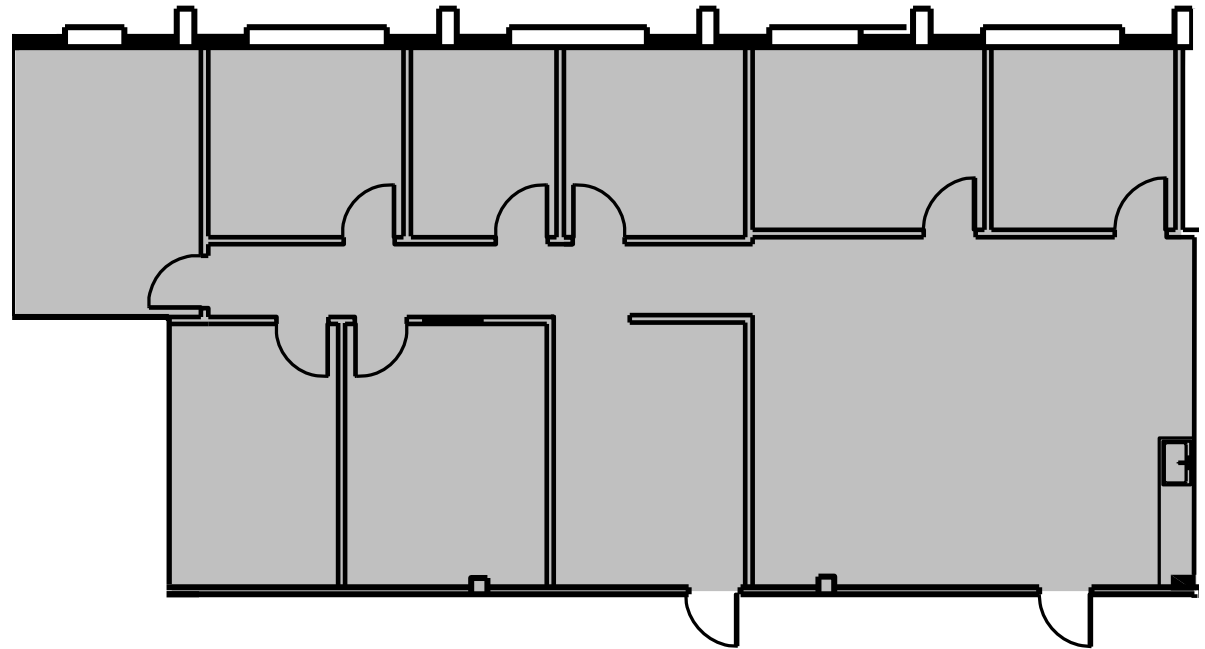
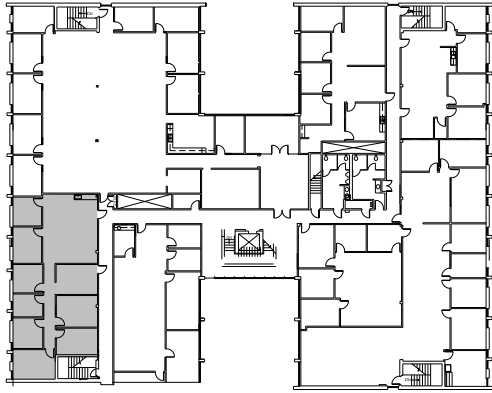

Matt Frizzell
E matt.frizzell@cushwake.com
T +1 512 814 3404

Tom Rhea
E tom.rhea@cushwake.com
T +1 512 814 3416

AustinOaks

Suite 201
Second floor
2,496 sf

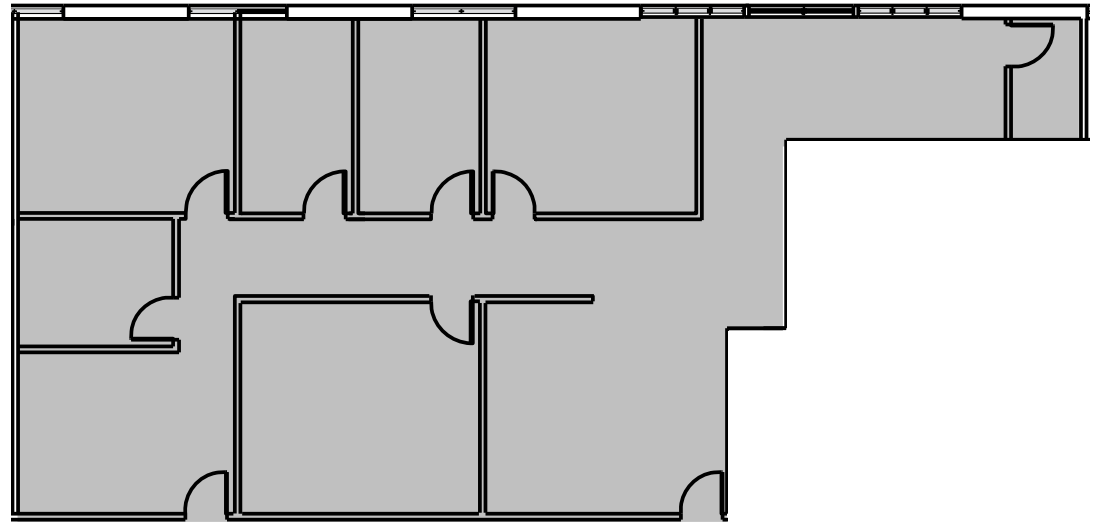
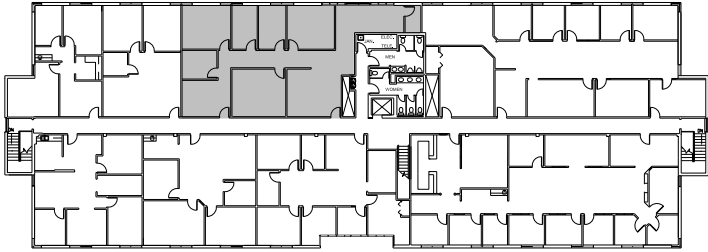

Matt Frizzell

E matt.frizzell@cushwake.com

T +1 512 814 3404

Tom Rhea

E tom.rhea@cushwake.com

T +1 512 814 3416

AustinOaks

Suite 210
Second floor
2,546 sf

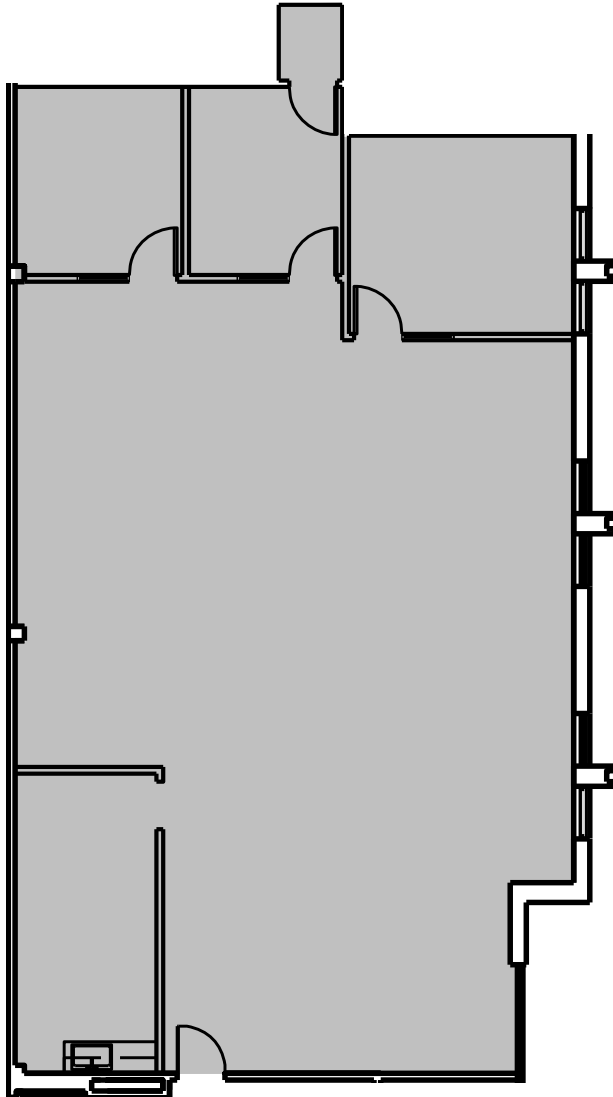
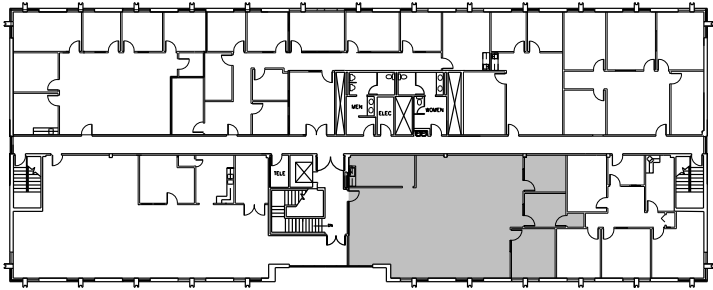

Matt Frizzell
E matt.frizzell@cushwake.com
T +1 512 814 3404

Tom Rhea
E tom.rhea@cushwake.com
T +1 512 814 3416

AustinOaks

Suite 110
First floor
2,634 sf

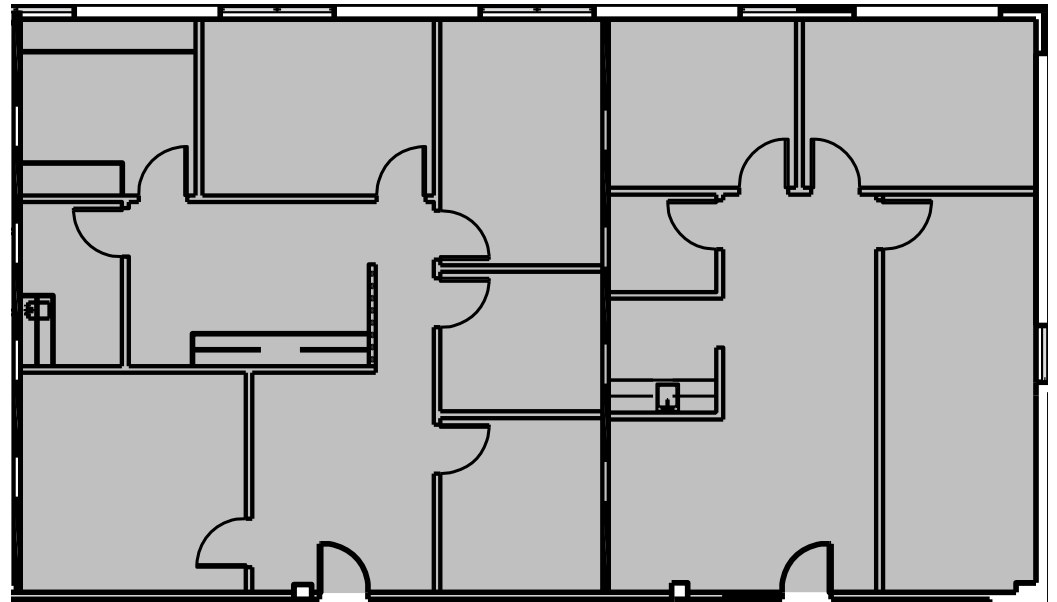
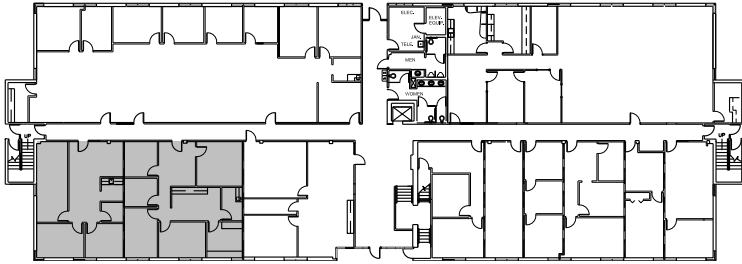

Building
10

Matt Frizzell
E matt.frizzell@cushwake.com
T +1 512 814 3404

Tom Rhea
E tom.rhea@cushwake.com
T +1 512 814 3416

AustinOaks

Suite 150
First floor
2,669 sf

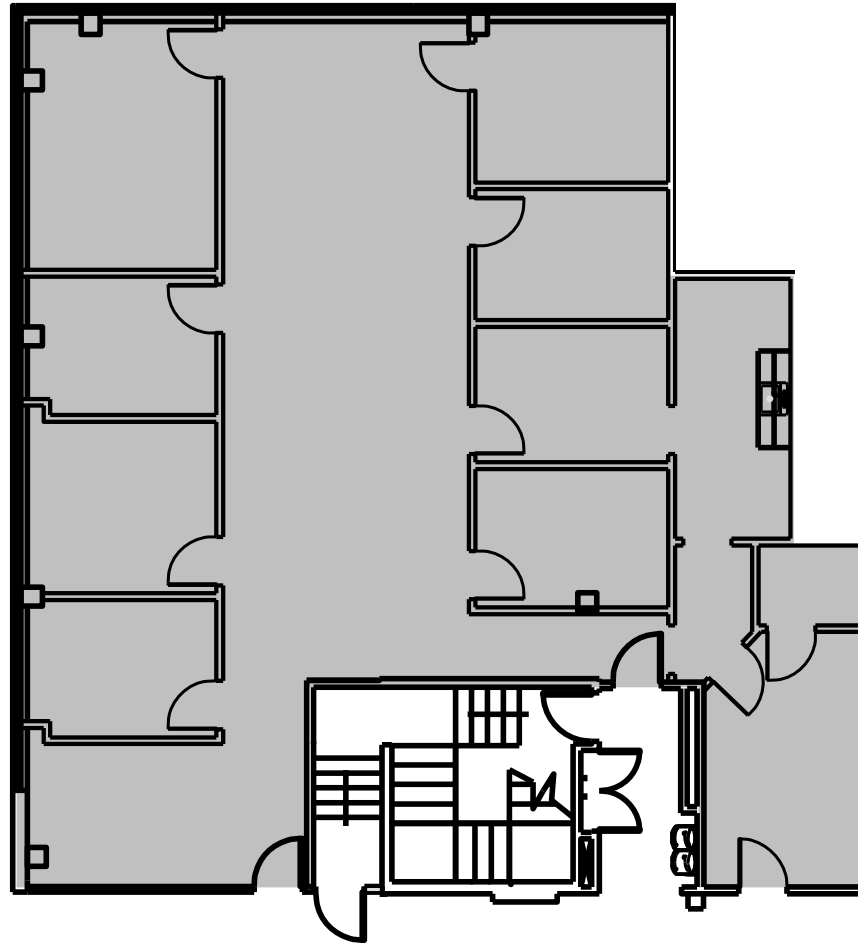
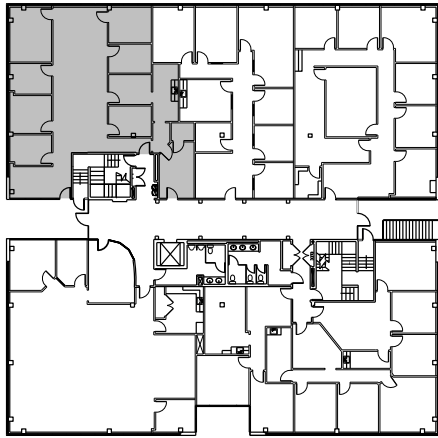

Building

5

Matt Frizzell

E matt.frizzell@cushwake.com

T +1 512 814 3404

Tom Rhea

E tom.rhea@cushwake.com

T +1 512 814 3416

AustinOaks

Suite 151
First floor
3,018 sf

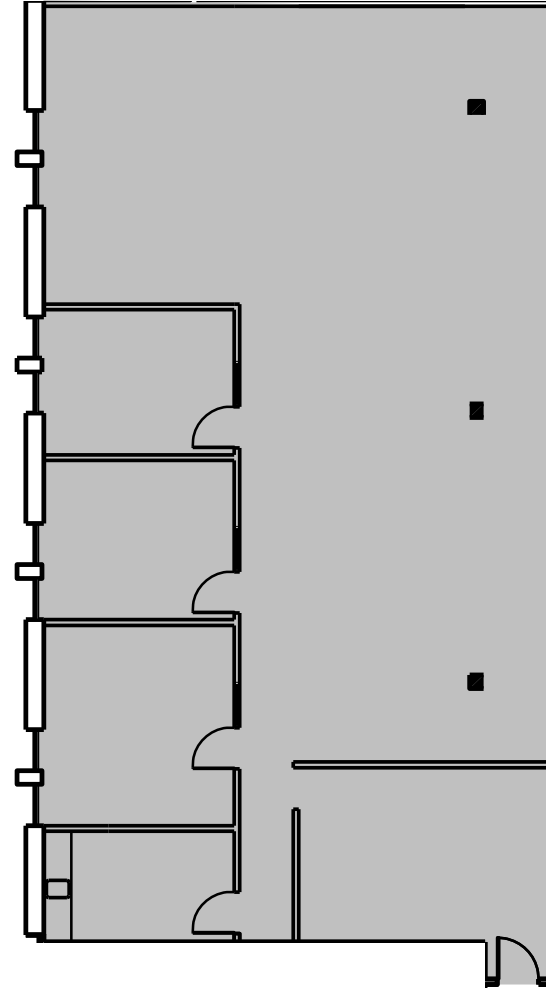
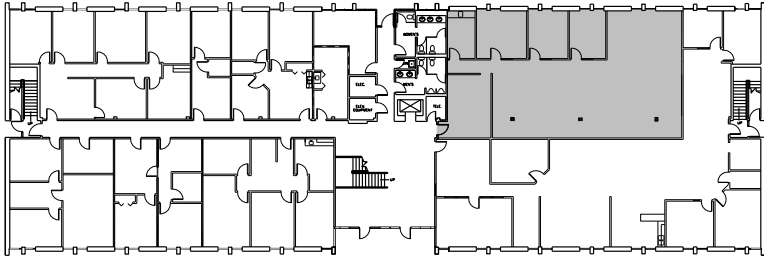

Matt Frizzell

E matt.frizzell@cushwake.com

T +1 512 814 3404

Tom Rhea

E tom.rhea@cushwake.com

T +1 512 814 3416

AustinOaks

Suite 160
First floor
3,216 sf

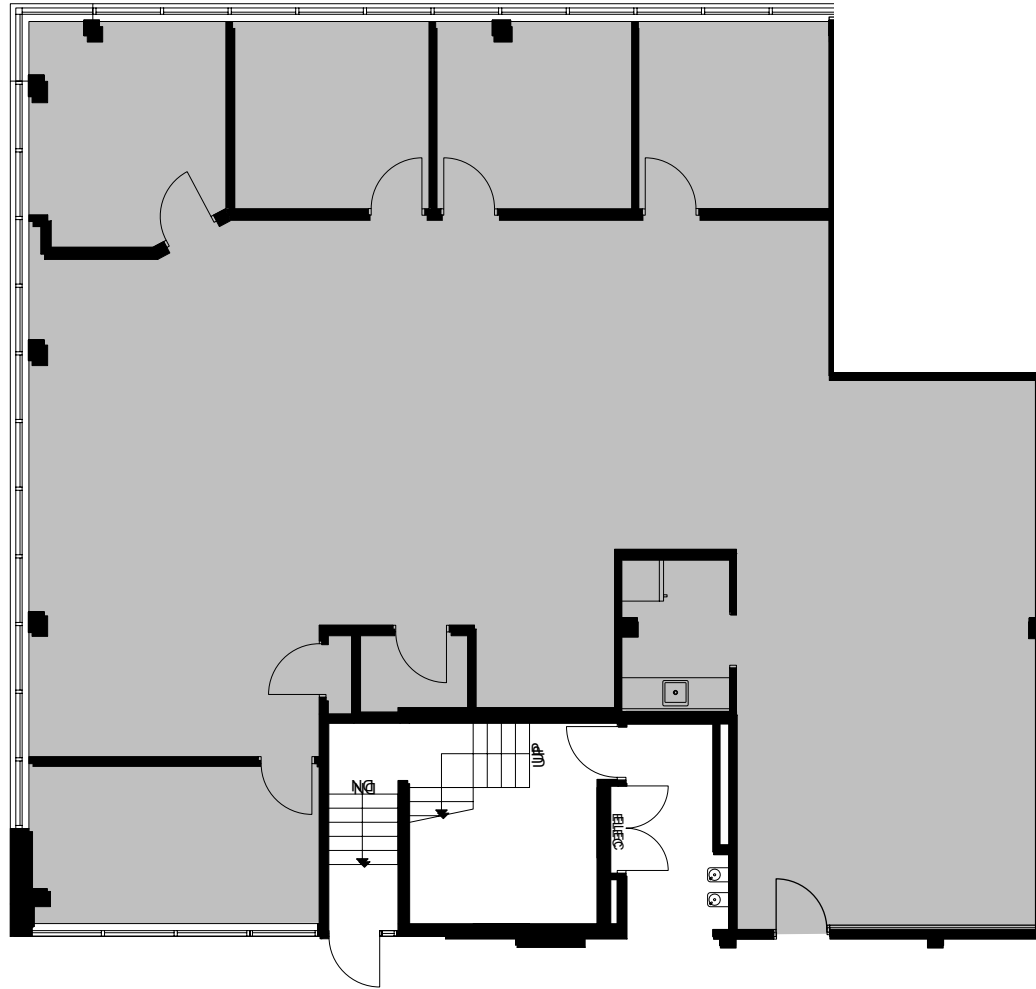
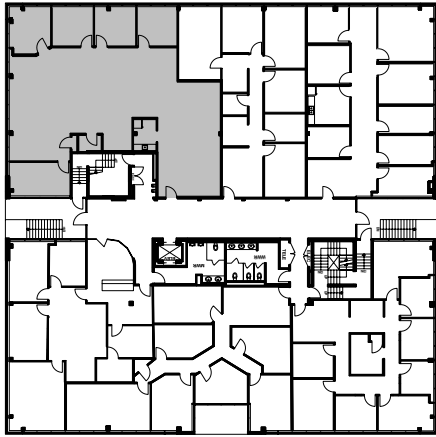

Building

4

Matt Frizzell

E matt.frizzell@cushwake.com

T +1 512 814 3404

Tom Rhea

E tom.rhea@cushwake.com

T +1 512 814 3416

AustinOaks

Suite 165
First floor
3,325 sf

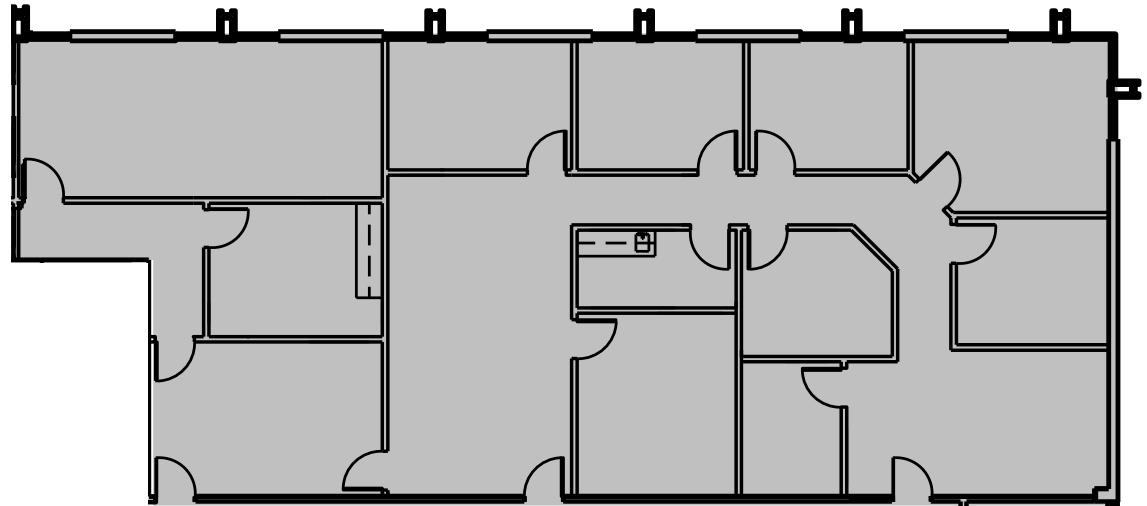
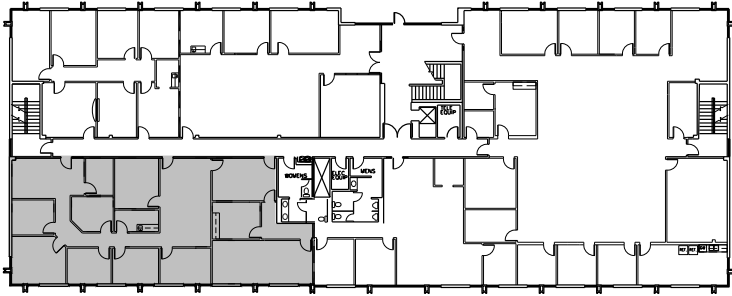

Matt Frizzell

E matt.frizzell@cushwake.com

T +1 512 814 3404

Tom Rhea

E tom.rhea@cushwake.com

T +1 512 814 3416

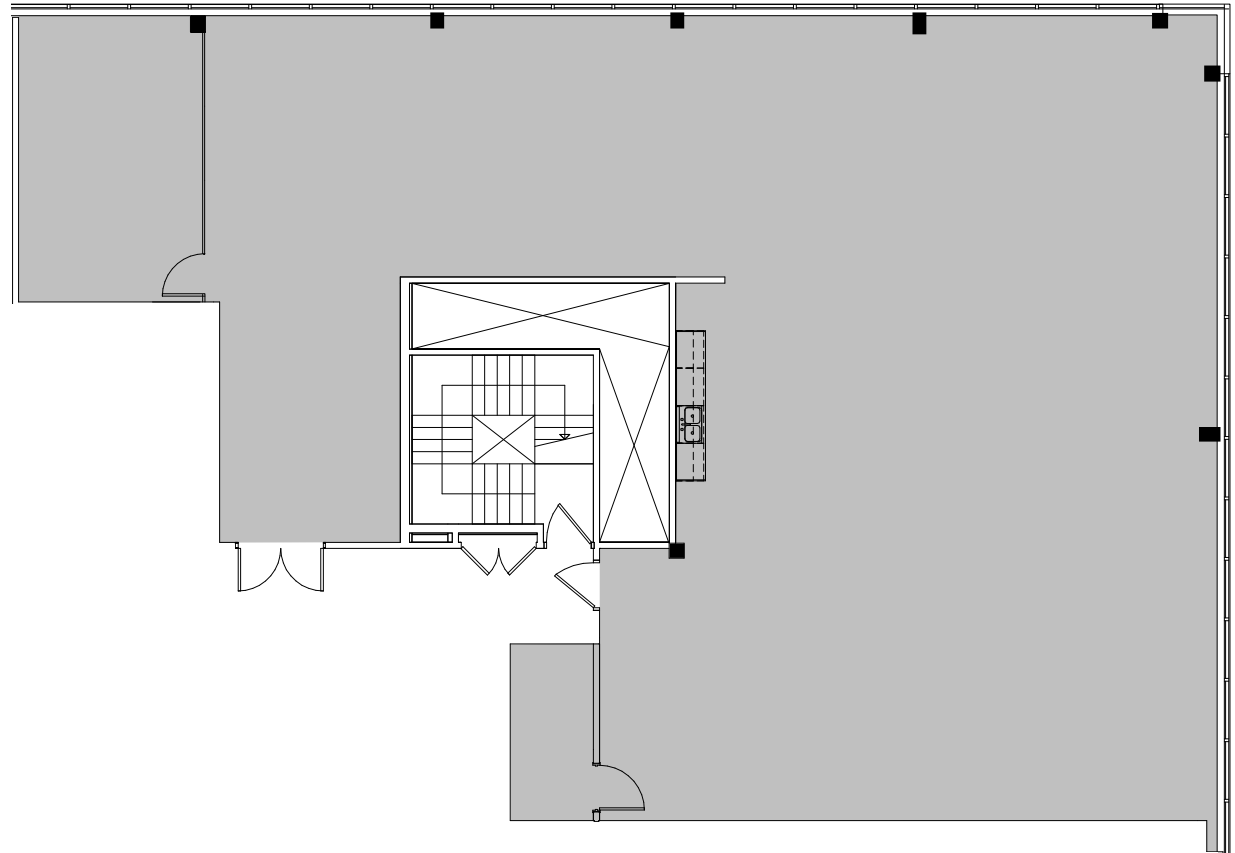
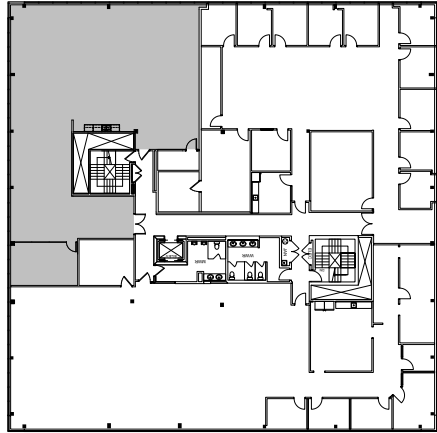

Matt Frizzell

E matt.frizzell@cushwake.com

T +1 512 814 3404

Tom Rhea

E tom.rhea@cushwake.com

T +1 512 814 3416

AustinOaks

Suite 200
Second floor
9,254 sf

Avail. in 90 days

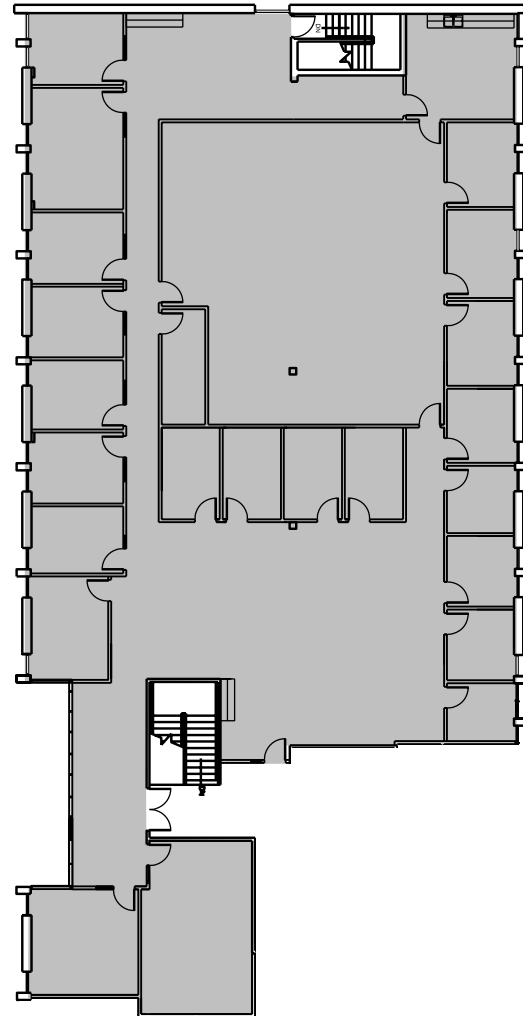
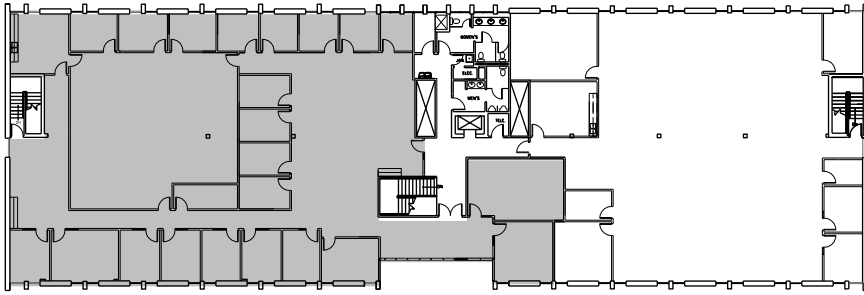

Building

2

Matt Frizzell

E matt.frizzell@cushwake.com

T +1 512 814 3404

Tom Rhea

E tom.rhea@cushwake.com

T +1 512 814 3416