

Property Owner

Name: CARROLL COUNTY AUTO CENTER LLC

Mailing Address: 303 N WALNUT #2
HARRISON, AR 72601

Type: (CI) Comm. Impr.

Over 65 Freeze: No

Tax Dist: (27B) BERRYVILLE CITY

Size (Acres): 6.790

Extended Legal: PT SW NE;PT SE NE 4.89 AC;1.94 AC

Property Information

Physical Address: 1004 MAIN ST S

Subdivision: 32-20-24 BERRYVILLE OUTLOTS

Block / Lot: -- / --

S-T-R: 32-20-24

Market and Assessed Values:

	Estimated Market Value	Full Assessed (20% Mkt Value)	Taxable Value
Land:	\$161,850	\$32,370	\$32,370
Building:	390400	78080	78080
Total:	\$552,250	\$110,450	\$110,450

Taxes:

Estimated Taxes:	\$6,075
Homestead Credit:	\$0

Note: Tax amounts are estimates only. Contact the county tax collector for exact amounts.

Land:

Land Use	Size	Units
	6.790	Acres

Special Assessments:

Assessment	Tax Amount
Solid Waste 17	\$18.00
Totals:	\$18.00

Deed Transfers:

Date	Book	Page	Deed Type	Stamps	Est. Sale	Grantee	Code	Type
5/22/2018	2018	1328	Quit Claim			CARROLL COUNTY AUTO CENTER LLC		Improved
11/23/2015	2015	2825	CorrDeed			CARROLL COUNTY AUTO CENTER LLC		
7/23/2013	2013	1151	Warr. Deed			CARROLL COUNTY AUTO CENTER LLC		
8/31/2006	162	108-110	Easement			CCC TO CITY OF B -VILLE		
8/31/2006	162	105-107	Easement			CCC TO CITY OF B -VILLE		

Not a Legal Document.
Subject to terms and conditions.

www.datascoutpro.com

Date	Parcel	Area	Type	Acres	Value	Description	Status	Notes
11/4/2005	159	890-891	Easement			CCC INC TO ENTERGY		
4/25/2005	158	236	Easement			AR W GAS TO CARROLL CO CHRYSLER		
4/25/2005	158	234	Easement			AR W GAS TO CARROLL CO CHRYSLER		
5/15/2000	149	117-18	Warr. Deed	1023.00	\$310,000	RAMSEY TO CARROLL CO CRY	Valid	Improved
12/13/1999	148	360-361	Warr. Deed	379.50	\$115,000	TAVAS TO CARROLL CTY CHRYS	Valid	
3/18/1993	136	391		0.00	\$0	QCD MYATT TO RAMSEY		
6/1/1990	131	56		83.60	\$38,000	MONCATA-MITCHELL TO RAMSEY	Unval.	
6/1/1990	131	54		33.00	\$15,000	COXEY TO RAMSEY	Unval.	
12/6/1989	130	2		0.00	\$0	SMITH TRST TO MONCATA-MITCHELL		
12/6/1989	130	1		0.00	\$0	MONCATA TO SMITH TRST		
9/9/1988	127	295		0.00	\$0	BILLIE 1/2 INT		
4/1/1988	126	230		198.00	\$90,000	FR WELLACE	Unval.	
10/20/1987	125	353-356	PT	0.00	\$0			
5/13/1987	126	228/29		66.30	\$60,273	FR 1ST NAT BANK TO SMITH	Unval.	
5/13/1987	126	226/27		63.80	\$58,000	EUREKA LOG HOMES, INC	Unval.	
2/23/1987	123	540-41	PT	0.00	\$0	ESCROW		
6/9/1986	122	298	PT	0.00	\$165,000	FRPM TAVAS		
6/25/1984	126	225		63.80	\$58,000	FR BV LIQUOR	Unval.	
1/1/1977	103	362-63	PT	0.00	\$0			

Details for Commercial Card 1:

Business Name(s): YOUTHBRIDGE

Number of Units:

Site Work: Fill; Prep;

Foundation: Concrete

Floor Struct: Elevated Slab

Struct. Frame: Rigid.Fr

Total Floor Area: 13540

Floor Cover: None

Ceilings: None

Interior Finish: None

Insulation: N/A

Not a Legal Document.
Subject to terms and conditions.

www.datascoutpro.com

Exterior Walls: DryvTile, PreF.Mtl
Ext. Wall Load: NonLoadB
Roof Struct.: Steel.JS
Roof Cover: RollRoof

Appliances: None
Plumbing: Lavatory
Electric: Avg.B
Misc: 00



DataScout, LLC

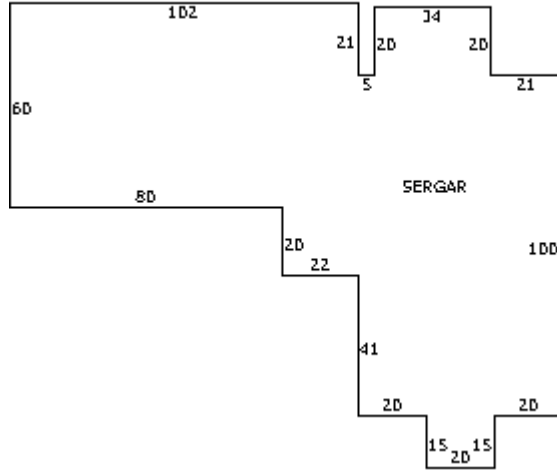

Building: 1

Age/YC	Condition	Effective Age	Stories	Grade
1995	Average	16	1	S3
Avg. Floor Area: 13540 Avg. Perimeter: 636 No. Floors: 1 Avg. Floor Hgt: 16		Common Wall: Total Floor Area: 13540 Total Height: 20 Unit Multiplier:		
Occupancy Primary Garages - Service (70%) Secondary Office Buildings - Comm. (30%)		Heating/Cooling H/A-NZ (30%) Suspended Heaters (70%)	Sprinkler N/A N/A	

Outbuildings and Yard Improvements:

Item	Type	Size/Dim	Unit Multi.	Quality	Age
Paving	ASPH	33000			
Paving	CONC3R	1020			
Lighting	MVAPFX	1			
Signs, Plastic Illum.	DFACEF	72			
Signs, Plastic Illum.	SFACEF	45			
Sign Posts or Poles		12x20			
Lighting	LGTP	20			
Fence, Chain Link	#9WIRE	6x120			
Multi-Purpose	SUBF				
Canopies	WOOD	25x62			
Canopies	METAL	23x42			

Map: