

BUSINESS PARK SPACE AVAILABLE
ADJACENT TO PAINE FIELD AIRPORT

PAINE FIELD

BUSINESS PARK

2615 WEST CASINO ROAD
EVERETT, WASHINGTON 98204



BRODERICK
• GROUP •

CONNOR GILCHRIST
425.274.4286
gilchrist@broderickgroup.com

RAWLEY HOLMBERG
425.274.4284
holmberg@broderickgroup.com

OWNED AND MANAGED BY:

Schnitzer
PROPERTIES

PAINE FIELD

BUSINESS PARK

2615 WEST CASINO ROAD
EVERETT, WASHINGTON 98204

PROPERTY FEATURES

- High profile space catering to service companies, small businesses, sales & distribution centers
- Grade level loading
- Warehouse ceiling height: 13' to bottom of joists – 15' to bottom of roof
- Convenient South Everett location
- Across the street from Boeing 777 & 787 plant
- Direct access to SR-526 & I-5
- Restaurants and shopping center nearby

SITE PLAN



SUITE	TOTAL SF	OFFICE SF	WAREHOUSE SF	AVAILABILITY	BASE RENT	NNN	GROSS RENT
<u>6E</u>	1,547 RSF	138 RSF	1,401 RSF	6/1/2024 Potentially available sooner	\$2,166	\$535	\$2,701



CONNOR GILCHRIST
425.274.4286
gilchrist@broderickgroup.com

RAWLEY HOLMBERG
425.274.4284
holmberg@broderickgroup.com

OWNED AND MANAGED BY:



PAINE FIELD

BUSINESS PARK

2615 WEST CASINO ROAD
EVERETT, WASHINGTON 98204



BRODERICK
• GROUP •

CONNOR GILCHRIST
425.274.4286
gilchrist@broderickgroup.com

RAWLEY HOLMBERG
425.274.4284
holmberg@broderickgroup.com

OWNED AND MANAGED BY:

Schnitzer
PROPERTIES

PAINE FIELD

BUSINESS PARK

2615 WEST CASINO ROAD
EVERETT, WASHINGTON 98204

PUGET SOUND

PAINE FIELD BUSINESS PARK I



- | | | | | | |
|------------------------------|-----------------------------|-------------------------|-------------------------------------|----------------------------|--------------------------|
| 1 Happy Tummy Grill | 7 IHOP | 13 Panera Bread | 19 UPS | 25 Michaels | 31 Taco Bell |
| 2 Goodwill | 8 FedEx | 14 Starbucks | 20 Arby's | 26 Walmart | 32 Memo's Mexican |
| 3 USPS | 9 Outback Steakhouse | 15 Target | 21 T.J. Maxx | 27 Everett Mall | 33 Popeye's |
| 4 Fred Meyer | 10 Office Depot | 16 V Star Buffet | 22 Best Buy | 28 LA Fitness | 34 Walgreens |
| 5 Public Storage | 11 BECU | 17 Trader Joe's | 23 Petco | 29 Wells Fargo Bank | 35 Albertson's |
| 6 Buzz Inn Steakhouse | 12 McDonald's | 18 Applebee's | 24 Kyoto Japanese Steakhouse | 30 Ross | 36 Dairy Queen |

BRODERICK
GROUP

CONNOR GILCHRIST
425.274.4286
gilchrist@broderickgroup.com

RAWLEY HOLMBERG
425.274.4284
holmberg@broderickgroup.com

OWNED AND MANAGED BY:

Schnitzer
PROPERTIES

PAINE FIELD

BUSINESS PARK

2615 WEST CASINO ROAD
EVERETT, WASHINGTON 98204

SUITE 6E

AVAILABLE 6/1/2024

POTENTIALLY AVAILABLE SOONER

TOTAL SF: 1,547 RSF

OFFICE SF: 128 RSF

WAREHOUSE SF: 1,401 RSF

BASE RENT: \$2,166

NNN: \$535

GROSS RENT: \$2,701

The information contained herein has been given to us by the owner or sources that we deem reliable. We have no reason to doubt its accuracy, but we do not guarantee it. Prospective tenants should carefully verify all information contained herein.

[↑ BACK TO AVAILABLE SPACE](#)

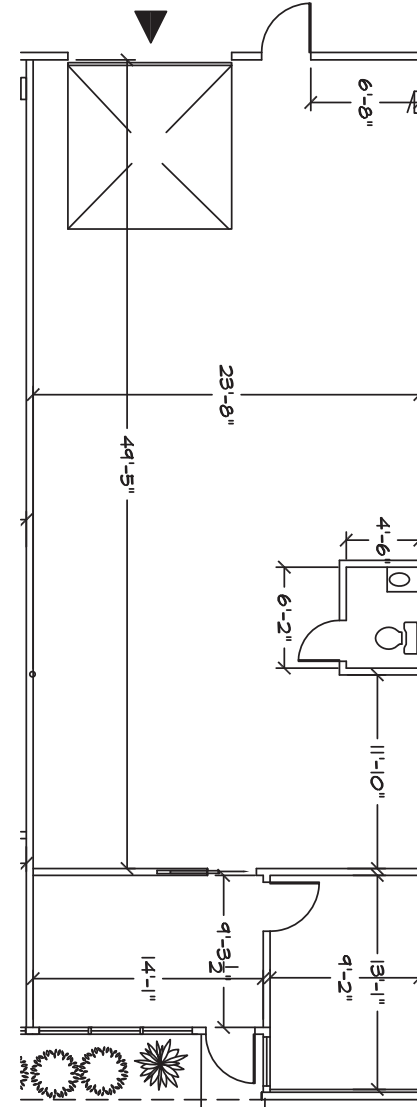

CONNOR GILCHRIST
425.274.4286
gilchrist@broderickgroup.com

RAWLEY HOLMBERG
425.274.4284
holmberg@broderickgroup.com

OWNED AND MANAGED BY:

