

LANDMARK THEATRE FOR SALE

650 GEARY STREET

INVESTMENT OPPORTUNITY | THEATRE DISTRICT | SAN FRANCISCO

VIRTUAL TOUR AVAILABLE! CLICK HERE!



Exterior showcasing Moorish-inspired exotic revival style architecture and motifs.



CELEBRATING
95 Years

GARY WARD
415.321.7483 | gw@brsf.co | DRE #01208708

JEREMY BLATTEIS
415.321.7493 | jfb@brsf.co | DRE #01460566

650 GEARY STREET

SAN FRANCISCO, CA 94102 | THEATRE DISTRICT

INVESTMENT OPPORTUNITY

INCREDIBLE OPPORTUNITY TO PURCHASE THE HISTORIC ALCAZAR THEATRE

Blatteis Realty is pleased to offer Investors and Developers the incredible opportunity to purchase the Alcazar Theatre ("The Property"), located at 650 Geary Street near San Francisco's Theatre District and within walking distance to Union Square. The building would be ideal for either an investor, developer, or for an owner/user looking to acquire an asset in Downtown San Francisco that would give them full building identity.

This is an incredibly rare find, and a thrilling opportunity to purchase a property with such a rich and storied San Francisco history. This Property is currently a functioning 516-seat theatre and contains over 31,000 rentable square feet. The building is 100% available which allows investors an incredible opportunity to take advantage of the robust San Francisco real estate market.

±31,000 SF

SIZE

PLEASE CALL

PRICE

1917

BUILT

1993

RENOVATED

Historical Description



The Alcazar Theatre is a 516-seat theatre located at 650 Geary Street, San Francisco, California. The venue is host to many touring productions of Broadway and Off Broadway plays, as well as variety, cabaret, comedians, and other theatrical events of varying quality.

Built in 1917 as a Shriner's Temple, the building was designed in Exotic Revival style, looking much like an Islamic temple, by architect T. Patterson Ross. After the Alcazar Theatre at 260 O'Farrell Street closed on December 31, 1961 and then demolished, this former temple on Geary Street became a legitimate theatre in 1976 and took on the name Alcazar. The structure was gutted in 1982, despite community efforts to save it, but reopened in 1993. Standing just west of Union Square, in the heart of the theatre district, the Alcazar has been renovated combining state of the art facilities with the architectural style of the past. The Alcazar Theatre was designated San Francisco Historical Landmark #195 in 1989.

Source
Wikipedia

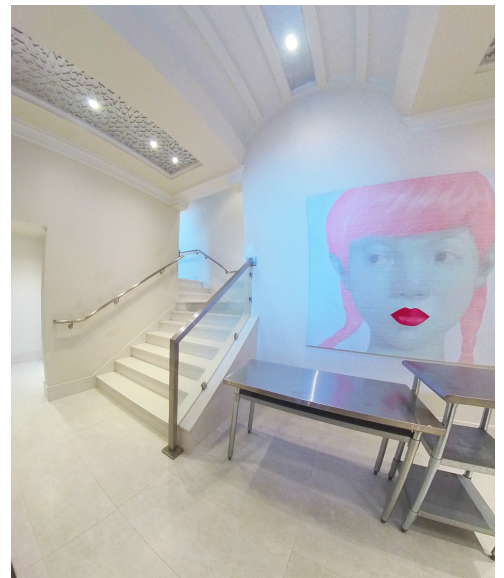

516-SEAT HISTORIC THEATRE

Modern interior offers Moorish-inspired motifs throughout building.



MAIN GROUND FLOOR ENTRANCE



RETAIL SPACE



THEATRE INTERIOR



MEZZANINE LOBBY



MEZZANINE LOBBY/THEATRE ENTRANCE



STAGE LEFT

BACKSTAGE AMENITIES

Featuring remodeled dressing rooms, lounge/meeting areas and office space.



PERFORMER DRESSING ROOMS



GALLERY/MEETING ROOM



PRIVATE LIBRARY



LOUNGE/MEETING AREA



CATERER'S KITCHEN



LOUNGE/MEETING AREAS

SPACIOUS OFFICES & LUXURY LIVING AMENITIES

Renovated office suites, multiple meeting/lounge areas and modern living space offers a comfortable environment for creative production staff, administration and artists-in-residence.



LOUNGE/MEETING AREA



HALLWAY/OFFICE AREA



OFFICE



BEDROOM



FULL KITCHEN & LOUNGE/MEETING AREA



PRIVATE BALCONY

Floor Plans

SIZE

±31,000 SF

This asset offers high ceilings, a beautiful historic facade, retail and office spaces, as well as dedicated parking.

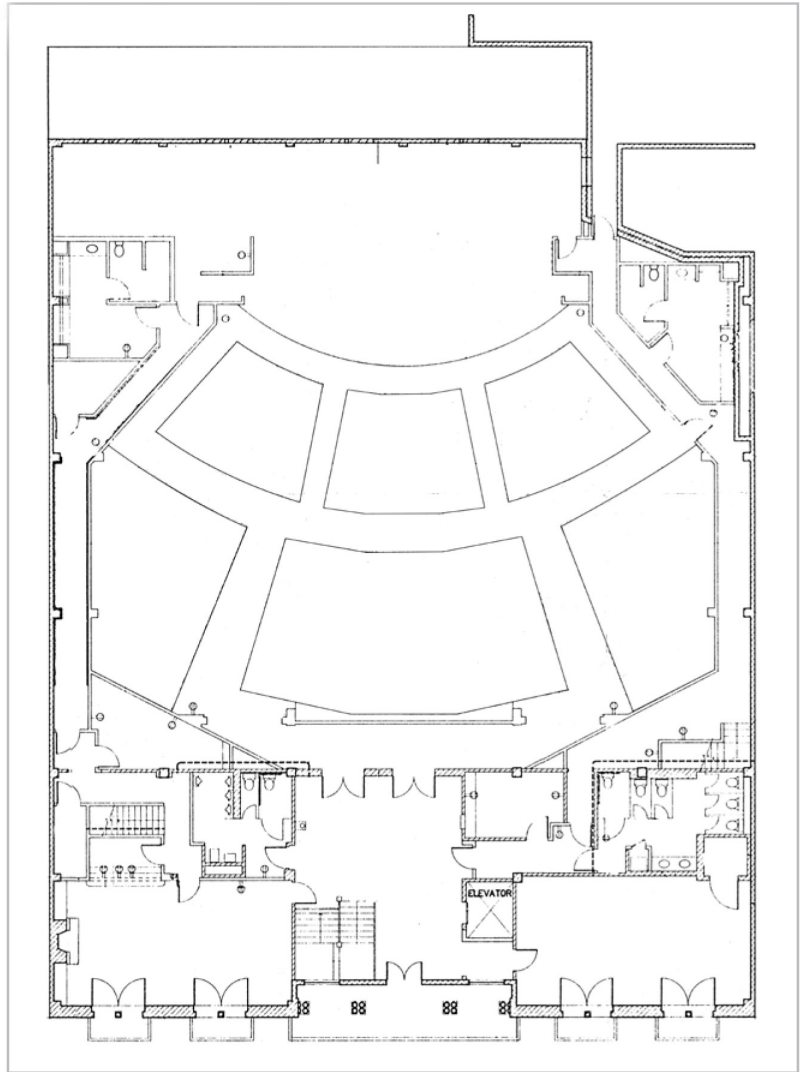

THEATRE

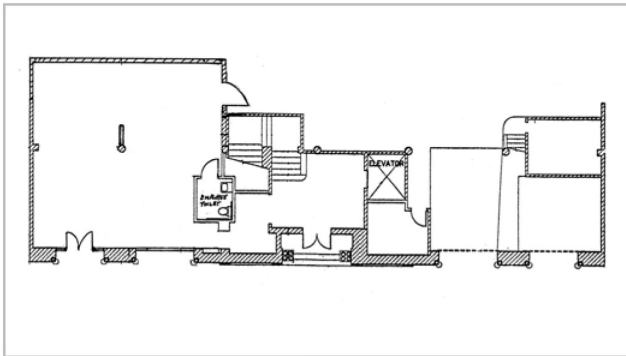

ENTRY WAY

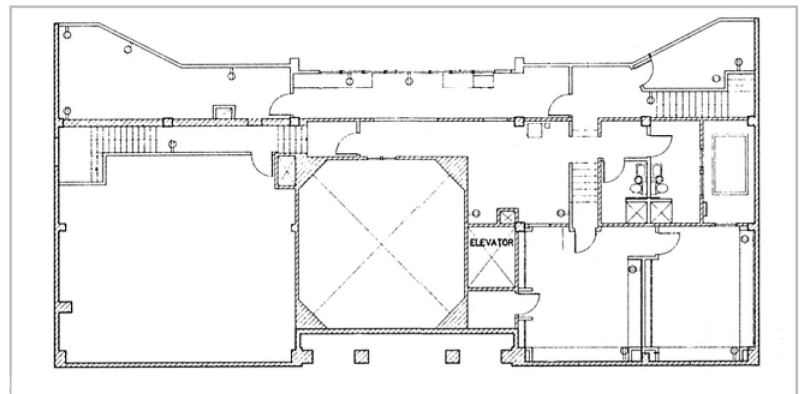

MEZZANINE

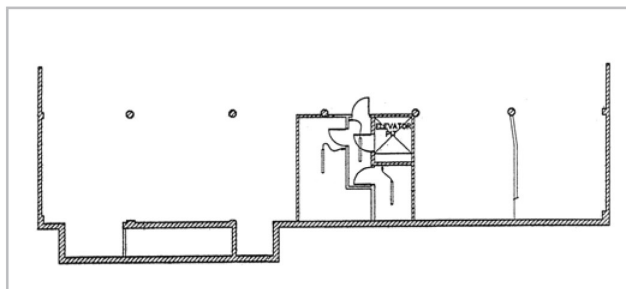

PARKING AREA

Map

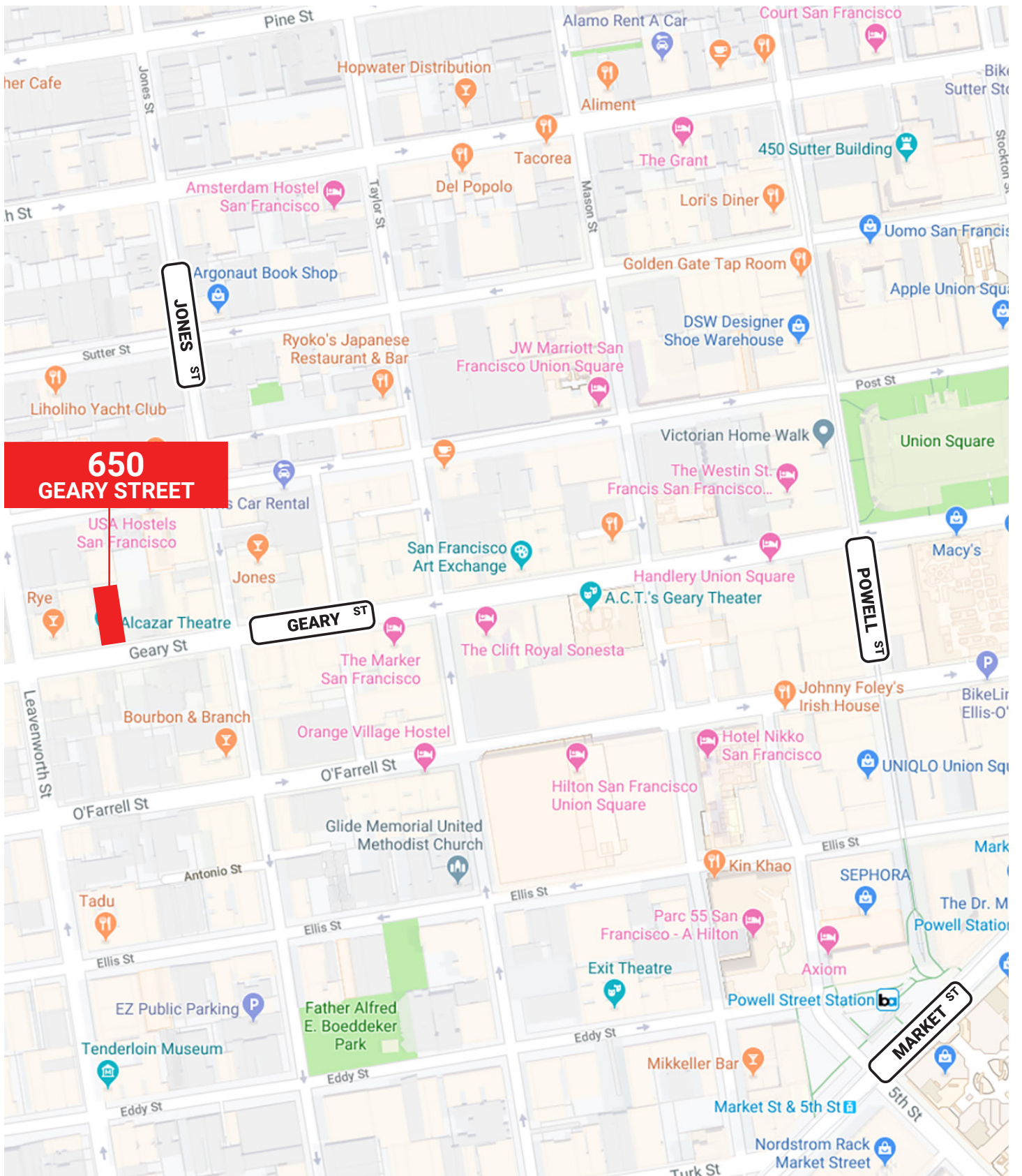

CONTACT

GARY WARD
415.321.7483
gw@brsf.co
DRE #01208708

JEREMY BLATTEIS
415.321.7493
jfb@brsf.co
DRE #01460566



CELEBRATING
95 Years

44 Montgomery Suite 1288, San Francisco, CA 94104 | t: 415.981.2844 | f: 415.981.4986 | info@brsf.co | DRE #01421282 | sftail.net

This statement with the information it contains, is given with the understanding that all negotiations relating to the purchase, renting or leasing of the property described above shall be conducted through this office. The above information, while not guaranteed, has been secured from sources believed to be reliable. We have not verified its accuracy and make no guarantee, warranty or representation regarding this information and it is published subject to the possibility of errors, omissions, changing of listing information including price, term, financing, or withdrawal without notice. We include projections, estimates, opinions, and/or assumptions, for example only, and they may not represent current or future performance of the property. You should consult your tax and legal advisors before to verify the validity of our estimates.