



FOR LEASE - 1<sup>ST</sup> & 2<sup>ND</sup> FLOORS

±3,516 SF RESTAURANT &  
±3,520 SF EVENT/OFFICE SPACE

324 NE 3<sup>RD</sup> AVE. | DELRAY BEACH, FL

New Development



PROPOSED RENDERING

DELIVERY Q2 2020

**NICOLE FONTAINE**

*Senior Director*

[NicoleFontaine@dkatz.com](mailto:NicoleFontaine@dkatz.com)

(561) 869-4350



## HIGHLIGHTS

- Delivery in Q2 2020
- Four-story building with a total of ±14,194 SF of interior space with bonus roof top deck, consisting of ±3,516 SF 1st floor restaurant space and 2nd floor ±3,250 SF (demisable) event/office space
- Palm Beach county's first automated parking garage with 52 spaces
- The distinctive architectural design and roof top ambience will add a contemporary icon to the Delray Beach skyline
- Located steps away from highly sought after Pineapple Grove, that includes 2 hotels totaling 275 rooms and 600+ residential dwellings
- Downtown Delray won the national award for "Most Fun Small Town in America"
- New artist streetscape planned for 3<sup>rd</sup> Avenue
- Approximately 11,585 employees in a 1 mile radius, 66,481 in a 3 mile radius and 158,781 in a 5 mile radius
- More than 5,995 households in a 1 mile radius, 34,212 in a 3 mile radius and 86,326 in a 5 mile radius

## DEMOGRAPHICS

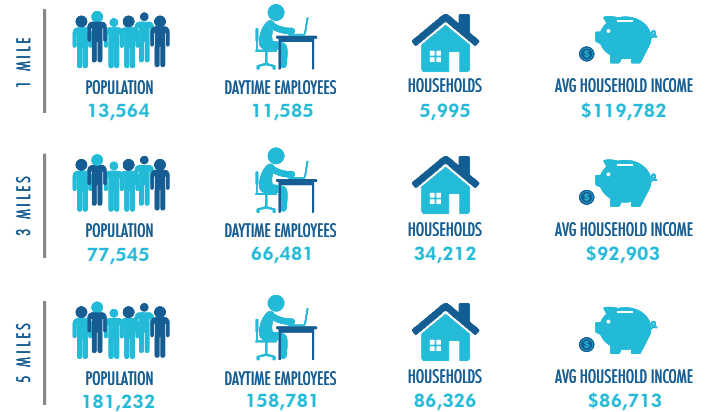

## MEET YOUR CUSTOMERS

WITHIN 3 MILES



TOTAL  
RETAIL SALES  
\$1.06B



SPENT ON DINING OUT &  
ALCOHOLIC BEVERAGES  
\$331.04M



SPENT ON APPAREL  
& SERVICES  
\$109.68M

# KATZ & ASSOCIATES

1<sup>ST</sup>  
FLOOR:  
RESTAURANT  
±3,516 SF

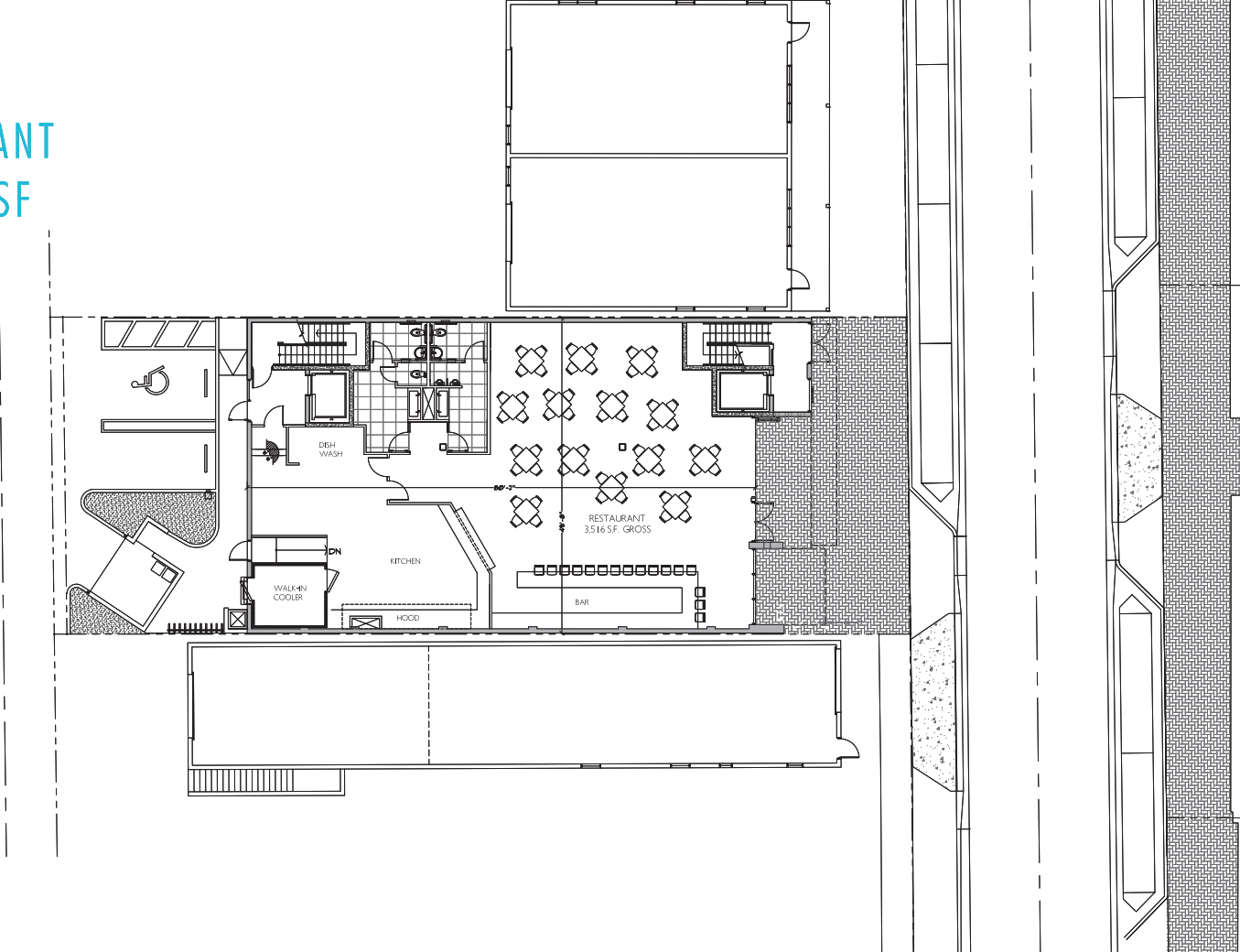

2<sup>ND</sup>  
FLOOR  
EVENT/  
OFFICE  
±3,520 SF

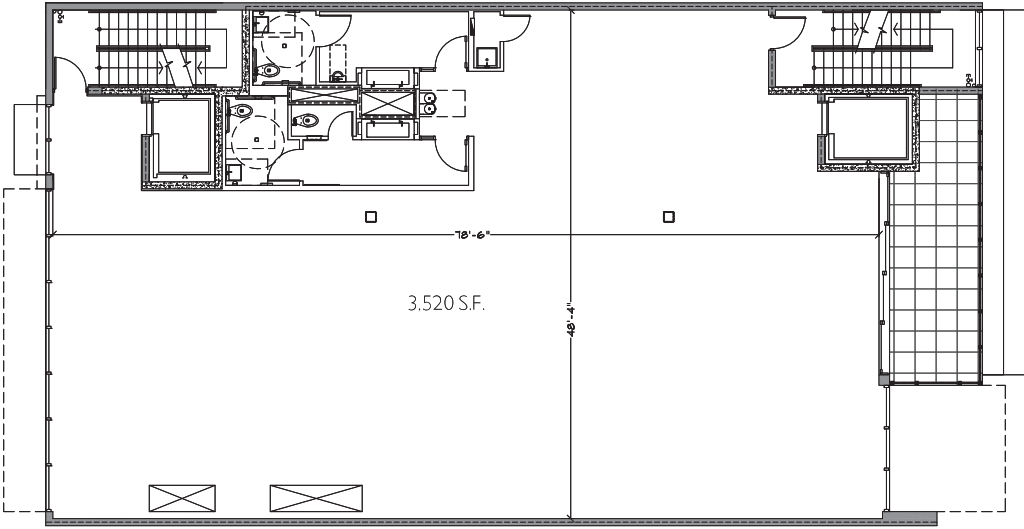



# KATZ & ASSOCIATES



BEDNER'S FARM FRESH MARKET



THE RAY HOTEL



ARTS WAREHOUSE



HYATT PLACE

## TRAFFIC COUNTS

- I-95 at Atlantic Avenue - 209,000 ADT
- Swinton Avenue at NW 3<sup>rd</sup> Street - 14,500 ADT
- 5<sup>th</sup> Avenue and 4<sup>th</sup> Avenue - 14,000 ADT
- Atlantic Avenue at 3<sup>rd</sup> Avenue - 25,000 ADT

## DRIVE TIMES

- 5 minutes to Interstate 95
- 30 minutes north or south to the next urban retail streetscape
- 20 minutes to Palm Beach International Airport

## IMMEDIATE MARKET DRIVERS

HOTEL/RESORTS (Total Rooms - 1,229):

 <b>141 ROOMS</b>	 <b>12 ROOMS</b>	 <b>154 ROOMS</b>	 <b>70 ROOMS</b>	 <b>131 ROOMS</b>
 <b>82 ROOMS</b>	 <b>28 ROOMS</b>	 <b>51 ROOMS</b>	 <b>134 ROOMS</b>	 <b>189 ROOMS</b>
 <b>122 ROOMS</b>	 <b>115 ROOMS</b>			

## EMPLOYEES:

- Approximately 11,200 employees in walking distance to downtown retail and restaurants

## ANNUAL VISITORS:

- Delray Beach welcomes approximately 600,000 visitors annually

## ARTS WAREHOUSE:

- ±15,000 SF art incubator, that gives an exciting opportunity for the community, entrepreneurs, visitors and artists to showcase their artwork, take art classes and workshops; special event space as well

**SITE | ADDITIONAL INFORMATION**

324 NE 3<sup>RD</sup> AVENUE  
DELRAY BEACH, FL





## AERIAL | CLOSE-UP

324 NE 3RD AVENUE  
DELRAY BEACH, FL